

2022

B&B
ITALIA **OUTDOOR**

The Outdoor Collection

The Outdoor Collection | 2022

Product inspiration

15 years of B&B Italia Outdoor Collection

The success of B&B Italia Outdoor can be measured by its consistency and results. With distinguishing features in its evolution, the collection celebrates 15 years of design and innovation work this year.

B&B Italia was the first company in its category to strive towards developing a range of outdoor furniture aiming to bring the intrinsic qualities of its indoor collections to outdoor designs, without compromising on product excellence.

Today, after 15 years, the strength of that decision is reflected not only in the variety of the offering, but also in the steady growth of sales success.

Values

For B&B Italia, quality means pushing forward and rewriting traditional design codes to create excellent products.

Research and technological innovation are conveyed through the continuous investigation to discover new materials and construction solutions. **Ergonomics and comfort** are expressed in new ways in each outdoor collection to make relaxation tangible without compromising on impeccable aesthetic. **Creativity** is another distinctive trait.

At times subtle, at times obvious, the ability to create the unthinkable is interpreted in different ways that embrace every style. The outdoor collections are capable of enhancing any interior, providing customers and interior decorators with such a choice in terms of range and features.

Sustainability

Being mindful of the environment is particularly relevant when it comes to outdoor living. That's why sustainability has been of intrinsic importance for B&B Italia outdoor since its very first collections.

Sustainability has been part of the company's philosophy for 15 years and, even when not made explicit, it is something that has been practised through the use of recycled and recyclable materials, associated with structures that can be easily disassembled.

These steps, and those that will come after, are making the circular economy a concrete reality for B&B Italia, as we move towards a new understanding of design and its industrial processes.

15 anni di B&B Italia Outdoor Collection

Una storia di successo si misura attraverso coerenza e risultati, fattori che contraddistinguono l'evoluzione della collezione outdoor di B&B Italia, che quest'anno celebra 15 anni di progetti e innovazioni.

B&B Italia è stata di fatto la prima azienda della sua categoria a perseguire con decisione l'idea di una linea di arredi outdoor con l'obiettivo di portare all'esterno le qualità intrinseche delle sue collezioni indoor, senza scendere a compromessi con l'eccellenza del prodotto.

Oggi, dopo 15 anni, la forza di tale scelta si rispecchia nella notorietà globale delle collezioni, nella varietà dell'offerta ma anche in un successo di vendite in costante crescita.

Valori

Per B&B Italia qualità significa spinta in avanti e riscrittura dei codici della tradizione per creare prodotti d'eccellenza.

Ricerca e innovazione tecnologica si esprimono attraverso la continua indagine alla scoperta di nuovi materiali e soluzioni costruttive.

Ergonomia e comfort trovano forme di espressione sempre nuove per rendere tangibile un relax che non rinuncia a un'estetica sempre impeccabile.

Non può mancare la **creatività**. A volte sussurrata, a volte palese, troviamo questa capacità di pensare l'impensabile in molte declinazioni che abbracciano ogni stile, offrendo a clienti e interior decorator una scelta unica nel suo genere per ampiezza e caratteristiche.

Sostenibilità

L'attenzione all'ambiente diventa particolarmente rilevante nella vita all'aria aperta. Per questo l'outdoor di B&B Italia ha messo al centro la sostenibilità fin dalle sue prime collezioni. Pensiero costante per 15 anni, anche quando non dichiarato esplicitamente è stato messo in pratica attraverso materiali riciclati e riciclabili, associati a strutture facilmente disassemblabili.

Grazie a questi passi e a quelli che seguiranno, l'economia circolare diventa reale e concreta per B&B Italia, nella direzione di una nuova concezione del design e dei suoi processi industriali.



The Outdoor Collection | 2022

Product inspiration

Product index

Indice prodotti

	Inspiration Specifications			Inspiration Specifications	
Awa Outdoor • Naoto Fukasawa	248	14	Kyra • B&B Italia CR&S	262	146
Ayana • Naoto Fukasawa	50	16	Link Outdoor • Jacob Wagner	220	148
Bay • Nipa Doshi & Jonathan Levien	170	26	Mirto Outdoor • Antonio Citterio	120	150
Borea • Piero Lissoni	22	34	Oh, it rains! • Philippe Starck	74	170
Butterfly • Patricia Urquiola	184	52	Overscale Flames Outdoor •		
Canasta '13 • Patricia Urquiola	198	66	Jean-Marie Massaud	252	174
Canasta • Patricia Urquiola	204	56	Pablo Outdoor • Vincent Van Duysen	4	176
Canasta tables • Patricia Urquiola	208	62	Papilio Shell Outdoor • Naoto Fukasawa	228	190
Charles Outdoor • Antonio Citterio	158	72	Piet • B&B Italia CR&S	264	192
Colosseo Outdoor • Naoto Fukasawa	244	78	Pushpam • Naoto Fukasawa	226	194
Cosmos Outdoor • Jeffrey Bernett	224	80	Ray Outdoor Fabric • Antonio Citterio	138	196
Crinoline • Patricia Urquiola	212	82	Ray Outdoor Natural • Antonio Citterio	146	202
Erica '19 • Antonio Citterio	106	90	Ribes • Antonio Citterio	86	210
Erica • Antonio Citterio	116	86	Spool Outdoor • Piero Lissoni	234	228
Fat-Fat Outdoor • Patricia Urquiola	246	98	Springtime • Jean-Marie Massaud	256	230
Fat-Sofa Outdoor • Patricia Urquiola	192	100	Titikaka • Naoto Fukasawa	250	232
Frank Outdoor • Antonio Citterio	258	104	Tobi-Ishi Outdoor •		
Ginepro • Antonio Citterio	164	106	Edward Barber & Jay Osgerby	218	234
Ginestra • Antonio Citterio	178	110	Tramae • unPIZZO	236	236
Gio • Antonio Citterio	148	114	Twist • B&B Italia CR&S	266	238
Hospes • B&B Italia CR&S	240	124	White Collection • Marcel Wanders	254	240
Husk Outdoor • Patricia Urquiola	230	126			
Hybrid • Antonio Citterio	62	132			
Kaleidos • B&B Italia CR&S	266	142	Fabrics		242
Karam • B&B Italia CR&S	260	144	Dedicated fabrics		252

Pablo Outdoor

Vincent Van Duysen

“My first collection for B&B Italia’s outdoor line develops the Pablo armchair features and adds layers of softness, and the tables are a link to my architectural world“.

Vincent Van Duysen

“Questa mia prima collezione per la linea outdoor di B&B Italia sviluppa nelle sedute le caratteristiche della poltrona Pablo aggiungendovi strati di morbidezza, e si lega al mio mondo architettonico nella parte dei tavoli”.

Vincent Van Duysen





These pages:

Pablo Outdoor, sofas • PBL210
Pablo Outdoor, armchairs • PBL80
Pablo Outdoor, ottoman • PBL75P
Pablo Outdoor, small tables • TPB130 • TPB55

In queste pagine:

Pablo Outdoor, divani • PBL210
Pablo Outdoor, poltrone • PBL80
Pablo Outdoor, pouf • PBL75P
Pablo Outdoor, tavolini • TPB130 • TPB55



These pages:
Pablo Outdoor, sofas • PBL210
Pablo Outdoor, armchairs • PBL80

Pablo Outdoor, small table • TPB130
Kyra, carpet • TY200

In queste pagine:
Pablo Outdoor, divani • PBL210
Pablo Outdoor, poltrone • PBL80

Pablo Outdoor, tavolino • TPB130
Kyra, tappeto • TY200



Opposite and next pages:
Pablo Outdoor, small tables • TPB130 • TPB55

Nella pagina accanto e nelle successive:
Pablo Outdoor, tavolini • TPB130 • TPB55





Opposite:
Pablo Outdoor, sofa • PBL210
Borea, round small table • TBE4

This page:
Pablo Outdoor, sofa • PBL210

Nella pagina accanto:
Pablo Outdoor, divano • PBL210
Borea, tavolino rotondo • TBE4

In questa pagina:
Pablo Outdoor, divano • PBL210



These pages:
Pablo Outdoor, lounge armchairs • PBL82L

In queste pagine:
Pablo Outdoor, poltrone lounge • PBL82L



Opposite:
Pablo Outdoor, lounge armchairs • PBL82L
Borea, round small table • TBE4

Next pages:
Pablo Outdoor, lounge armchair • PBL82L
Spool Outdoor, small table • OS40T

Nella pagina accanto:
Pablo Outdoor, poltrone lounge • PBL82L
Borea, tavolino rotondo • TBE4

Nelle pagine successive:
Pablo Outdoor, poltrona • BE150L • BE210L
Spool Outdoor, tavolino • OS40T



Borea

Piero Lissoni

“Borea is an airplane. It is an airplane that has landed, an airplane of 2020 but with a technological soul that perhaps comes from another century.”

Piero Lissoni

“Borea è un aeroplano. È un aeroplano che è atterrato, un aeroplano del 2020 ma con un'anima tecnologica che forse arriva da un altro secolo.”

Piero Lissoni





These pages:
Borea, sofas • BE243
Borea, armchairs • BE108

Borea, rectangular low tables • TBE121
Borea, round small tables • TBE4 - TBE8
Piet, carpet • TPI300

In queste pagine:
Borea, divani • BE243
Borea, poltrone • BE108

Borea, tavoli bassi rettangolari • TBE121
Borea, tavolini rotondi • TBE4 - TBE8
Piet, carpet • TPI300



Opposite:
 Borea, armchairs • BE108
 Borea, rectangular low table • TBE121
 Borea, round small table • TBE4
 Piet, carpet • TPI300

Nella pagina accanto:
 Borea, poltrone • BE108
 Borea, tavolo basso rettangolare • TBE121
 Borea, tavolino rotondo • TBE4
 Piet, tappeto • TPI300



These pages :
Borea, sofa • BE175
Borea, small armchairs • BE69PB
Borea, round small tables • TBE4 • TBE8

In queste pagine:
Borea, divano • BE175
Borea, poltroncine • BE69PB
Borea, tavolini rotondi • TBE4 • TBE8

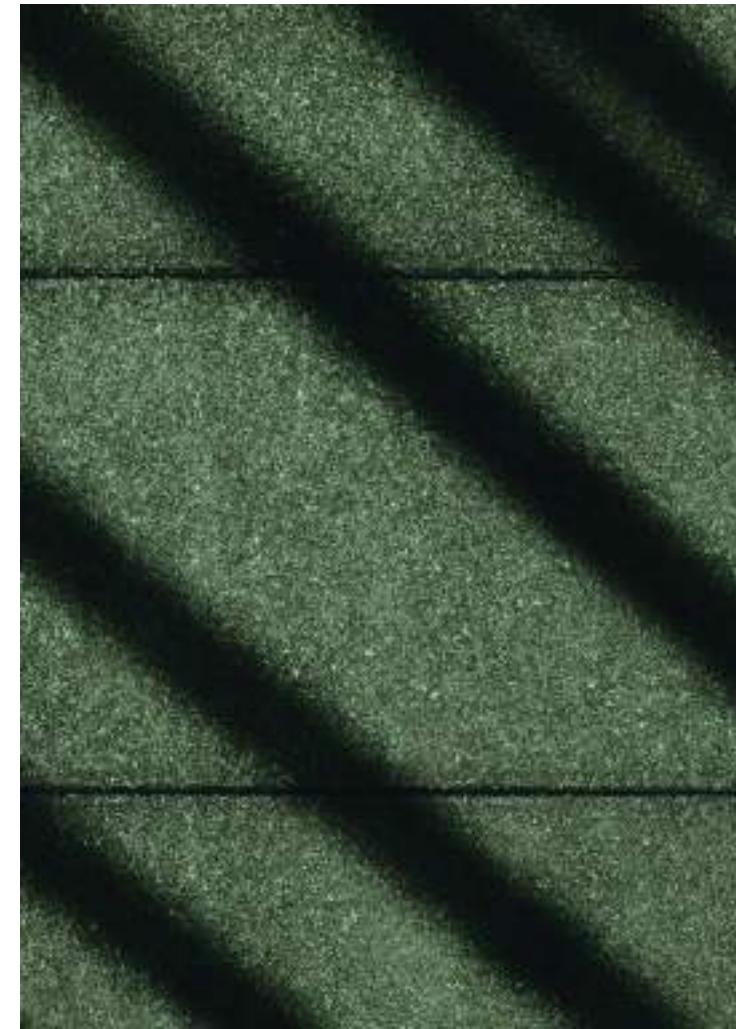

These pages:
Borea, round small tables • TBE8 • TBE4
Borea, rectangular low table • TBE121

In queste pagine:
Borea, tavolini rotondi • TBE8 • TBE4
Borea, tavolo basso rettangolare • TBE121





Previous pages:
 Borea, oval sunbed • BE210L
 Borea, round small table • TBE8

Opposite:
 Borea, oval sunbeds • BE150L • BE210L
 Borea, round small tables • TBE4 • TBE6 • TBE8

Nelle pagine precedenti:
 Borea, lettino ovale • BE210L
 Borea, tavolino rotondo • TBE8

Nella pagina accanto:
 Borea, lettini ovali • BE150L • BE210L
 Borea, tavolini rotondi • TBE4 • TBE6 • TBE8



These pages:
Borea, oval sunbed • BE210L

In queste pagine
Borea, lettino ovale • BE210L





Previous pages:
 Borea, rectangular sunbeds with small mattress • BE92L
 Spool Outdoor, small table • OS40T

These pages:
 Borea, rectangular sunbeds • BE92L

Nelle pagine precedenti:
 Borea, lettini rettangolari con materassino • BE92L
 Spool Outdoor, tavolino • OS40T

In queste pagine:
 Borea, lettini rettangolari • BE92L

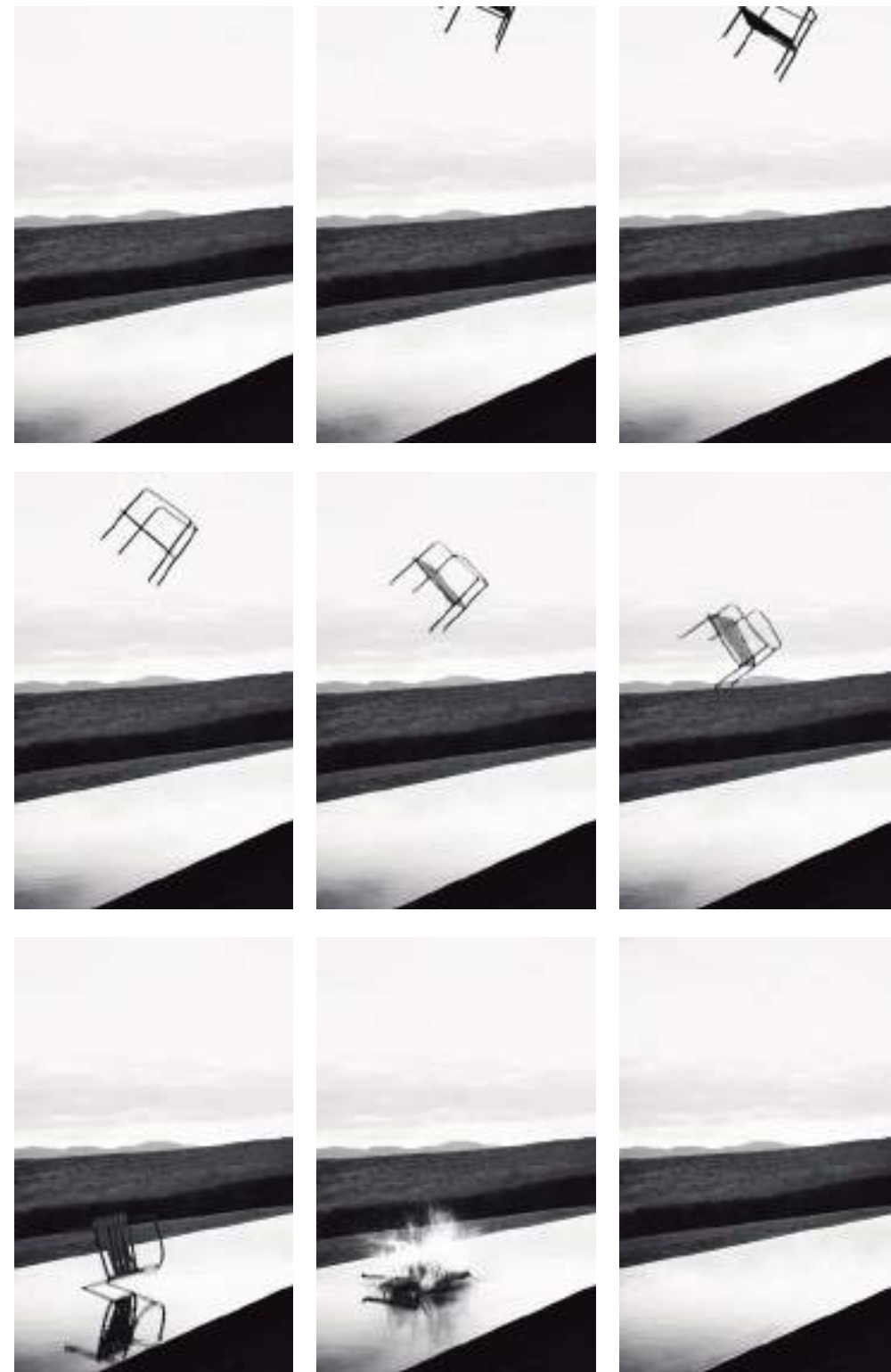

These pages:
Borea, small armchairs • BE69PB
Borea, round small tables • TBE4 • TBE6

In queste pagine:
Borea, poltroncine • BE69PB
Borea, tavolini rotondi • TBE4 • TBE6





In these pages:
Borea, table • TBE285
Borea, chairs • BE69PA

In queste pagine:
Borea, tavolo • TBE285
Borea, sedie • BE69PA



Opposite and next pages:
Borea, table • TBE285
Borea, chairs • BE69PA

Nella pagina accanto e nelle successive:
Borea, tavolo • TBE285
Borea, sedie • BE69PA





Ayana

Naoto Fukasawa

Minimalist and innovative, Ayana collection it sees wood as the protagonist with a pleasant oriental touch.

Minimalista e innovativa, la collezione Ayana vede come protagonista il legno con un piacevole tocco orientale.





These pages:
 Ayana, sofa • AY263
 Ayana, armchairs • AY86P

Ayana, low table • TAY180
 Colosseo Outdoor, service elements • OCL40T • OCL45T
 Kyra, carpets • TY200

In queste pagine:
 Ayana, divano • AY263
 Ayana, poltrone • AY86P

Ayana, tavolo basso • TAY180
 Colosseo Outdoor, elementi di servizio • OCL40T • OCL45T
 Kyra, tappeti • TY200

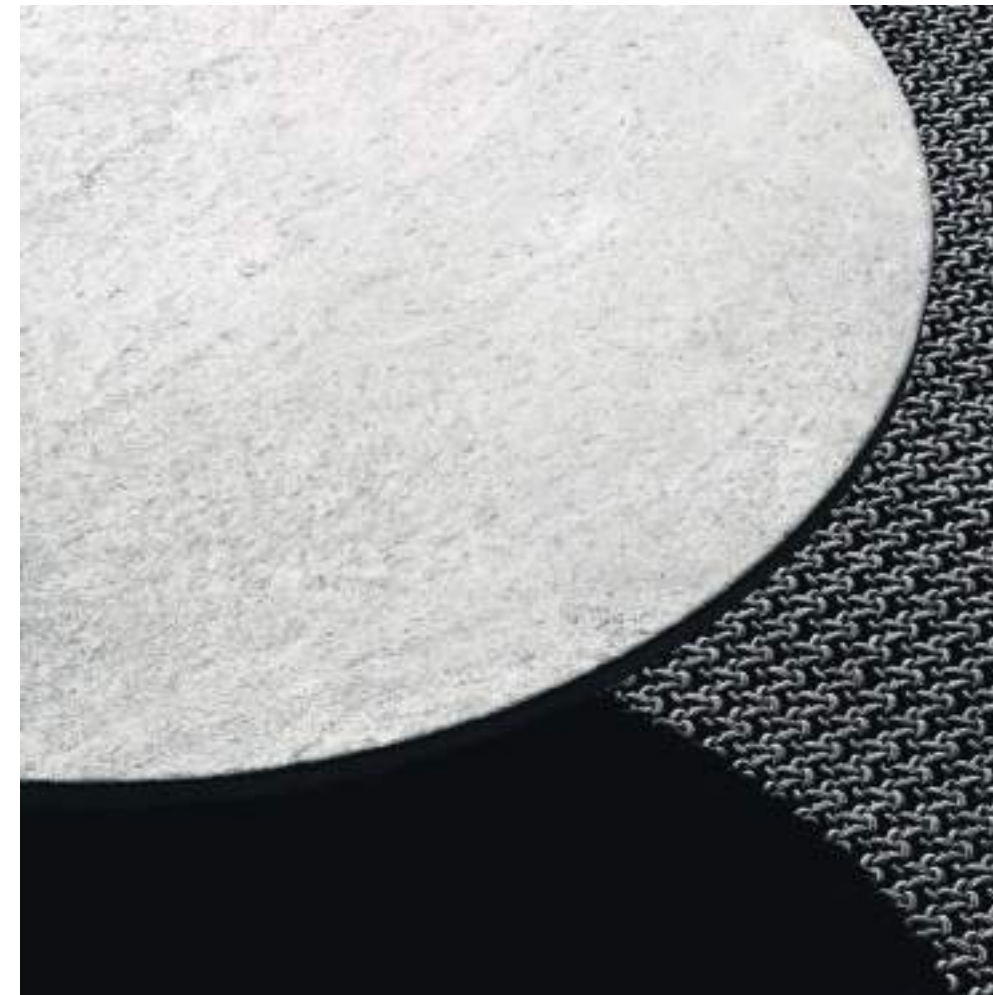

Opposite:
 Ayana, sofa • AY263
 Ayana, low table • TAY180
 Colosseo Outdoor, service element • OCL40T
 Kyra, carpets • TY200

Nella pagina accanto:
 Ayana, divano • AY263
 Ayana, tavolo basso • TAY180
 Colosseo Outdoor, elemento di servizio • OCL40T
 Kyra, tappeti • TY200



These pages:

Ayana, sofa • AY263
Ayana, armchairs • AY86P
Ayana, low table • TAY180
Kyra, carpets • TY200

In queste pagine:

Ayana, divano • AY263
Ayana, poltrone • AY86P
Ayana, tavolo basso • TAY180
Kyra, tappeti • TY200



These pages:
 Ayana, sofas • AY210
 Ayana, armchair • AY86P

Ayana, low table • TAY180
 Colosseo Outdoor, service elements • OCL40T
 Kyra, carpets • TY200

In queste pagine:
 Ayana, divani • AY210
 Ayana, poltrona • AY86P

Ayana, tavolo basso • TAY180
 Colosseo Outdoor, elemento di servizio • OCL40T
 Kyra, tappeti • TY200



Opposite:
Ayana, table • TAY230
Ayana, chairs • AY58S

Hospes, ottoman • HE2
Kyra, carpet • TY200

Nella pagina accanto:
Ayana, tavolo • TAY230
Ayana, sedie • AY58S

Hospes, pouf • HE2
Kyra, tappeto • TY200

Hybrid

Antonio Citterio

Hybrid is an innovative system of modular seating elements that represents a real link between the inside and the outside of the house.

Hybrid è un sistema di sedute modulare che rappresenta il vero anello di congiunzione tra l'interno e l'esterno della casa.





These pages:
 Hybrid, modular sofa • HY134L_2 • HY134L
 Hybrid, chaise longue • HY134L_2 • HY200L

Gio, low table • TGO18
 Fat-Fat Outdoor, small tables • OTF62G • OTF92G
 Tramae, ottomans • TRM60P • TRM90P

Twist, carpets • TW200

In queste pagine:
 Hybrid, divano componibile • HY134L_2 • HY134L
 Hybrid, chaise longue • HY134L_2 • HY200L

Gio, tavolo basso • TGO18
 Fat-Fat Outdoor, tavolini • OTF62G • OTF92G
 Tramae, pouf • TRM60P • TRM90P

Twist, tappeti • TW200



These pages:
 Hybrid, chaise longue • HY134L_2 • HY200L
 Gio, low table • TGO18 Gio, small table • TGO6

Gio, armchairs • G064
 Tramae, ottoman • TRM60P
 Twist, carpet • TW200

In queste pagine:
 Hybrid, chaise longue • HY134L_2 • HY200L
 Gio, tavolo basso • TGO18 Gio, tavolino • TGO6

Gio, poltrone • G064
 Tramae, pouf • TRM60P
 Twist, tappeto • TW200



Opposite:
Hybrid, sofa • 9HY222
Tramae, ottoman • TRM60P

Fat-Fat Outdoor, small tables • OTF62G • OTF92G
Kyra, carpet • TY200

Nella pagina accanto:
Hybrid, divano • 9HY222
Tramae, pouf • TRM60P

Fat-Fat Outdoor, tavolini • OTF62G • OTF92G
Kyra, tappeto • TY200



These pages:
 Hybrid, sofas • 9HY266C • HY266C
 Tramae, ottomans • TRM47P • TRM60P

Canasta, low tables • TCN15
 Canasta '13, small table • TCNC3
 Kyra, carpet • TY200

In queste pagine:
 Hybrid, divani • 9HY266C • HY266C
 Tramae, pouf • TRM47P • TRM60P

Canasta, tavoli bassi • TCN15
 Canasta '13, tavolino • TCNC3
 Kyra, tappeto • TY200



These pages:
 Hybrid, modular sofa • 9HY178PA • 9HY200T_1
 Hybrid, ottoman • HY178P
 Erica '19, small armchairs • NE80P
 Mirto Outdoor, console • TMO162_6
 Mirto Outdoor, low tables • TMO162_4
 Frank Outdoor, ottoman • OF58P
 Kyra, carpet • TY200

In queste pagine:
 Hybrid, divano componibile • 9HY178PA • 9HY200T_1
 Hybrid, pouf • HY178P
 Erica '19, poltroncine • NE80P
 Mirto Outdoor, console • TMO162_6
 Mirto Outdoor, tavoli bassi • TMO162_4
 Frank Outdoor, pouf • OF58P
 Kyra, tappeto • TY200

Oh, it rains!

Philippe Stark

Innovation, technology, high quality and comfort are the key characteristics of this visionary new collection.

Innovazione, tecnologia, alta qualità e comfort sono le caratteristiche principali di questa nuova collezione visionaria.





These pages:
Oh, it rains!, sofas • OH280 • TOH1
Frank Outdoor, ottoman • OF58P

*Cosmos Outdoor, small tables
*B&B Italia archive

In queste pagine:
Oh, it rains!, divani • OH280 • TOH1
Frank Outdoor, pouf • OF58P

*Cosmos Outdoor, tavolini
*Archivio B&B Italia



This page:
Oh, it rains!, armchair • OH140PS • TOH1

In questa pagina:
Oh, it rains!, poltrona • OH140PS • TOH1







Previous pages:
 Oh, it rains!, sofas • OH280 • TOH1
 *Cosmos Outdoor, small tables
 *B&B Italia archive

Opposite:
 Oh, it rains!, sofa • OH280 • TOH1

Nelle pagine precedenti:
 Oh, it rains!, divani • OH280 • TOH1
 *Cosmos Outdoor, small tables
 *Archivio B&B Italia

Nella pagina accanto:
 Oh, it rains!, divano • OH280 • TOH1



Ribes

Antonio Citterio



The starting point is a futon base with flexible glass-fibre slats resting on an aluminium frame.

Il punto di partenza è una base "futon" con doghe flessibili in fibra di vetro, appoggiate su una struttura in alluminio.



These pages:
 Ribes, modular sofa • RBR141LB_2 • RBR190PA
 Erica '19, small armchairs • NESOP

Frank Outdoor, ottomans • OF58P
 Canasta, low table • TCN15
 Canasta '13, small tables • TCNC3

Kyra, carpets • TY200
 Karam, floor baskets • KA02

In queste pagine:
 Ribes, divano componibile • RBR141LB_2 • RBR190PA
 Erica '19, poltroncine • NESOP

Frank Outdoor, pouf • OF58P
 Canasta, tavolo basso • TCN15
 Canasta '13, tavolini • TCNC3

Kyra, tappeti • TY200
 Karam, ceste da terra • KA02



Opposite:
Ribes, modular sofa • RB141LB_2 • RB141LB_2
Erica '19, small armchair • NES0P

Canasta, low table • TCN15
Canasta '13, small table • TCNC3
Kyra, carpets • TY200

Nella pagina accanto:
Ribes, divano componibile • RB141LB_2 • RB141LB_2
Erica '19, poltroncina • NES0P

Canasta, tavolo basso • TCN15
Canasta '13, tavolino • TCNC3
Kyra, tappeti • TY200





These pages:

Ribes, modular sofa • RBR145LB_1
Mirto Outdoor, folding small armchairs • MI59N

Fat-Fat Outdoor, trays • OF42V • OF62V
Kyra, carpets • TY200
Karam, floor baskets • KA02

Mirto Outdoor, table • TM0162Q
Erica '19, stackable chairs • NE61S_I
Frank Outdoor, ottoman • OF58P

In queste pagine:

Ribes, divano componibile • RBR145LB_1
Mirto Outdoor, poltroncine pieghevoli • MI59N

Fat-Fat Outdoor, vassoi • OF42V • OF62V
Kyra, tappeti • TY200
Karam, ceste da terra • KA02

Mirto Outdoor, tavolo • TM0162Q
Erica '19, sedie impilabili • NE61S_I
Frank Outdoor, pouf • OF58P





Previous and these pages:
 Ribes, modular sofa • RBR141LB_3 • RB201T_3
 Mirto Outdoor, folding small armchair • MI59N

Frank Outdoor, ottoman • OF58P
 Fat-Fat Outdoor, small table • OTF62A
 Fat-Fat Outdoor, tray • OF42V

Karam, floor baskets • KA02
 Kyra, carpets • TY200

In queste pagine e nelle precedenti:
 Ribes, divano componibile • RBR141LB_3 • RB201T_3
 Mirto Outdoor, poltroncina pieghevole • MI59N

Frank Outdoor, pouf • OF58P
 Fat-Fat Outdoor, tavolino • OTF62A
 Fat-Fat Outdoor, vassoio • OF42V

Karam, ceste da terra • KA02
 Kyra, tappeti • TY200





These pages:
 Ribes, modular sofa • RB201T_4 • RB201T_3
 Erica '19, small armchairs • NESOP

Fat-Fat Outdoor, small tables • OTF92G • OTF62 • OTF62A
 Kyra, carpets • TY200

In queste pagine:
 Ribes, divano componibile • RB201T_4 • RB201T_3
 Erica '19, poltroncine • NESOP

Fat-Fat Outdoor, tavolini • OTF92G • OTF62 • OTF62A
 Kyra, tappeti • TY200



Nella pagina accanto e in questa pagina:
Ribes, chaise longue • RB130PQ_1
Twist, tappeto • TW200

Nelle pagine successive:
Ribes, chaise longue • RB130PQ_1
Twist, tappeto • TW200

*Cosmos Outdoor, tavolino
*Archivio B&B Italia

Opposite and this page:
Ribes, chaise longue • RB130PQ_1
Twist, carpet • TW200

Next pages:
Ribes, chaise longue • RB130PQ_1
Twist, carpet • TW200

*Cosmos Outdoor, small table
*B&B Italia archive



Erica • Erica '19

Antonio Citterio

The lightness and the design of the elements make them ideal for both public and residential settings, featuring set and back cushions for ergonomic comfort together with strength for outdoor use. A real invitation to relax.

La leggerezza e il disegno degli elementi ne suggeriscono l'utilizzo sia in spazi pubblici che residenziali, rispettando criteri di ergonomia e adattabilità ambientale.

Un vero e proprio invito al relax.





These pages:
Erica '19, sofa • NE153
Erica '19, small armchairs • NE80P

Fat-Fat Outdoor, small tables • OFT62 • OFT42

In queste pagine:
Erica '19, divano • NE153
Erica '19, poltroncine • NE80P

Fat-Fat Outdoor, tavolini • OFT62 • OFT42



Opposite:
Erica '19, sofa • 9NE170
Fat-Fat Outdoor, small tables • OFT62 • OFT42
Kyra, carpets • TY200

Nella pagina accanto:
Erica '19, divano • 9NE170
Fat-Fat Outdoor, tavolini • OFT62 • OFT42
Kyra, tappeti • TY200



These pages:
Erica '19, sofa • 9NE170
Erica '19, small armchairs • NE80P
Fat-Fat Outdoor, small tables • OFT62 • OFT42
Kyra, carpets • TY200

In queste pagine:
Erica '19, divano • 9NE170
Erica '19, poltroncine • NE80P
Fat-Fat Outdoor, tavolini • OFT62 • OFT42
Kyra, tappeti • TY200



Opposite:
Erica' 19, stackable chairs • NE61S_I
Mirto Outdoor, table • TM0222

Kyra, carpets • TY200

Nella pagina accanto:
Erica '19, sedie impilabili • NE61S_I
Mirto Outdoor, tavolo • TM0222

Kyra, tappeti • TY200



These pages:
Erica, sofa • E216
Erica, armchairs • E90P

Mirto Outdoor, low table • MI180_4G
Mirto Outdoor, console • MI200_6G
Twist, carpets • TW300

In queste pagine:
Erica, divano • E216
Erica, poltrone • E90P

Mirto Outdoor, tavolo basso • MI180_4G
Mirto Outdoor, console • MI200_6G
Twist, tappeti • TW300

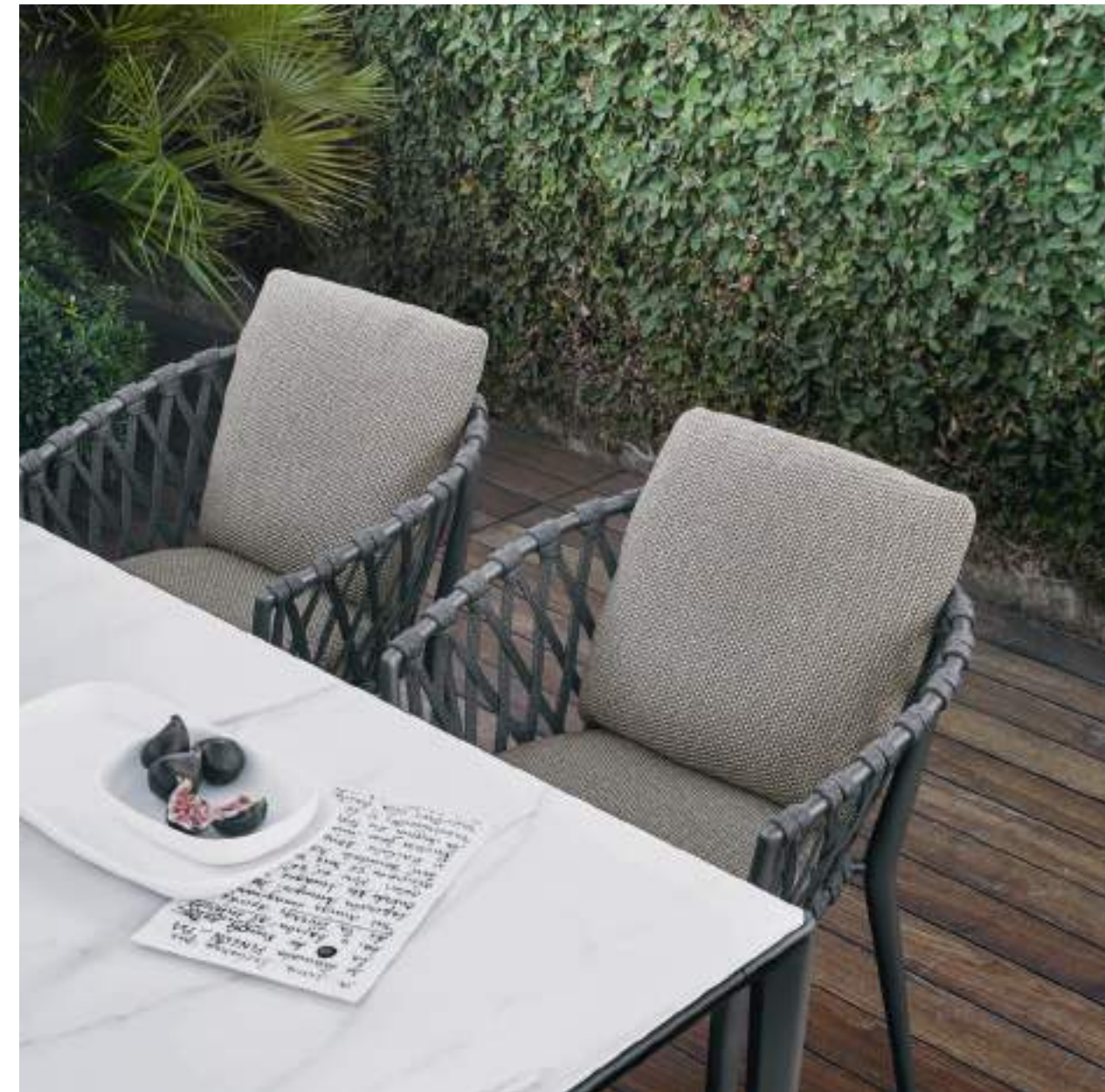

Opposite:
Erica, sofa • E170
Erica, armchair • E90P

Pushpam, small table • TF100RB
Twist, carpets • TW300

This page:
Erica, chairs • E61S
Mirro Outdoor, table • MI250TG

Nella pagina accanto:
Erica, divano • E170
Erica, poltrona • E90P

Pushpam, tavolino • TF100RB
Twist, tappeti • TW300

In questa pagina:
Erica, sedie • EE61S
Mirro Outdoor, tavolo • MI250TG

Mirto Outdoor

Antonio Citterio

The quality and attention to details make Mirto a collection that is made to last.

L'aspetto qualitativo e la cura dei dettagli fanno di Mirto una collezione fatta per durare nel tempo.







Previous and these pages:
Mirto Outdoor, sunbeds • MI200CL
Mirto Outdoor, small tables • MI54T

In queste pagine e nelle precedenti:
Mirto Outdoor, lettini • MI200CL
Mirto Outdoor, tavolini • MI54T



These and next page:
Mirto Outdoor, table • MI250TG
Mirto Outdoor, chairs • MI5SS

Mirto Outdoor, small armchairs • MI65P
Mirto Outdoor, console • MI250_6G
Twist, carpet • TW300

In queste pagine e nella successiva:
Mirto Outdoor, tavolo • MI250TG
Mirto Outdoor, sedie • MI5SS

Mirto Outdoor, poltroncine • MI65P
Mirto Outdoor, console • MI250_6G
Twist, tappeto • TW300



This page:
 Mirto Outdoor, low table • MI120_4G
 Twist, carpet • TW300

White Collection, vase • AB20046B
 Bunch, vase • AB20031B
 see catalogue B&B Italia "The Collection"

In questa pagina:
 Mirto Outdoor, tavolo basso • MI120_4G
 Twist, tappeto • TW300

White Collection, vaso • AB20046B
 Bunch, vaso • AB20031B
 vedi catalogo B&B Italia "The Collection"





These pages:

Mirto Outdoor, table • TMO162Q
Mirto Outdoor, folding small armchairs • MI59N
Frank Outdoor, ottoman • OF58P
Fat-Fat Outdoor, tray • OF42V
Kyra, carpets • TY200

In queste pagine:

Mirto Outdoor, tavolo • TMO162Q
Mirto Outdoor, poltroncine pieghevoli • MI59N
Frank Outdoor, pouf • OF58P
Fat-Fat Outdoor, vassoio • OF42V
Kyra, tappeti • TY200



These pages:
 Mirto Outdoor, table • TMO162Q
 Mirto Outdoor, folding small armchairs • MI59N

Frank Outdoor, ottoman • OF58P
 Fat-Fat Outdoor, tray • OF42V
 Kyra, carpets • TY200

In queste pagine:
 Mirto Outdoor, tavolo • TMO162Q
 Mirto Outdoor, poltroncine pieghevoli • MI59N

Frank Outdoor, pouf • OF58P
 Fat-Fat Outdoor, vassoio • OF42V
 Kyra, tappeti • TY200





Opposite:
 Mirto Outdoor, low table • TM0162_4
 Mirto Outdoor, small table • MI54T
 Frank Outdoor, ottomans • OF58P

Ribes, modular sofa • RBR141LB_2 • RBR190PA
 Kyra, carpets • TY200
 Karam, floor baskets • KA02

Nella pagina accanto:
 Mirto Outdoor, tavolo basso • TM0162_4
 Mirto Outdoor, tavolino • MI54T
 Frank Outdoor, pouf • OF58P

Ribes, divano componibile • RBR141LB_2 • RBR190PA
 Kyra, tappeti • TY200
 Karam, ceste da terra • KA02



Ray Outdoor Fabric • Natural

Antonio Citterio

Both featured by structures covered with interlaced materials: Ray Outdoor is created using a ribbon pattern composed by polypropylene fibres resistant to UV rays and weathering; while Ray Outdoor Natural features an interlacing rope pattern reminiscent of Manila hemp, in perfect harmony with nature.

Entrambi caratterizzati dalla struttura rivestita ad intreccio, Ray Outdoor Fabric si distingue per l'intreccio a nastro realizzato in fibra di polipropilene resistente ai raggi UV ed agli agenti atmosferici, Ray Outdoor Natural per l'intreccio a "corda" che si rifà all'abaca naturale, in perfetta armonia con la natura.





These pages:
 Ray Outdoor Fabric, armchairs • RF85
 Ray Outdoor Fabric, modular sofa • RF235D • RF235LS

Gio, low table • TGO12
 Gio, small tables TGO6
 Fat-Sofa Outdoor, ottoman • FA61P

Kaleidos, carpets • TKA300

In queste pagine:
 Ray Outdoor Fabric, poltrone • RF85
 Ray Outdoor Fabric, divano componibile • RF235D • RF235LS

Gio, tavolo basso • TGO12
 Gio, tavolino • TGO6
 Fat-Sofa Outdoor, pouf • FA61P

Kaleidos, tappeti • TKA300

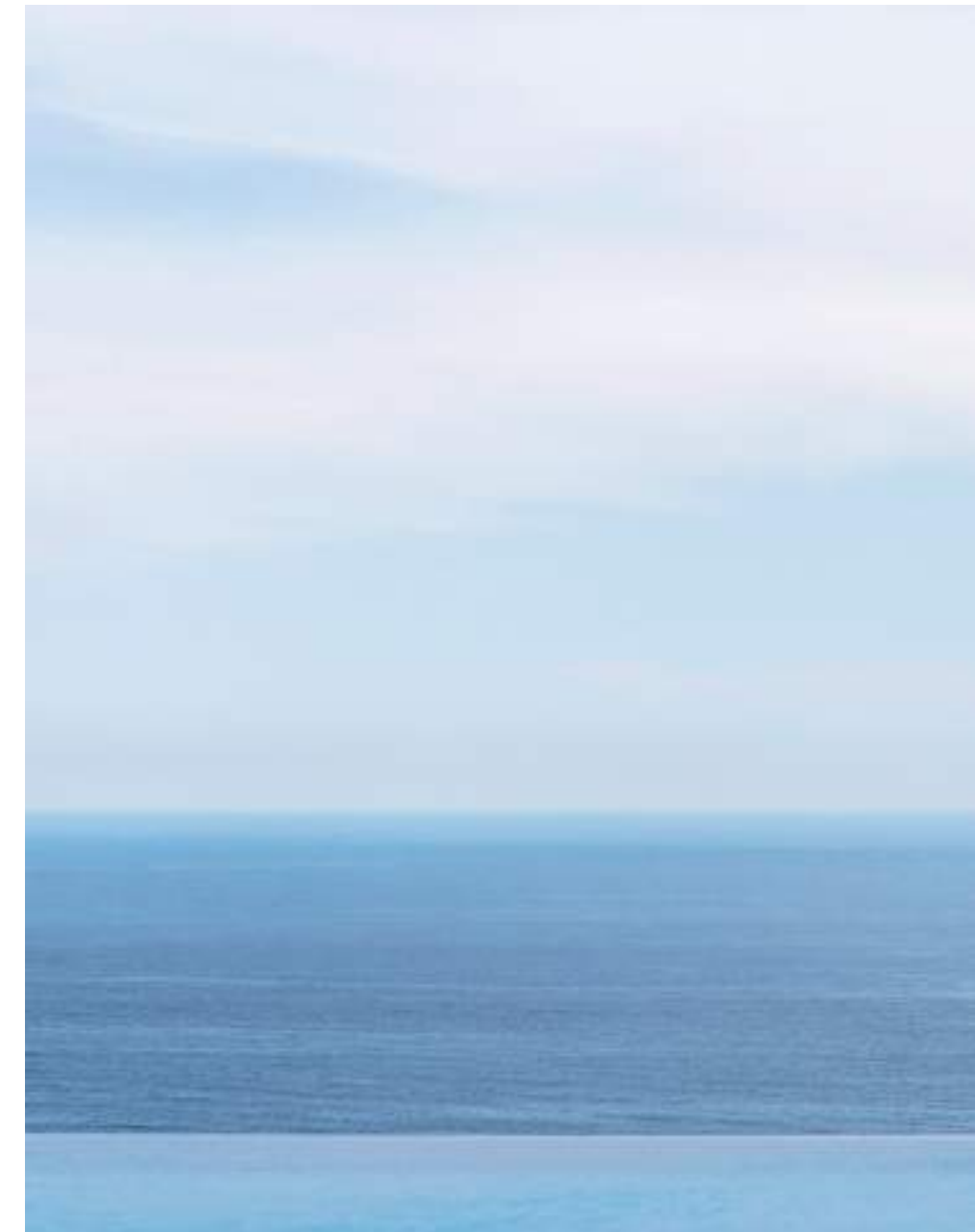

Opposite:
Ray Outdoor Fabric, armchairs • RF85
Gio, low table • TGO12

Kaleidos, carpet • TKA300

Nella pagina accanto:
Ray Outdoor Fabric, poltrone • RF85
Gio, tavolo basso • TGO12

Kaleidos, tappeto • TKA300



These pages:
Ray Outdoor Fabric, sunbeds • RF203LA
Gio, small table • TG06
Husk Outdoor, tray • HT062V

In queste pagine:
Ray Outdoor Fabric, lettini • RF203LA
Gio, tavolino • TG06
Husk Outdoor, vassoio • HT062V



These pages: Ray Outdoor Natural, sofa • RNL236_B
Ray Outdoor Natural, chaise longue • RN236LD_B
Ray Outdoor Natural, armchairs • RN86_B

Gio, low table • TGO18
Gio, small table • TGO6
Twist, carpets • TW300

In queste pagine: Ray Outdoor Natural, divano • RNL236_B
Ray Outdoor Natural, chaise longue • RN236LD_B
Ray Outdoor Natural, poltrone • RN86_B

Gio, tavolo basso • TGO18
Gio, tavolino • TGO6
Twist, tappeti • TW300

Gio

Antonio Citterio

The solid teak structure with a special antique grey finish, gives the wood a particular lived-in aspect and silver-grey reflective quality.

La struttura in massello di teak nella speciale finitura antique grey, conferisce al legno un particolare aspetto vissuto con riflessi grigio argento.





These pages:

Gio, modular sofa • G0233TD • G0197AD • G0197AS
Gio, low table • TGO12 Gio, small table • TGO6

In queste pagine:

Gio, divano componibile • G0233TD • G0197AD • G0197AS
Gio, tavolo basso • TGO12 Gio, tavolino • TGO6



Opposite:
Gio, sofa • G0238
Gio, armchair • G064
Gio, low table • TG018

Nella pagina accanto:
Gio, divano • G0238
Gio, poltrona • G064
Gio, tavolo basso • TG018



These pages:
Gio, sunbeds • G0200L
Gio, small tables • TG06

In queste pagine:
Gio, lettini • G0200L
Gio, tavolini • TG06



Opposite:
Gio, table • TG0280
Gio, chairs • G058
Gio, bench • G0130P

Nella pagina accanto:
Gio, tavolo • TG0280
Gio, sedie • G058
Gio, panca • G0130P



Charles Outdoor

Antonio Citterio

Characteristics that made it a classic of pure contemporary taste have been left unchanged.

Rimangono inalterate le caratteristiche che lo hanno reso un classico dal gusto decisamente contemporaneo.

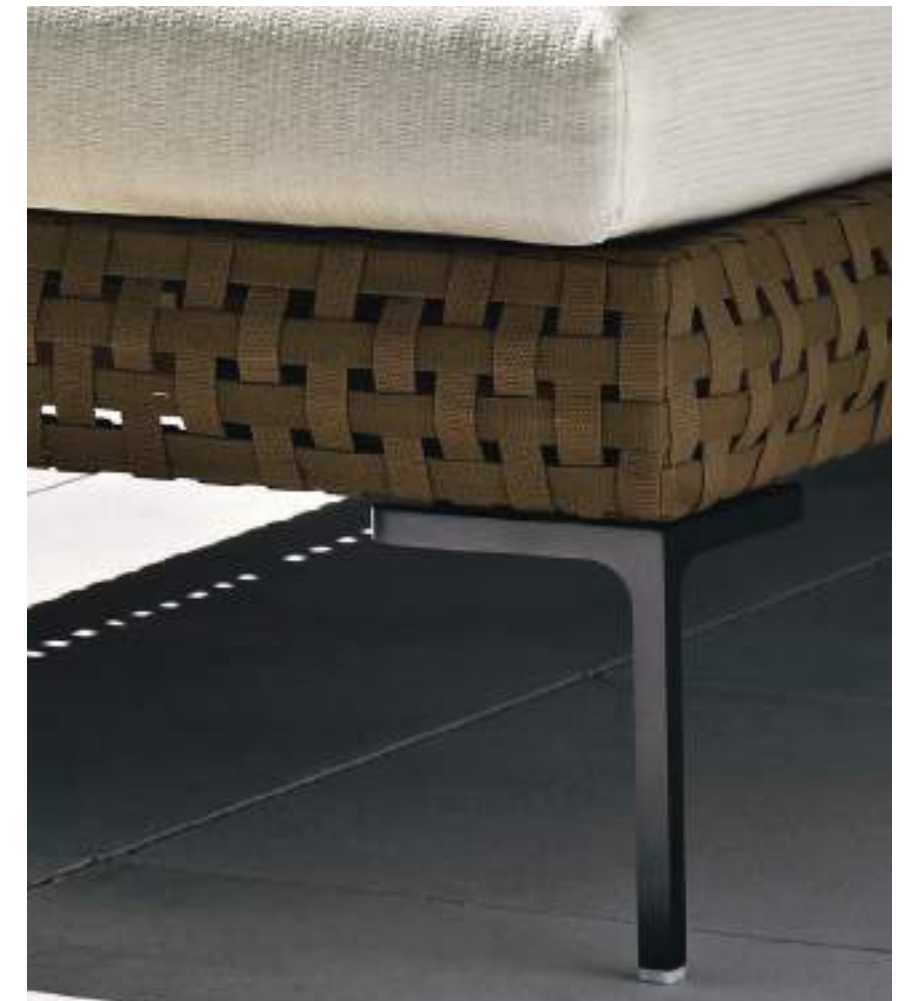



These pages:
Charles Outdoor, modular sofa
CHO160LS • CHO234D

Charles Outdoor, armchair • CH084
Springtime, small table • TST7
Husk Outdoor, tray • HTO62V

*Reel, service element
*B&B Italia archive

In queste pagine:
Charles Outdoor, divano componibile
CHO160LS • CHO234D

Charles Outdoor, poltrona • CH084
Springtime, tavolino • TST7
Husk Outdoor, vassoio • HTO62V

*Reel, elemento di servizio
*Archivio B&B Italia



Opposite:
Charles Outdoor, modular sofa
CHO160LS • CHO234D

Nella pagina accanto:
Charles Outdoor, divano componibile
CHO160LS • CHO234D



This page:
Charles Outdoor, armchair • CH084
Springtime, small table • TST7

In questa pagina:
Charles Outdoor, poltrona • CH084
Springtime, tavolino • TST7

Ginepro

Antonio Citterio

The new table is made with an anthracite painted aluminum structure and a Serpentine stone top, extremely durable and precious as the linear and timeless style.

Il nuovo tavolo è realizzato con struttura in alluminio verniciato antracite e piano in pietra Serpentino, estremamente durevole e pregiata in linea con lo stile lineare e senza tempo.





These pages:
Ginepro, table • TGS250
Erica, chairs • E61S

Hospes, ottomans • HE1 • HE2
Kyra, carpet • TY200

In queste pagine:
Ginepro, tavolo • TGS250
Erica, sedie • E61S

Hospes, pouf • HE1 • HE2
Kyra, tappeto • TY200



Opposite:
Ginepro, table • TGS105R
Erica, chairs • E61S

Hospes, ottoman • HE2

Nella pagina accanto:
Ginepro, tavolo • TGS105R
Erica, sedie • E61S

Hospes, pouf • HE2



Bay

Nipa Doshi & Jonathan Levien



A collection of sculptural and monolithic yet visually light outdoor seats.

Una collezione di sedute da esterno dall'aspetto scultoreo e monolitico, al contempo visivamente leggero.



This pages:

Bay, sofa • BY176CL

Bay, small armchair • BY94N

Bay, ottomans • BY74PQ

Tobi-Ishi Outdoor, low table • OT146

Kyra, carpets • TY200

In queste pagine:

Bay, divano • BY176CL

Bay, poltroncina • BY94N

Bay, pouf • BY74PQ

Tobi-Ishi Outdoor, tavolo basso • OT146

Kyra, tappeti • TY200



This pages:

Bay, sofa • BY176CL
 Bay, small armchair • BY94N
 Bay, ottoman • BY74PQ
 Tobi-Ishi Outdoor, low table • OT146
 Kyra, carpets • TY200

In queste pagine:

Bay, divano • BY176CL
 Bay, poltroncina • BY94N
 Bay, pouf • BY74PQ
 Tobi-Ishi Outdoor, tavolo basso • OT146
 Kyra, tappeti • TY200



These pages:
 Bay, sofa • BY236
 Bay, armchair with high back • BY123A

*Tabour Outdoor, ottoman
 *B&B Italia archive
 Twist, carpets • TW300

In queste pagine:
 Bay, divano • BY236
 Bay, poltrona con schienale alto • BY123A

*Tabour Outdoor, pouf
 *Archivio B&B Italia
 Twist, tappeti • TW300

Ginestra

Antonio Citterio

Sinuous harmonious lines clearly inspired by northern trends. It is characterised by an interlacing in polypropylene fibre that is ideal for outdoor use.

Dalle linee sinuose e fluide di chiara ispirazione nordica, caratterizzata da un intreccio di nastri in tessuto sintetico adatto all'utilizzo outdoor.





These pages:
Ginestra, table • GN280T
Ginestra, chairs • GN60

Twist, carpets • TW300

In queste pagine:
Ginestra, tavolo • GN280T
Ginestra, sedie • GN60

Twist, tappeti • TW300



Opposite:
Ginestra, table • GN180TR
Ginestra, chairs • GN60

Nella pagina accanto:
Ginestra, tavolo • GN180TR
Ginestra, sedie • GN60



Butterfly

Patricia Urquiola

Its name comes from the “butterfly” shape created by the outer corner that joins the armrest and the backrest.

Prende il suo nome dalla forma a “farfalla” che disegna l’angolo esterno di unione tra bracciolo e schienale.





These and next pages:
Butterfly, modular sofa
BT112S • BT90C • BT112D

Butterfly, small tables • BT9R • BT7

In queste pagine e nelle successive:
Butterfly, divano componibile
BT112S • BT90C • BT112D

Butterfly, tavolini • BT9R • BT7

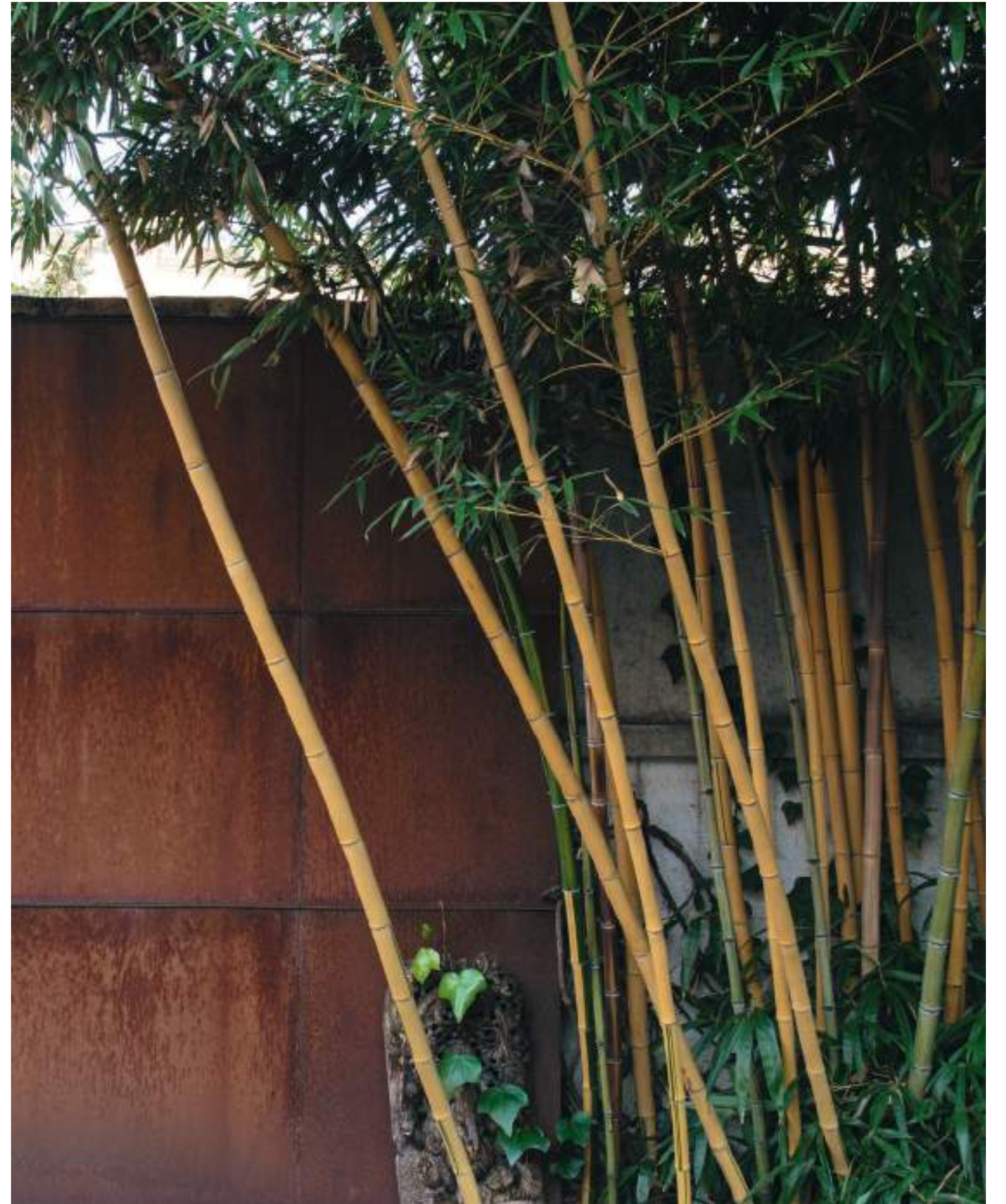



These pages:
Butterfly, modular sofa
BT112S • BT90C • BT90P • BT112D

Butterfly, ottomans • BT90P
Butterfly, low table • BT15
Overscale Flames Outdoor, oil candles • AB20044B

In queste pagine:
Butterfly, divano componibile
BT112S • BT90C • BT90P • BT112D

Butterfly, pouf • BT90P
Butterfly, tavolo basso • BT15
Overscale Flames Outdoor, candele ad olio • AB20044B

Fat-Sofa Outdoor

Patricia Urquiola

The rounded, soft and sinuous shapes of the Fat-Sofa seating system are the base for the outdoor version, characterized by a brand new interlacing design.

Le forme arrotondate, morbide e sinuose del sistema di sedute Fat-Sofa vengono riprese nella versione da esterni, caratterizzata da un'inedita proposta di intreccio.





These pages:
Fat-Sofa Outdoor, sofa • FA230
Fat-Sofa Outdoor, armchairs with high back • FA91A

Butterfly, low table • BT15

In queste pagine:
Fat-Sofa Outdoor, divano • FA230

Fat-Sofa Outdoor, poltrone con schienale alto • FA91A
Butterfly, tavolo basso • BT15



This page:
Fat-Sofa Outdoor, sofa • FA150
Husk Outdoor, tray • HTO62V

In questa pagina:
Fat-Sofa Outdoor, divano • FA150
Husk Outdoor, vassoio • HTO62V

Canasta. Canasta '13

Patricia Urquiola

For Canasta, the play between classic and contemporary is not a new idea: the Viennese cane inspiration is retro, and the polyethylene texture speaks today's language.

The Canasta' 13 series maintain the iconic design and the typologies of the entire Canasta series, but with a new look designed to blend in with the external environment even more.

Per Canasta, il gioco tra il classico ed il contemporaneo è senza alcuna nostalgia: se l'ispirazione alla paglia di Vienna è retro, la texture in polietilene parla il linguaggio di oggi. La serie Canasta '13 mantiene il design iconico e le tipologie di tutta la serie Canasta e cambia "veste" per fondersi maggiormente con l'ambiente esterno.

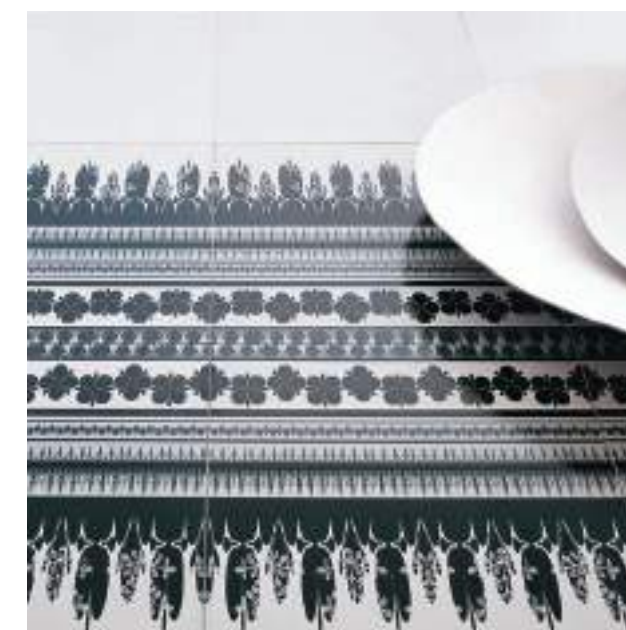



These pages:
Canasta '13, sofas • CNC160P1

In queste pagine:
Canasta '13, divani • CNC160P1



In this page:
Canasta '13, small tables • TCNC3 • TCNC4

In questa pagina:
Canasta '13, tavolini • TCNC3 • TCNC4



In this page:
Canasta '13, armchair with high back • CNC98PA
Canasta '13, service element • PCNC60

In questa pagina:
Canasta '13, poltrona con schienale alto • CNC98PA
Canasta '13, elemento di servizio • PCNC60



These pages:
Canasta, sofa with canopy and wheels
CN160P1 • CN160P1W • CN160P1C

Canasta '13, small tables • TCNC3 • TCNC4

In queste pagine:
Canasta, divano con capote e ruote
CN160P1 • CN160P1W • CN160P1C

Canasta '13, tavolini • TCNC3 • TCNC4



These pages:
Canasta, sofa • CN160P1
Canasta, armchairs with high back • CN98PA

In queste pagine:
Canasta, divano • CN160P1
Canasta, poltrone con schienale alto • CN98PA





Opposite:
Canasta, table • TCN283N
Crinoline, chairs • C2P

White Collection, stool • AB20048B

Nella pagina accanto:
Canasta, tavolo • TCN283N
Crinoline, sedie • C2P

White Collection, sgabello • AB20048B

Opposite:
Canasta, low table • TCN12
Canasta '13, small table • TCNC4

Joker, vases • AB20036 • AB20037
see catalogue B&B italia "The Collection"

Nella pagina accanto:
Canasta, tavolo basso • TCN12
Canasta '13, tavolino • TCNC4

Joker, vasi • AB20036 • AB20037
vedi catalogo B&B Italia "The Collection"

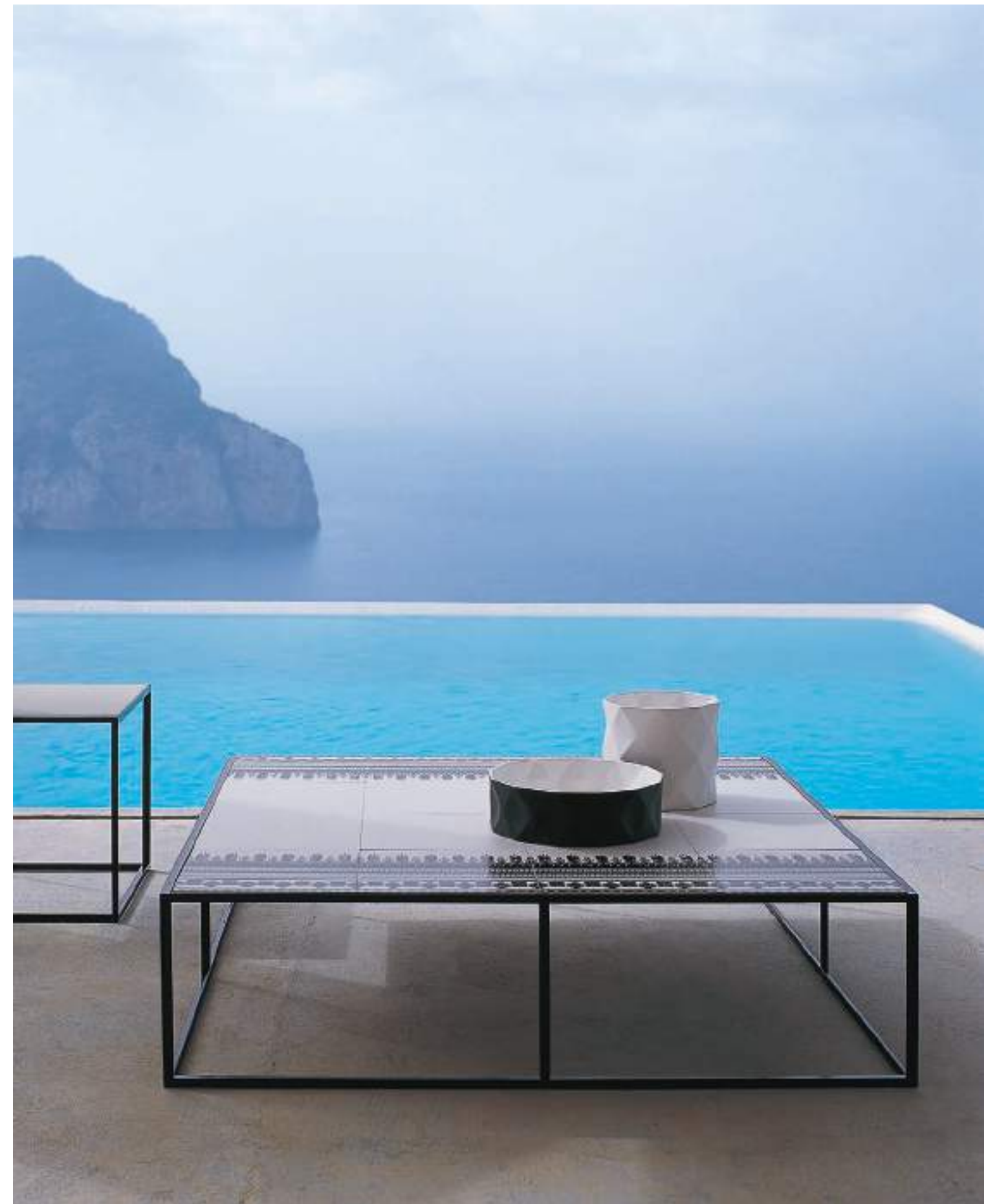

Crinoline

Patricia Urquiola

Can you picture the dresses that women wore in the 1800s? Full, bell-shaped skirts held by crinolines (rigid underskirt garments) were spectacular “micro-architectures”.

Avete presente le gonne delle dame ottocentesche? Gonfie, a campana, sostenute dalle crinoline (sottogonne rigide). Erano scenografiche micro-architetture da salotto.





These pages:
Crinoline, armchairs C5C • C5P

In queste pagine:
Crinoline, poltrone C5C • C5P



These pages:
Crinoline, armchairs • C5P

Opposite:
Crinoline, chairs with armrests • C2PF
Tobi-Ishi Outdoor, table • OT162

In queste pagine:
Crinoline, poltrone • C5P

Nella pagina accanto:
Crinoline, sedie con braccioli • C2PF
Tobi-Ishi Outdoor, tavolo • OT162



Tobi-Ishi Outdoor

Edward Barber & Jay Osgerby

The name and inspiration come from the smooth stones “tobi-ishi” used as ornaments in traditional Zen gardens.

Il nome e l'ispirazione sono un riferimento alle pietre levigate “tobi-ishi” usate con funzione ornamentale nei tradizionali giardini zen.

Opposite:
Tobi-Ishi Outdoor, table • OT162

Nella pagina accanto:
Tobi-Ishi Outdoor, tavolo • OT162

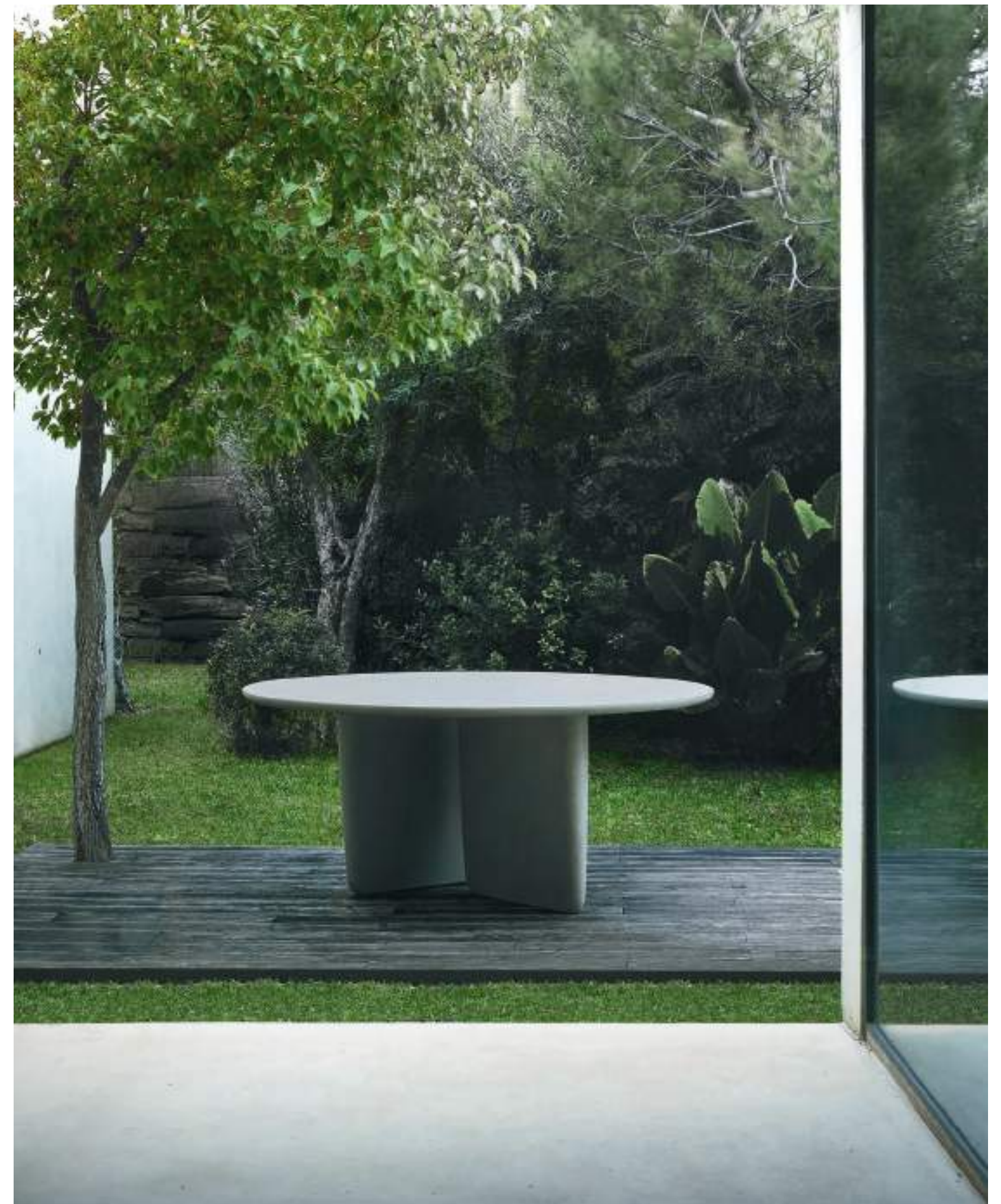

Link Outdoor

Jakob Wagner

It stands out for its “soft” material and sensual shape. The material makes you want to reach out and touch its smooth surface.

Si distingue per la sua matericità “morbida”, per la sensualità della sua forma e del suo materiale che suscitano il desiderio di sfiorarne la superficie levigata.





These pages and previous page:
Link Outdoor, table • TLK250N
White Collection, vase • AB20046B
*Mini Papilio Outdoor, chairs
*B&B Italia archive

In queste pagine e nella precedente:
Link Outdoor, tavolo • TLK250N
White Collection, vaso • AB20046B
*Mini Papilio Outdoor, sedie
*Archivio B&B Italia

Cosmos Outdoor

Jeffrey Bennett

A series of compact, streamlined tables which can be used individually or clustered together. Suitable both for public and residential spaces.

Serie di tavoli dalle linee armoniose che possono essere utilizzati in coppia o in piccoli gruppi. Ideali sia in spazi pubblici che residenziali.

Opposite:
Cosmos Outdoor, table • OTC90R_1

Nella pagina accanto:
Cosmos Outdoor, tavolo • OTC90R_1



Pushpam

Naoto Fukasawa

“I have called my latest project Pushpam, or flower in Indonesian, because the Papilio Shell chairs sit around these tables like butterflies flying around a flower”.
Naoto Fukasawa

“Ho chiamato questo nuovo tavolo Pushpam (fiore in indonesiano) perché è un tavolo a cui le Papilio Shell stanno intorno come le farfalle volano intorno al fiore”.
Naoto Fukasawa

Opposite:
Pushpam, table • TF100RA
Papilio Shell Outdoor, chairs • OSH1
Fat-Sofa Outdoor, ottoman • FA61P

Nella pagina accanto:
Pushpam, tavolo • TF100RA
Papilio Shell Outdoor, sedie • OSH1
Fat-Sofa Outdoor, pouf • FA61P



Papilio Shell Outdoor

Naoto Fukasawa

A chair characterised by a shell whose design evokes the Papilio butterfly. Comfort is ensured thanks to its cocooning wings.

Una sedia originata da una scocca, il cui schienale evoca formalmente le ali di una farfalla che accoglie comodamente ed abbraccia l'ospite.

Opposite:
Papilio Shell Outdoor, chairs • OSH1
Pushpam, table • TF100RA

Nella pagina accanto:
Papilio Shell Outdoor, sedie • OSH1
Pushpam, tavolo • TF100RA



Husk Outdoor

Patricia Urquiola

A collection of armchairs and chairs with an original personality characterized by soft and cosy cushions divided into small sections evoking relaxation at first sight.

Una serie di poltrone e sedie dalla personalità originale caratterizzata da una soffice e avvolgente cuscineria suddivisa in porzioni che invita al relax già al primo sguardo.



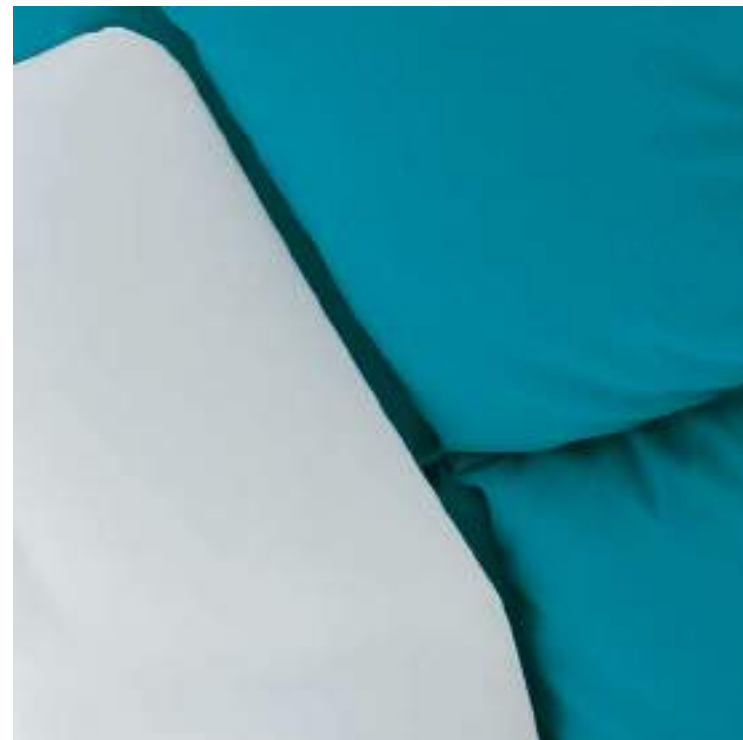

Previous page:
 Husk Outdoor, armchairs • H4 • H2
 Husk Outdoor, small table • HT

Opposite:
 Husk Outdoor, small table • HT062
 Butterfly, modular sofa
 Twist, carpet • TW300

Nella pagina precedente:
 Husk Outdoor, poltrone • H4 • H2
 Husk Outdoor, tavolino • HT

Nella pagina accanto:
 Husk Outdoor, tavolino • HT062
 Butterfly, divano componibile
 Twist, tappeto • TW300

Spool Outdoor

Piero Lissoni

An extremely versatile outdoor accessory able to add character to the setting thanks to its lively distinctive form.

Un complemento estremamente versatile in grado di conferire carattere agli ambienti grazie alla vivace proposta cromatica.

Opposite:
Spool Outdoor, small table • OS40T
Borea, sofa • BE243

Nella pagina accanto:
Spool Outdoor, tavolino • OS40T
Borea, divano • BE243



Tramae

unPIZZO

A three dimensional ottoman with a strong personality, thanks to its colourful weave that reinterprets tradition basket weaving giving it a new contemporary twist.

Un pouf in tre dimensioni con una forte personalità colorata che reinterpreta il tradizionale intreccio dei cesti in vimini in chiave contemporanea.

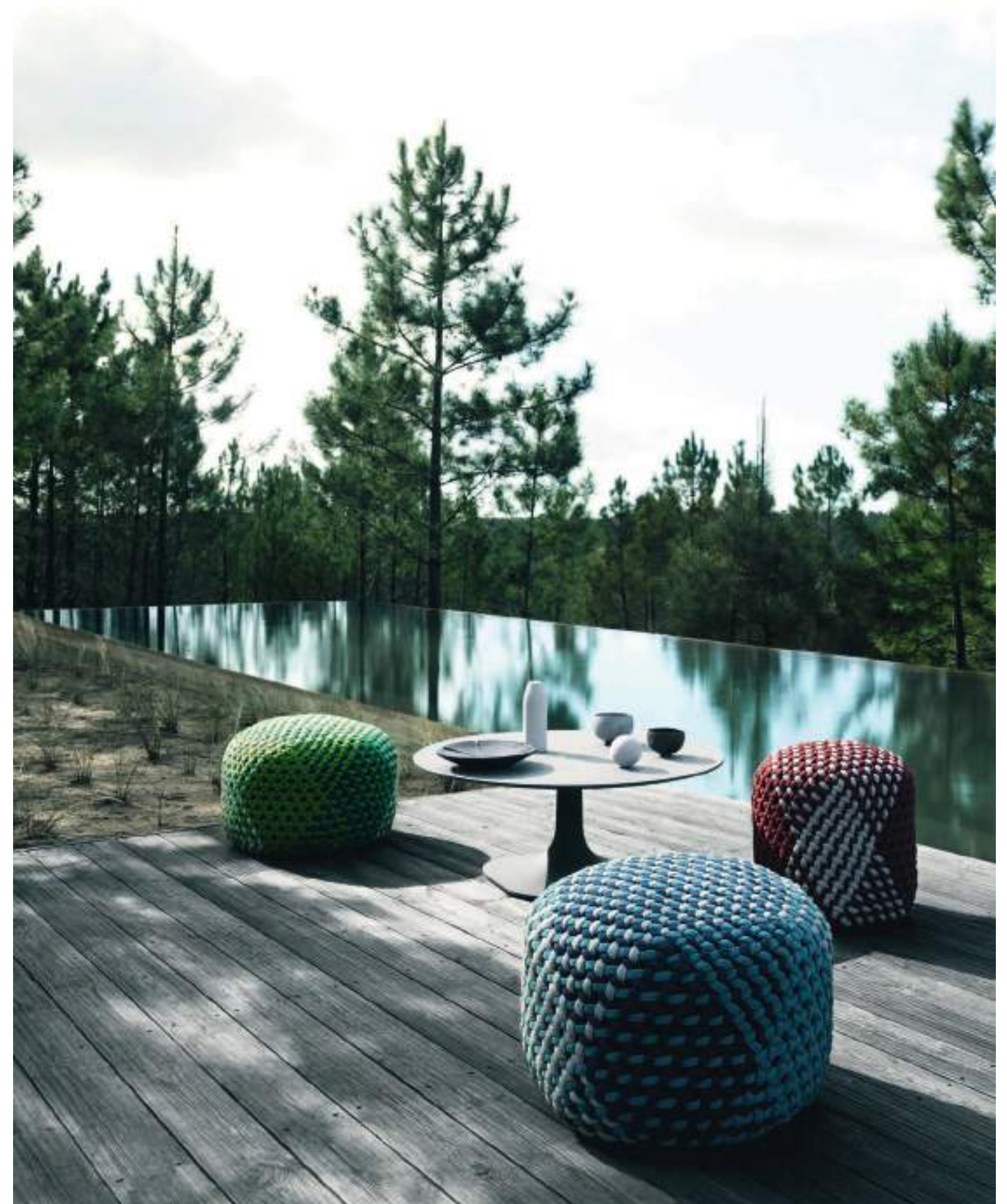

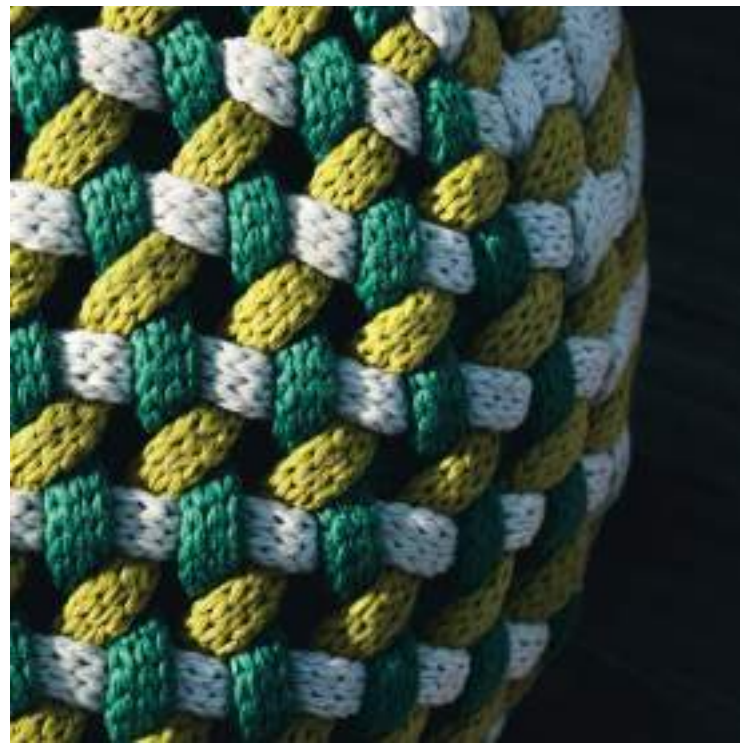

Previous and opposite page:
 Tramae, ottomans • TRM47P • TRM60P • TRM90P
 Pushpam, small table • TF100RB

Nella pagina accanto e nella precedente:
 Tramae, pouf • TRM47P • TRM60P • TRM90P
 Pushpam, tavolino • TF100RB

Hospes

B&B Italia CR&S

A versatile ottoman in two sizes that can be used in many ways and fits perfectly with different product families.

Un pouf versatile e dinamico in due dimensioni che si adatta a varie situazioni e a diverse famiglie di prodotto.



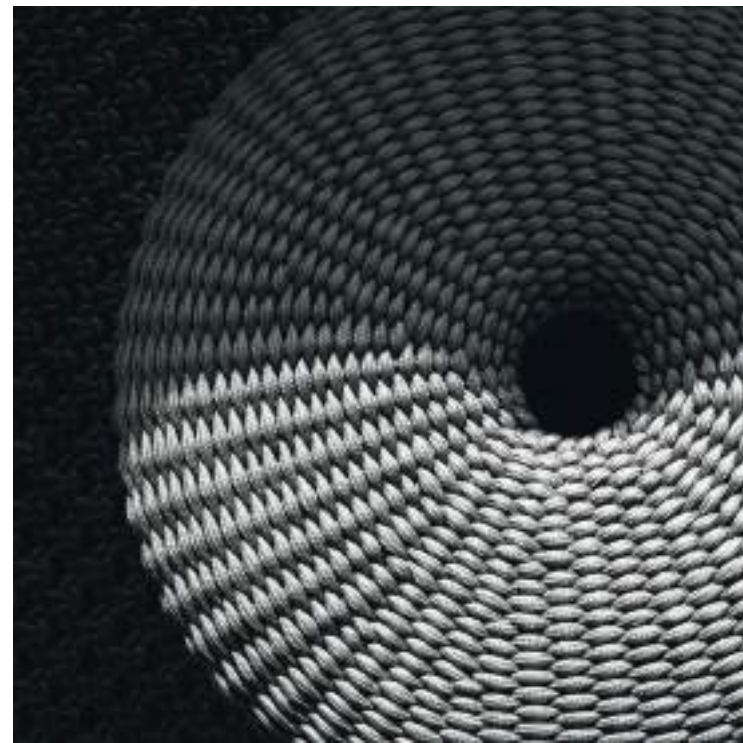

Previous and opposite page:
Hospes, ottomans • HE1 • HE2

Nella pagina accanto e nella precedente:
Hospes, pouf • HE1 • HE2



Colosseo Outdoor

Naoto Fukasawa

Colosseo debuts outdoor in a porcelain stoneware version. A furniture element with various functions depending on the setting.

Colosseo debutta outdoor nella nuova versione in gres porcellanato. Elemento di arredo con varie funzioni a seconda delle occasioni e delle necessità.

Opposite:
Colosseo, service elements • OCL40T • OCL45T

Nella pagina accanto:
Colosseo, elementi di servizio • OCL40T • OCL45T



Fat-Fat Outdoor

Patricia Urquiola

The concept of a tray helped create three small outdoor tables with steel frames that give them a lightweight look. These small tables are entirely painted or with tops in porcelain stoneware.

Il tema del vassoio viene ripreso per dar vita a tre tavolini per esterni il cui aspetto leggero è merito della struttura in acciaio. I tavolini sono proposti interamente verniciati oppure con piano in gres porcellanato.

Opposite:
Fat-Fat Outdoor, small tables • OTF92
Erica, sofa • E216
Erica, armchair • E80P

Nella pagina accanto:
Fat-Fat Outdoor, tavolini • OTF92
Erica, divano • E216
Erica, poltrona • E80P

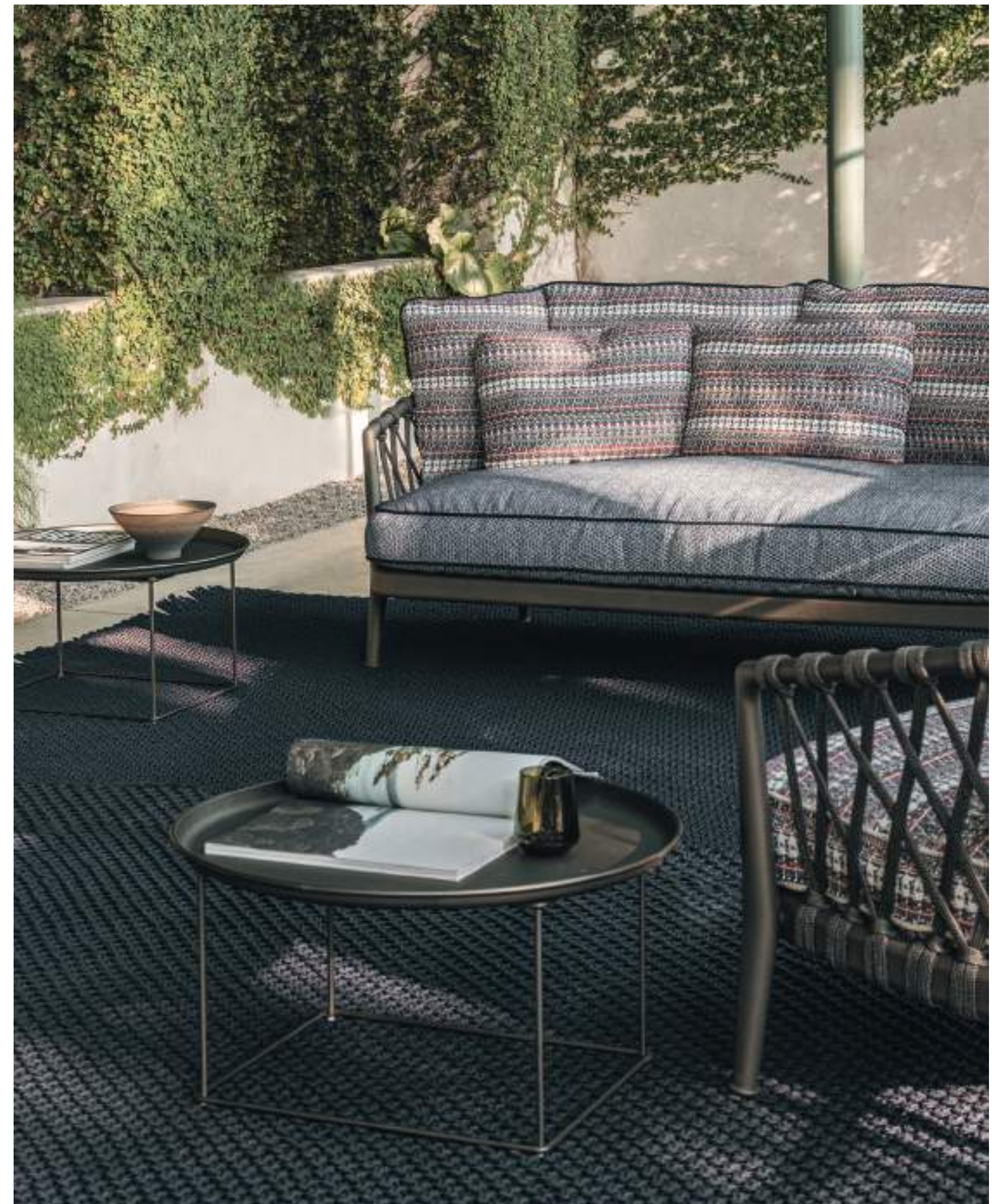

Awa Outdoor

Naoto Fukasawa

Base and top are integrated: aesthetically, it's the epitome of essential elegance.

Base e piano sono un unicuum: l'estetica si divide tra l'eleganza e l'essenzialità.

Opposite:
Awa Outdoor, small table • TA1
Butterfly, modular sofa • BT112D • BT112S

Nella pagina accanto:
Awa Outdoor, tavolino • TA1
Butterfly, divano componibile • BT112D • BT112S



Titikaka

Naoto Fukasawa

It revolutionises the concept of a bench. The traditional typology of the outdoor bench is revamped with contemporary language. It's an impressive piece that resembles a sculpture.

Rivoluziona il concetto di panchina. Ripropone la tradizionale tipologia della panca per esterni con linguaggio contemporaneo e si impone per la sua presenza scultorea.

Opposite:
Titikaka, bench • TK

Nella pagina accanto:
Titikaka, panca • TK



Overscale Flames Outdoor

Jean-Marie Massaud

The large oil candles designed by Jean-Marie Massaud are enclosed by a metallic frame painted matt white.

Le grandi candele a olio disegnate da Jean-Marie Massaud sono sostenute da una struttura metallica verniciata bianca opaca.

Opposite:
Overscale, candles • AB20044B

Nella pagina accanto:
Overscale, candele • AB20044B

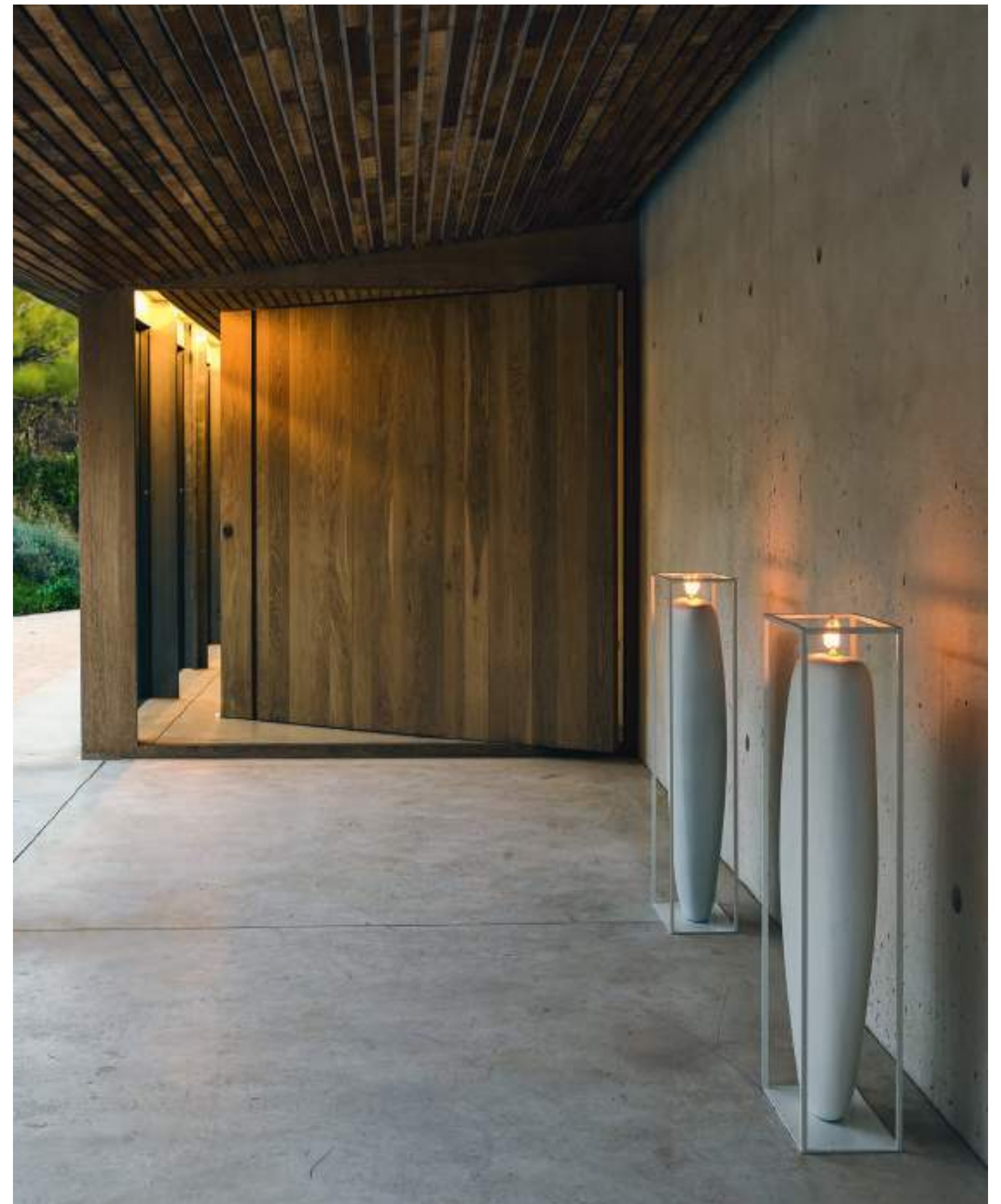

White Collection

Marcel Wanders

The Gold Collection by Marcel Wanders is available in the white version: vases and stool are in ceramic, also suitable for outdoor use.

La Gold Collection firmata da Marcel Wanders viene proposta in versione bianca: vasi e sgabello sono in ceramica, adatta anche per esterno.

Opposite:
White Collection, vases • AB20046B

Nella pagina accanto:
White Collection, vasi • AB20046B



Springtime

Jean-Marie Massaud

The Springtime complements are designed by Jean-Marie Massaud as furnishing elements of an outdoor area that conceptually dialogues between nature and interior spaces.

I complementi Springtime sono pensati da Jean-Marie Massaud come elementi di arredo di un'area esterna che dialoga concettualmente tra natura e spazi interni della casa.

Opposite:
Springtime, small tables • TST4 • TST7

Nella pagina accanto:
Springtime, tavolini • TST4 • TST7



Frank Outdoor

Antonio Citterio

This outdoor ottomans have contrasting profiles matched to colourful outdoor fabrics to provide a touch of colour to the outdoor furnishings.

Pouf per esterni che si caratterizzano per l'abbinamento di profili a contrasto abbinati a colorati tessuti outdoor che donano una nota di colore agli arredi per esterno.

Opposite:
Frank Outdoor, ottomans • OF58P

Nella pagina accanto:
Frank Outdoor, pouf • OF58P



Karam

B&B Italia CR&S

A collection of exotically inspired bowls and baskets that offer a practical answer to the pleasure of outdoor living.

Serie di ceste e ciotole di ispirazione esotica, offrono una risposta pratica al piacere di vivere all'aria aperta.

Opposite:
Karam, floor basket • KA02

Nella pagina accanto:
Karam, ceste da terra • KA02



Kyra

B&B Italia CR&S

Designed to guarantee high performance outdoor, Kyra carpets are made entirely by hand in a single size and they come in different colours.

Progettati per garantire alte prestazioni in ambienti esterni, i tappeti Kyra sono realizzati interamente a mano in una unica dimensione e sono proposti in diverse tonalità di colori.

Opposite:
Kyra, carpets • TY200

Nella pagina accanto:
Kyra, tappeti • TY200



Piet

B&B Italia CR&S

An homage to the painter Piet Mondrian who inspired the geometric lined pattern that decorates the carpet.

Un omaggio al pittore Piet Mondrian che ha ispirato il disegno geometrico delle linee che decorano il tappeto.

Opposite:
Piet, carpets • TPI300

Nella pagina accanto:
Piet, tappeti • TPI300



Twist Kaleidos

B&B Italia CR&S

Specifically designed for outdoor use, marked by permeability and breathability.

Studiati appositamente per l'utilizzo all'aperto con caratteristiche di permeabilità e traspirabilità.

Opposite:
Twist, carpets • TW200 • TW300
Kaleidos, carpet • TKA300

Nella pagina accanto:
Twist, tappeti • TW200 • TW300
Kaleidos, tappeto • TKA300

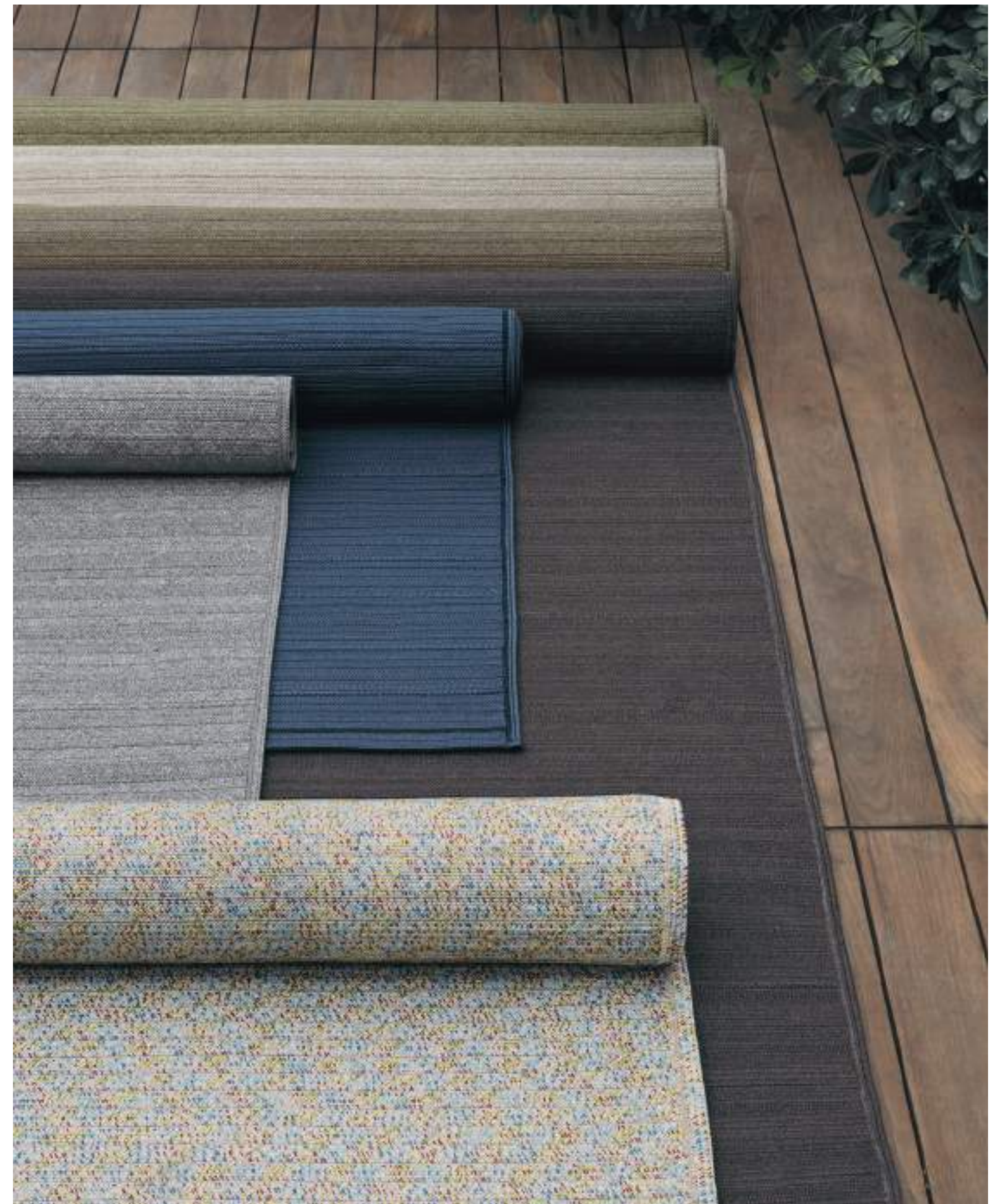

Sofas
Divani



Ayana
Naoto Fukasawa

Specifications 16

Inspiration 50



Bay
Nipa Doshi and Jonathan Levien

Specifications 26

Inspiration 170



Erica '19
Antonio Citterio

Specifications 90

Inspiration 106



Erica '19
Antonio Citterio

Specifications 90

Inspiration 106



Bay
Nipa Doshi and Jonathan Levien

Specifications 26

Inspiration 170



Borea
Piero Lissoni

Specifications 34

Inspiration 22



Fat-Sofa Outdoor
Patricia Urquiola

Specifications 100

Inspiration 192



Fat-Sofa Outdoor
Patricia Urquiola

Specifications 100

Inspiration 192



Canasta
Patricia Urquiola

Specifications 56

Inspiration 204



Canasta
Patricia Urquiola

Specifications 56

Inspiration 204



Gio
Antonio Citterio

Specifications 114

Inspiration 148



Hybrid
Antonio Citterio

Specifications 132

Inspiration 63



Canasta '13
Patricia Urquiola

Specifications 66

Inspiration 198



Canasta '13
Patricia Urquiola

Specifications 66

Inspiration 198



Oh, it rains!
Philippe Starck

Specifications 170

Inspiration 74



Pablo Outdoor
Vincent Van Duysen

Specifications 176

Inspiration 4



Canasta
Patricia Urquiola

Specifications 56

Inspiration 204



Canasta '13
Patricia Urquiola

Specifications 56

Inspiration 204



Ray Outdoor Fabric
Antonio Citterio

Specifications 196

Inspiration 138



Ray Outdoor Natural
Antonio Citterio

Specifications 202

Inspiration 146



Charles Outdoor
Antonio Citterio

Specifications 72

Inspiration 158



Erica
Antonio Citterio

Specifications 86

Inspiration 116



Ribes
Antonio Citterio

Specifications 210

Inspiration 86



Ribes
Antonio Citterio

Specifications 210

Inspiration 86

Modular sofas
Divani componibili



Butterfly
Patricia Urquiola

Specifications 52

Inspiration 184



Charles Outdoor
Antonio Citterio

Specifications 72

Inspiration 158



Gio
Antonio Citterio

Specifications 114

Inspiration 148



Hybrid
Antonio Citterio

Specifications 132

Inspiration 63



Ray Outdoor Fabric
Antonio Citterio

Specifications 196

Inspiration 138



Ray Outdoor Natural
Antonio Citterio

Specifications 202

Inspiration 146



Ray Outdoor Natural
Antonio Citterio

Specifications 202

Inspiration 146



Ribes
Antonio Citterio

Specifications 210

Inspiration 86



Ribes
Antonio Citterio

Specifications 210

Inspiration 86

Chaise Longue
Chaise Longue



Hybrid
Antonio Citterio

Specifications 132

Inspiration 63



Ray Outdoor Fabric
Antonio Citterio

Specifications 196

Inspiration 138



Ray Outdoor Natural
Antonio Citterio

Specifications 202

Inspiration 146



Ray Outdoor Natural
Antonio Citterio

Specifications 202

Inspiration 146



Ribes
Antonio Citterio

Specifications 210

Inspiration 86

Sunbeds
Lettini



Borea
Piero Lissoni

Specifications 234

Inspiration 22



Borea
Piero Lissoni

Specifications 34

Inspiration 22



Gio
Antonio Citterio

Specifications 114

Inspiration 148



Mirto Outdoor
Antonio Citterio

Specifications 150

Inspiration 120



Mirto Outdoor
Antonio Citterio

Specifications 150

Inspiration 120



Ray Outdoor Fabric
Antonio Citterio

Specifications 196

Inspiration 138

Armchairs and small armchairs Poltrone e poltroncine



Ayana
Naoto Fukasawa

Specifications 16

Inspiration 50



Bay
Nipa Doshi and Jonathan Levien

Specifications 26

Inspiration 170



Gio
Antonio Citterio

Specifications 114

Inspiration 148



Husk Outdoor
Patricia Urquiola

Specifications 126

Inspiration 230



Bay
Nipa Doshi and Jonathan Levien

Specifications 26

Inspiration 170



Borea
Piero Lissoni

Specifications 34

Inspiration 22



Mirto Outdoor
Antonio Citterio

Specifications 150

Inspiration 120



Oh, it rains!
Philippe Starck

Specifications 170

Inspiration 74



Borea
Piero Lissoni

Specifications 34

Inspiration 22



Canasta
Patricia Urquiola

Specifications 56

Inspiration 204



Pablo Outdoor
Vincent Van Duysen

Specifications 176

Inspiration 4



Ray Outdoor Fabric
Antonio Citterio

Specifications 196

Inspiration 138



Canasta '13
Patricia Urquiola

Specifications 66

Inspiration 198



Charles Outdoor
Antonio Citterio

Specifications 72

Inspiration 158



Ray Outdoor Natural
Antonio Citterio

Specifications 202

Inspiration 146



Ray Outdoor Natural
Antonio Citterio

Specifications 202

Inspiration 146



Crinoline
Patricia Urquiola

Specifications 82

Inspiration 212



Erica
Antonio Citterio

Specifications 86

Inspiration 116



Erica '19
Antonio Citterio

Specifications 90

Inspiration 106



Fat-Sofa Outdoor
Patricia Urquiola

Specifications 100

Inspiration 192

Ottomans
Pouf



Bay
Nipa Doshi and Jonathan Levien

Specifications 26

Inspiration 170



Frank Outdoor
Antonio Citterio

Specifications 104

Inspiration 258



Hospes
B&B Italia CR&S

Specifications 124

Inspiration 240



Pablo Outdoor
Vincent Van Duyen

Specifications 176

Inspiration 4



Tramae
unPIZZO

Specifications 236

Inspiration 236

Tables
Tavoli



Ayana
Naoto Fukasawa

Specifications 16

Inspiration 50



Fat-Sofa Outdoor
Patricia Urquiola

Specifications 100

Inspiration 192



Hybrid
Antonio Citterio

Specifications 132

Inspiration 63



Husk Outdoor
Patricia Urquiola

Specifications 126

Inspiration 230



Ribes
Antonio Citterio

Specifications 210

Inspiration 86



Borea
Piero Lissoni

Specifications 34

Inspiration 22

Tables
Tavoli



Canasta
Patricia Urquiola

Specifications 62

Inspiration 208



Ginepro
Antonio Citterio

Specifications 106

Inspiration 164



Ginestra
Antonio Citterio

Specifications 110

Inspiration 178



Gio
Antonio Citterio

Specifications 114

Inspiration 148



Mirto Outdoor
Antonio Citterio

Specifications 150

Inspiration 120



Pushpam
Naoto Fukasawa

Specifications 194

Inspiration 226



Cosmos Outdoor
Jeffrey Bernett

Specifications 80

Inspiration 224



Ginepro
Antonio Citterio

Specifications 106

Inspiration 164



Ginestra
Antonio Citterio

Specifications 110

Inspiration 178



Link Outdoor
Jakob Wagner

Specifications 148

Inspiration 220



Mirto Outdoor
Antonio Citterio

Specifications 150

Inspiration 120



Tobi-Ishi Outdoor
Edward Barber and Jay Osgerby

Specifications 234

Inspiration 218

Chairs
Sedie**Ayana**
Naoto Fukasawa

Specifications 16

Inspiration 50

**Canasta '13**
Patricia Urquiola

Specifications 66

Inspiration 198

**Erica**
Antonio Citterio

Specifications 86

Inspiration 116

**Ginestra**
Antonio Citterio

Specifications 26

Inspiration 170

**Husk Outdoor**
Patricia Urquiola

Specifications 126

Inspiration 230

**Papilio Shell Outdoor**
Naoto Fukasawa

Specifications 190

Inspiration 228

**Borea**
Piero Lissoni

Specifications 34

Inspiration 22

**Crinoline**
Patricia Urquiola

Specifications 34

Inspiration 22

**Erica '19**
Antonio Citterio

Specifications 90

Inspiration 106

**Gio**
Antonio Citterio

Specifications 34

Inspiration 22

**Mirto Outdoor**
Antonio Citterio

Specifications 150

Inspiration 120

Low tables, small tables and service elements
Tavoli bassi, tavolini ed elementi di servizio**Awa Outdoor**
Naoto Fukasawa

Specifications 14

Inspiration 248

**Borea**
Piero Lissoni

Specifications 34

Inspiration 22

**Canasta**
Patricia Urquiola

Specifications 62

Inspiration 208

**Canasta '13**
Patricia Urquiola

Specifications 66

Inspiration 198

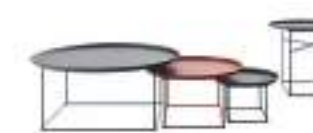
**Fat-Fat Outdoor**
Patricia Urquiola

Specifications 98

Inspiration 246

**Husk Outdoor**
Patricia Urquiola

Specifications 126

Inspiration 230

**Ayana**
Naoto Fukasawa

Specifications 16

Inspiration 50

**Butterfly**
Patricia Urquiola

Specifications 52

Inspiration 184

**Canasta**
Patricia Urquiola

Specifications 56

Inspiration 204

**Canasta '13**
Patricia Urquiola

Specifications 66

Inspiration 198

**Gio**
Antonio Citterio

Specifications 114

Inspiration 148

**Mirto Outdoor**
Antonio Citterio

Specifications 150

Inspiration 120

Low tables and small tables
Tavoli bassi e tavolini



Mirto Outdoor
Antonio Citterio

Specifications 150

Inspiration 120



Pablo Outdoor
Vincent Van Duysen

Specifications 176

Inspiration 4



Tobi-Ishi Outdoor
Edward Barber and Jay Osgerby

Specifications 234

Inspiration 218

Benches
Panche



Gio
Antonio Citterio

Specifications 114

Inspiration 148



Ribes
Antonio Citterio

Specifications 210

Inspiration 86



Pablo Outdoor
Vincent Van Duysen

Specifications 176

Inspiration 4



Pushpam
Naoto Fukasawa

Specifications 194

Inspiration 226



Spool Outdoor
Piero Lissoni

Specifications 228

Inspiration 234



Hybrid
Antonio Citterio

Specifications 132

Inspiration 63



Titikaka
Naoto Fukasawa

Specifications 232

Inspiration 250

Complements
Complementi



Colosseo Outdoor
Naoto Fukasawa

Specifications 78

Inspiration 244



Overscale Flames Outdoor
Jean-Marie Massaud

Specifications 174

Inspiration 252



White Collection
Marcel Wanders

Specifications 240

Inspiration 254



Karam
B&B Italia CR&S

Specifications 26

Inspiration 170



Springtime
Jean-Marie Massaud

Specifications 230

Inspiration 256

Carpets
Tappeti



Kaleidos
B&B Italia CR&S

Specifications 142

Inspiration 266



Kyra
B&B Italia CR&S

Specifications 146

Inspiration 262



Piet
B&B Italia CR&S

Specifications 192

Inspiration 264



Twist
B&B Italia CR&S

Specifications 238

Inspiration 266

Awa Outdoor

Naoto Fukasawa • 2009

Inspiration • 248



A sculptural project by Naoto Fukasawa: the small table Awa Outdoor is a versatile object that can be used as a base for a lot of things. Base and top are integrated: aesthetically, it's the epitome of essential elegance. Awa is made with a technologically advanced material, a special blend of white Cristalplant Outdoor® that ensures it can be used both indoors and outdoors. Its particular surface is very soft, similar to natural stone.

Scultoreo progetto di Naoto Fukasawa: il tavolino Awa Outdoor è un oggetto versatile, di servizio, indispensabile per l'appoggio. Base e piano sono un unicuum: l'estetica si divide tra l'eleganza e l'essenzialità. Il materiale è tecnologicamente avanzato: lo compone una speciale miscela in Cristalplant Outdoor® bianco che assicura l'utilizzo in indoor così come in outdoor. La particolare superficie del materiale ha un effetto soft touch, simile alla pietra naturale.

Top and base-frame	Cristalplant Outdoor® (natural mineral filler of phosphate of aluminium with polyester acrylate resin)	Piano e basamento	Cristalplant Outdoor® (carica minerale naturale di idrato d'alluminio con resina poliestere acrilata)
Ferrules	thermoplastic material	Puntali	materiale termoplastico

Small table

Tavolino

TA1

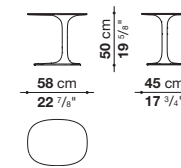

Top and base-frame

Piano e basamento

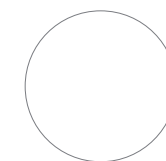

0101G
white Cristalplant Outdoor®
Cristalplant Outdoor® bianco

The colour shown are an indication.
La tonalità del colore è indicativa.

Ayana

Naoto Fukasawa • 2020

Inspiration • 50



Minimalist and innovative, the Ayana collection becomes a new chapter in the story that connects B&B Italia to Naoto Fukasawa. It sees wood as the protagonist, interpreted in an unusual way, with a pleasant oriental touch. If the depths and heights are a clear reference to the south-east Asian tradition, the backrest recalls a Swedish wall bar, an exercise equipment turned into a load-bearing element. Thanks to this solution, the elements of the Ayana collection can be enjoyed and appreciated at 360 degrees, discovering on each side a new elegant interplay of intersections and proportions. Two and three seat sofas and the armchair have armrests at different heights. The armchair armrest is higher to guarantee a more ergonomic seat. The sofa armrest, which is lower, can be combined with a cushion that is easy to be fastened and removed, and helps to lie down more comfortably if necessary. The upholstery of this collection stands out for the individual cushions, all covered with waterproof fabrics.

Minimalista e innovativa, la collezione Ayana diventa un nuovo capitolo nella storia che lega B&B Italia a Naoto Fukasawa e che vede come protagonista il legno, interpretato in maniera insolita, con un piacevole tocco orientale. Se le profondità e le altezze sono un chiaro rimando alla tradizione del sud-est asiatico, lo schienale richiama una spalliera svedese, che da strumento per l'attività fisica si trasforma in elemento portante. Grazie a questa soluzione, gli elementi della collezione Ayana possono essere goduti e apprezzati a 360 gradi, scoprendo su ogni lato un nuovo elegante gioco di incroci e proporzioni. I divani, proposti nelle versioni a due e tre posti, e la poltrona si presentano con braccioli di diversa altezza. Il bracciolo della poltrona è più alto per garantire una seduta più ergonomica. Al bracciolo del divano, più basso, è possibile abbinare un cuscinetto facile da agganciare e rimuovere, che all'occorrenza consente di sdraiarsi agevolmente. Le imbottiture si contraddistinguono per i cuscini singoli, rivestiti da tessuti waterproof.



Ayana's warm minimalism is completed with a chair, a dining table and a low table. The dining chair recalls the stylistic features of the other seats, for a perfect family feeling, with the structure in natural teak wood and two generously padded cushions covered in fabric. The table stands out for its oval top in serpentine, a typical stone of the Alps. The supporting structure in natural teak appears light but is extremely robust, able to resist weather and support the heavy top. Even the coffee table has a round section structure in natural teak, with a top in serpentine. Its broad dimensions allow to create a pleasant convivial atmosphere in outdoor settings. Ayana is a project with a green soul. The teak used to make the structures is FSC® certified (Forest Stewardship Council) and all the materials that make up the various elements of the series, at the end of the product's life cycle, can be separated and disposed of with respect for the environment.

Il minimalismo caldo di Ayana si completa con una sedia, un tavolo da pranzo e un tavolo basso. La sedia richiama gli stilemi delle altre sedute, per un perfetto family feeling, con la struttura in teak naturale a sezione tonda e una generosa imbottitura a due cuscini rivestiti in tessuto. Il tavolo si contraddistingue per l'ovale del piano in serpentino, pietra tipica delle Alpi. La struttura portante in teak naturale appare leggera ma si rivela estremamente robusta, capace di resistere alle intemperie e sostenere l'importante superficie. Anche il tavolo basso presenta la struttura a sezione tonda in teak naturale, sormontata da un piano in serpentino. Le ampie dimensioni sono pensate per creare un ambiente conviviale e piacevole anche all'aperto. Ayana è un progetto dall'animo green. Il teak utilizzato per realizzare le strutture è certificato FSC® (Forest Stewardship Council) e tutti i materiali che compongono i vari elementi della serie, al termine del ciclo di vita del prodotto, potranno essere separati e smaltiti nel rispetto dell'ambiente.

Ayana

Naoto Fukasawa • 2020

Inspiration • 50

The entire collection is based on structures with a round section, a far cry from the traditional square section that defines many outdoor furnishings. As if they were made of sticks simply set next to one another, the Ayana structures are made of natural teak. The wood is unpainted to allow it to age and evolve in the most genuine way, respecting the intrinsic characteristics of this material. An ancestral choice that recalls ancient tools and primitive constructions, which however conceals ingenious technical solutions. The structures are also distinguished by the presence of invisible joints that do not include metal elements such as screws, but only wooden pins. An aesthetic choice that is also a functional one: in fact, this allows the wood to continue its transformations as weather conditions change, without however causing irreversible cracking or deformation. In Fukasawa's vision, round sections and untreated wood create a more natural look that is completed with a seat style that is halfway between the Far East and contemporary Scandinavian.

L'intera collezione si basa su strutture a sezione tonda, lontane dalla tradizionale sezione quadrata che definisce larga parte dell'arredo outdoor. Come fossero fatte di bastoni semplicemente accostati, appoggiati a quota zero, le strutture di Ayana sono realizzate in teak naturale, non verniciato in modo da garantire al legno di maturare ed evolvere nella maniera più genuina, rispettando le caratteristiche intrinseche di questo materiale. Una scelta ancestrale, che ricorda strumenti antichi o magari costruzioni primitive, che tuttavia nasconde soluzioni tecniche di assoluto ingegno. Le strutture sono contraddistinte anche dalla presenza di incastri invisibili che non prevedono l'aggiunta di elementi metallici quali viti o giunti, ma soltanto spine di legno. Una scelta estetica, ma anche funzionale: infatti in questo modo si permette al legno di seguire naturalmente le sue trasformazioni al variare delle condizioni atmosferiche, senza però causare fessurazioni o deformazioni irreversibili. Nella visione di Fukasawa, sezione tonda e legno non trattato concorrono a creare un aspetto più naturale, che si completa con uno stile di seduta che si situa a metà strada tra Estremo Oriente e contemporaneo scandinavo.



Ayana Naoto Fukasawa • 2020

Inspiration • 50

TEAK WOOD

Teak wood comes from various tectona plants that are common in tropical countries. As a result of its strong resistance to humidity and of its internal content of oily substances, it is considered a very precious wood type especially for outdoor environments.

It must be said that wood is a living material that reacts to external agents; hence, it is normal and natural to note a variation in the shade of colour as time goes by. The change in colour over time is not a defect.

On the contrary, it is a natural characteristic of this wood that lives and reacts to the outside environment with an aging/oxidation process which does not alter the structural integrity of the product. The images on the right show an example of how the colour of the wood surface can vary.

Il legno di Teak proviene da diverse piante di tectona diffuse nei paesi tropicali. Ha eccellenti caratteristiche di resistenza agli agenti atmosferici, alla salsedine, all'umidità e alle escursioni termiche grazie alla presenza al suo interno di una resina oleosa. Il legno è comunque un materiale vivo che reagisce agli agenti esterni; una esposizione continua ad essi muta progressivamente lo strato superficiale fino alla formazione di una patina superficiale grigio/argento. Tale fenomeno non è quindi da considerarsi un difetto ma la testimonianza della naturalità del legno che vive e reagisce all'ambiente esterno con un processo di maturazione/ossidazione che non altera in alcun modo l'integrità strutturale del prodotto. L'immagine a lato riporta un esempio di variazione della colorazione della superficie del legno.

SERPENTINE STONE

The Serpentine of Valmalenco is an ornamental stone used for both construction and furnishing. It is quarried by natural splitting or in blocks and has physical and aesthetic properties that render it both highly prized and extremely durable. Thanks to its physical and aesthetic properties, it is perfect for interior and exterior cladding of buildings, lining stoves and furnishings. With its fine grain and marked foliation, natural split serpentine is processed mainly into sheets of varying thicknesses.

Il serpentino della Valmalenco è una pietra ornamentale e da costruzione utilizzata in edilizia e nell'arredamento. E' coltivato sia nella varietà a spacco sia in quella massiccia, e possiede caratteristiche fisiche ed estetiche che lo rendono estremamente durevole e pregiato. Grazie alle sue proprietà fisiche e qualità estetiche, trova naturale impiego nella realizzazione di rivestimenti di stufe, esterni e interni di edifici e complementi d'arredo. Il serpentino a spacco, in virtù della sua grana molto fine e della marcata foliazione, viene lavorato prevalentemente in lastre di vario spessore, leggere e impermeabili.



2602407

Linaria

2485207

Lipari

2602207

Linaria

0408S

Serpentine stone

Pietra Serpetino

0456T

Natural teakwood

Teak naturale



Ayana

Naoto Fukasawa • 2020

Inspiration • 50

Sofas
Divani

AY210

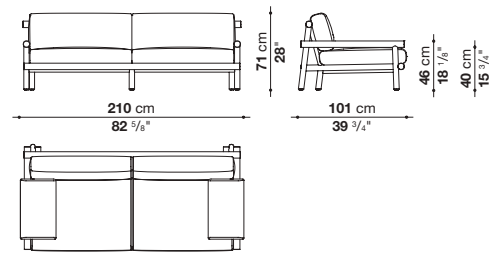

AY263

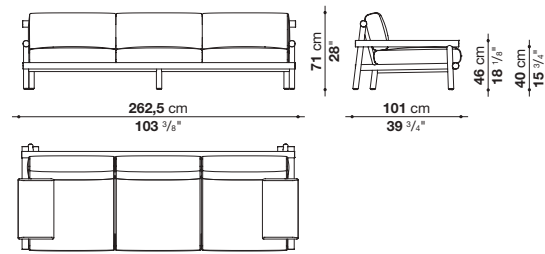

Armchair
Poltrona

AY86P

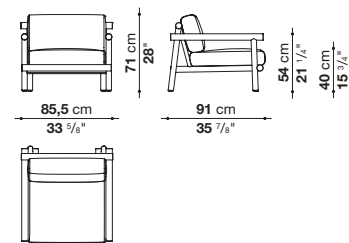

Chair
Sedia

AY58S

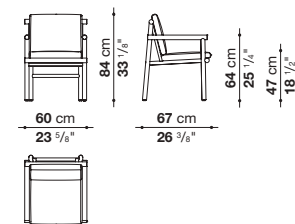
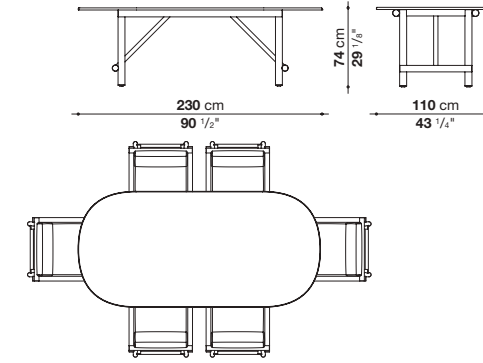

Table
Tavolo

TAY230



Low table
Tavolo basso

TAY180

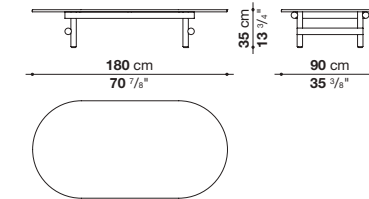

Ayana

Naoto Fukasawa • 2020

Inspiration • 50

Frame	solid wood
Upholstery	shaped polyurethane, cover in water repellent polyester fibre
Top (TAY230-TAY180)	Serpentine stone
Ferrules	thermoplastic material
Waterproof cover cloth	PES fabric coated on one side in PU
Cover	fabric in limited categories

Struttura	legno massello
Imbottitura	poliuretano sagomato, fodera in fibra di poliestere con trattamento idrorepellente
Piano (TAY230-TAY180)	pietra Serpentino
Puntali	materiale termoplastico
Telo di copertura impermeabile	tessuto PES monospalmato su un lato PU
Rivestimento	tessuto in categorie limitate

Frame
Struttura



0456T
natural teakwood
teak naturale

Table and low table top
Piano tavolo e tavolo basso

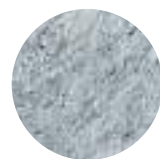

0408S
Serpentine stone
pietra Serpentino

The colours and materials shown are an indication. Images not in scale.
La tonalità dei colori e dei materiali è indicativa. Immagini non in scala.

Product items/Prodotti
Recommended combinations/Abbinamenti suggeriti



2602207
Linaria



2485207
Lipari



0456T
natural teakwood
teak naturale



2603207
Liri



0456T
natural teakwood
teak naturale



2485207
Lipari



0456T
natural teakwood
teak naturale



2485407
Lipari



0456T
natural teakwood
teak naturale



2485830
Lipari



0456T
natural teakwood
teak naturale



2485830
Lipari



0408S
Serpentine
stone
pietra
Serpentino



0456T
natural teakwood
teak naturale

The colours and materials shown are an indication. Images not in scale.
La tonalità dei colori e dei materiali è indicativa. Immagini non in scala.

Bay

Nipa Doshi and Jonathan Levien • 2018
Inspiration • 170



Bay is a collection of sculptural and monolithic yet visually light outdoor seats comprising of a sofa in two sizes, an armchair and a high-backed armchair. Their enveloping volumes are marked by a double polypropylene fibre interlacing that creates “air pockets”, granting transparency and lightness to the furniture. The frame accommodates padded solid seats and soft cushions for added comfort. The colours combinations are extremely refined, with tortora and anthracite for the interlacing, paired with elegant block colour and patterned fabrics for the seats and cushions.

Bay è una collezione di sedute da esterno composta da divano in due dimensioni, poltrona e poltrona con schienale alto, che si distinguono per l'aspetto scultoreo monolitico, al contempo visivamente leggero. Avvolgenti volumi intrecciati realizzati in fibra di polipropilene, con un doppio intreccio che crea “tasche d'aria” che donano trasparenza e leggerezza, sono combinati con sedute imbottite dalle sembianze di rocce e si completano con morbidi cuscini che offrono grande comfort. Ricercata la proposta cromatica che prevede due colori per l'intreccio, tortora e antracite, da abbinare alle raffinate tonalità di tessuti tinta unita e fantasia previsti per i rivestimenti di sedute e cuscini.

Bay

Nipa Doshi and Jonathan Levien • 2018
Inspiration • 170



In 2019 the Bay collection has seen the addition of a sofa, a small armchair and an ottoman that reinforce the iconic image of the range by mirroring the generous and solid shapes and the sense of transparency generated by the interplay of anthracite-and dove-coloured polypropylene interlacing. The new sofa has a particularly welcoming and deep seat, complemented by soft seat-back cushions and new roller cushions that can be used as headrests. The small armchair is a scaled-down version of the existing armchair providing a perfect addition to the collection, or an alternative for smaller spaces. The new ottoman mirrors the chair design and coordinates with the whole range.

La collezione Bay si arricchisce nel 2019 di un divano, una poltroncina e un pouf che confermano l'iconicità della famiglia, riprendendone i volumi ampi e monolitici e le trasparenze create dai sofisticati giochi di intrecci in polipropilene antracite e tortora. Il nuovo divano presenta una seduta particolarmente accogliente e profonda, completata da morbidi cuscini schienale e dai nuovi cuscini rullo da utilizzare come poggiatesta. La poltroncina riproduce in scala ridotta le poltrone già in collezione, diventando così una perfetta aggiunta oppure un'alternativa per spazi più ridotti. Nuovo anche il pouf che riprende il disegno delle sedute e si coordina con tutti gli elementi della serie.



Bay

Nipa Doshi and Jonathan Levien • 2018

Inspiration • 170

Sofas
Divani

BY176

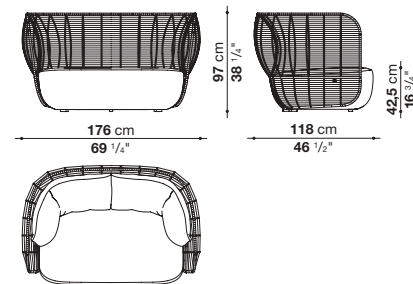

BY176CL

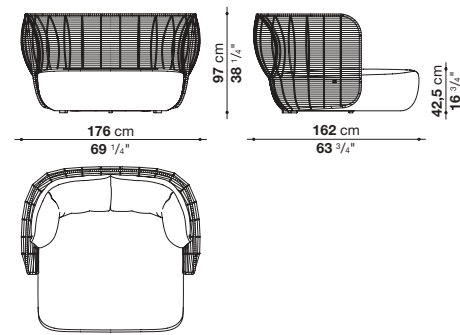

BY236

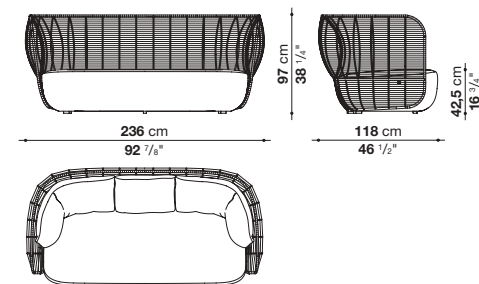

Small armchairs
Poltroncina

BY94N

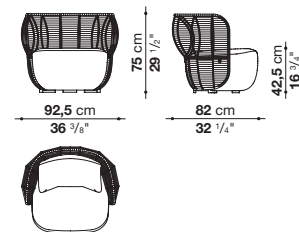

Armchairs
Poltrone

BY118B

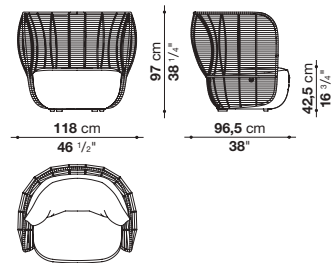

BY123A

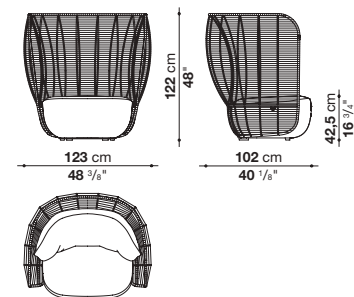

Ottoman
Pouf

BY74PQ

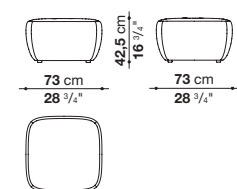

Internal frame	tubular steel and steel profiles	Telaio interno	tubolari e profilati d'acciaio
Back frame	aluminium	Telaio schienale	alluminio
Upholstery	Bayfit® (Bayer®) flexible cold shaped polyurethane foam, water repellent polyester fibre cover (with heat-sealed ribbon)	Imbottitura	schiuma di poliuretano flessibile a freddo Bayfit® (Bayer®), fodera in fibra di poliestere con trattamento idrorepellente (con cuciture termosaldate)
Back cushion	Solotex fibre and visco-elastic polyurethane combination, cover in water repellent polyester fibre	Cuscino schienale	combinazione fibra Solotex e poliuretano viscoelastico, fodera in fibra di poliestere con trattamento idrorepellente
Interlacing	polypropylene fibre braid	Intreccio	treccia in fibra di polipropilene
Feet and ferrules	thermoplastic material	Piedini e puntali	materiale termoplastico
Waterproof cover cloth	PES fabric coated on one side in PU	Telo di copertura impermeabile	tessuto PES monospalmato su un lato PU
Cover	fabric in limited categories	Rivestimento	tessuto in categorie limitate

Frame and interlacing matching
Abbinamento struttura e intreccio



0158A
anthracite painted - anthracite polypropylene
verniciato antracite - polipropilene antracite

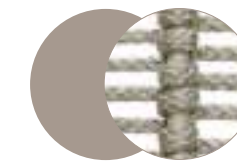

0833T
tortora painted - tortora polypropylene
verniciato tortora - polipropilene tortora

The colours and materials shown are an indication. Images not in scale.
La tonalità dei colori e dei materiali è indicativa. Immagini non in scala.

Bay
Nipa Doshi and Jonathan Levien • 2018
Inspiration • 170

2558877
Samos

2481877
Lesia

2481400
Lesia

2481251
Lesia

2481255
Lesia



The colours and materials shown are an indication. Images not in scale.
La tonalità dei colori e dei materiali è indicativa. Immagini non in scala.

Product items/Prodotti
Recommended combinations/Abbinamenti suggeriti



2481877
Lesia



2558877
Samos



0158A
anthracite painted
anthracite polypropylene
verniciato antracite
polipropilene antracite



2481877
Lesia



2558877
Samos



0158A
anthracite painted
anthracite polypropylene
verniciato antracite
polipropilene antracite



2481255
Lesia



2485255
Lipari



0158A
anthracite painted
anthracite polypropylene
verniciato antracite
polipropilene antracite



2481400
Lesia



2558877
Samos



0158A
anthracite painted
anthracite polypropylene
verniciato antracite
polipropilene antracite



2481280
Lesia



2570415
Elisir



2570420
Elisir



0833T
tortora painted
tortora polypropylene
verniciato tortora
polipropilene tortora



2481280
Lesia



2570420
Elisir



0833T
tortora painted
tortora polypropylene
verniciato tortora
polipropilene tortora

The colours and materials shown are an indication. Images not in scale.
La tonalità dei colori e dei materiali è indicativa. Immagini non in scala.

Borea

Piero Lissoni • 2021-2022

Inspiration • 22



Borea is a complete and eclectic collection of outdoor seats and tables designed by Piero Lissoni. The numerous pieces in the collection have in common tubular metal structures with a fluid and seamless design, without joints and interruptions, captivating and even emerging in the detail that extends to the base. The metal bending processes take advantage of techniques typically used in the aeronautical sector and transport them into the world of outdoor furniture bringing life to a collection with an unmistakable style.

Borea è una collezione completa ed eclettica di sedute e tavoli da esterni disegnata da Piero Lissoni. I numerosi pezzi che la compongono sono accomunati da strutture in metallo tubolare dal disegno fluido e continuo, senza giunti e interruzioni, accattivante e addirittura sorprendente nella parte terminale che appoggia a terra. Le lavorazioni di piegatura e curvatura del metallo riprendono tecniche tipicamente utilizzate nel settore aeronautico e le trasportano nel mondo dell'arredo outdoor dando vita ad una collezione dalla cifra stilistica inconfondibile.

The collection includes two- and three-seater sofas, an oversized armchair, a low small armchair and a dining chair, all with stackable aluminum structures painted in dove grey, sage, clay and anthracite colours. Comfort is ensured by generous cushions, which are not only soft and relaxing but were also developed to be sustainable. Paddings are in fact made with polyester fiber filling coming from recycled PET plastic bottles enveloping a different densities polyurethane core.

Le sedute comprendono divani a due e tre posti, una poltrona dalle proporzioni importanti, una poltroncina bassa e una poltroncina pranzo, tutte con strutture impilabili in alluminio verniciato nei colori tortora, salvia, argilla e antracite. Il comfort è assicurato da cuscinate super generose e accoglienti, all'insegna della morbidezza, del relax e della sostenibilità. Le imbottiture sono infatti realizzate in fibra 100% poliestere proveniente dal riciclo di bottiglie in plastica PET che avvolge un inserto in poliuretano a densità differenziata.

Borea
Piero Lissoni • 2021-2022
Inspiration • 22

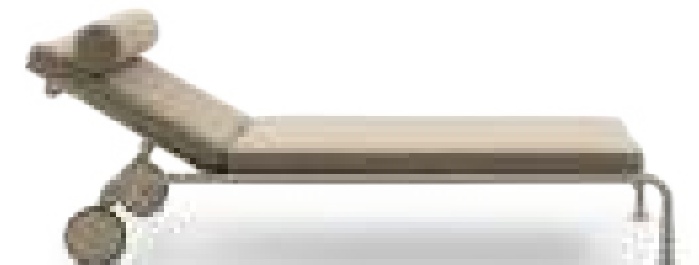
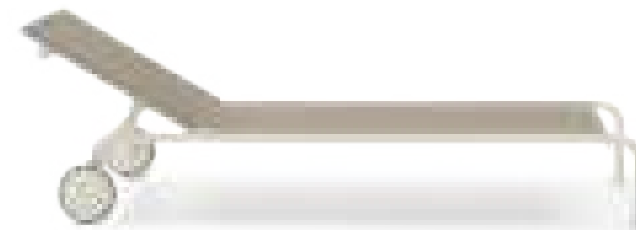

Three new sunbeds are completing Borea Collection. Unusualelliptic lines will outline the new dimensions of the relaxing area, while more traditional lines define the classic sunbed equipped with practical wheels. In the oval version the reclining back will divide asymmetrically the relaxing surface emphasizing their semicircular common shapes and a handy mattress defines the resting area.

Tre nuovi lettini completano la Collezione Borea. Insolite linee ellittiche delineano le nuove dimensioni della zona relax, mentre linee più tradizionali definiscono il classico lettino prendisole dotato di pratiche ruote. Nella versione ovale, lo schienale reclinabile divide in modo asimmetrico il piano relax enfatizzandone le forme semicirculari inconsuete e un comodo materasso ne definisce la zona di riposo.

The traditional practicality of rectangular sunbed with reclining back is enriched by an additional optical mattress and headrest for a more comfortable use. Ease of handling is ensured by the large wheels at the rear. Structure and mesh of the rectangular sunbed can be freely selected between neutral colours as dove grey or white. Besides the two neutral tones, elliptic sunbeds structures are also available in clay painted option to grant combinations with other elements and collections.

La tradizionale praticità del lettino rettangolare con schienale reclinabile è arricchita da un ulteriore materassino optional e poggiatesta per un utilizzo più confortevole. La maneggevolezza è assicurata dalle grandi ruote posteriori. La struttura e la rete del lettino rettangolare possono essere scelte liberamente tra colori neutri come tortora o bianco. Oltre alle due tonalità neutre, le strutture dei lettini ellittici sono disponibili anche in versione verniciata argilla per garantire abbinamenti con altri elementi e collezioni.

Borea

Piero Lissoni • 2021-2022

Inspiration • 22



Stackable products
Prodotti impilabili

The starting point of the seating collection are lightweight tubular aluminium structures that combine a fluid, continuous design with functionality and sustainability. The starting point of the seating collection are lightweight tubular aluminium structures that combine a fluid, continuous design with functionality and sustainability.

Aluminium's lightness combined with a well thought-out design allows the structures to be easily stacked so that they can be stored during winter in the smallest space. It is possible to stack up to three armchairs, three two-seater sofas, three three-seater sofas and six dining chairs.

Punto di partenza della collezione di sedute sono strutture leggere in tubolare d'alluminio che combinano un disegno fluido e continuo a contenuti di funzionalità e sostenibilità. L'alluminio rappresenta infatti una scelta sostenibile sia perché estremamente resistente e durevole sia perché interamente e facilmente riciclabile, quindi riutilizzabile all'infinito per dare vita

ogni volta a nuovi prodotti. La leggerezza dell'alluminio unita al design studiato nei minimi dettagli consente inoltre di impilare le strutture agevolmente così da poterle riporre durante la stagione invernale occupando il minor spazio possibile. È possibile impilare fino a 3 poltrone, 3 divani a due posti, 3 divani a tre posti, 6 poltroncine pranzo.

Borea
Piero Lissoni • 2021-2022
Inspiration • 22

Sofas
Divani

BE175

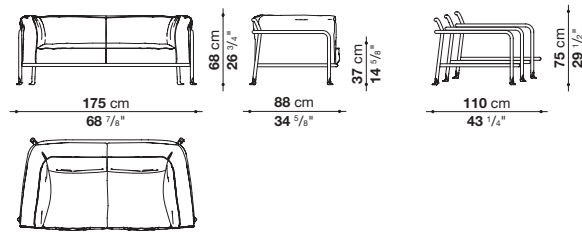

BE243

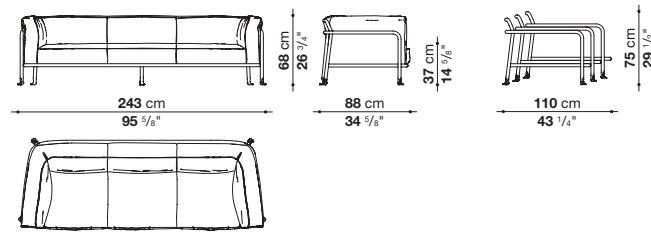

Oval sunbeds
Lettini ovali

BE150L

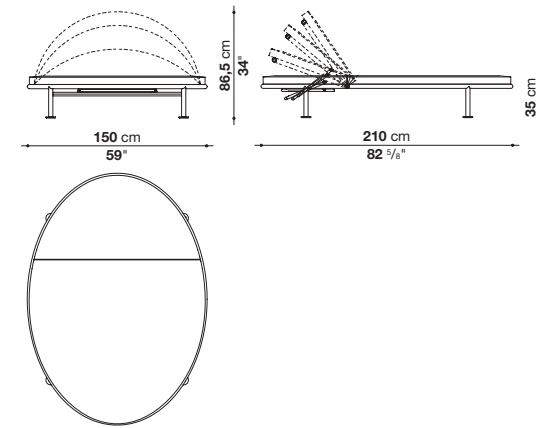

BE210L

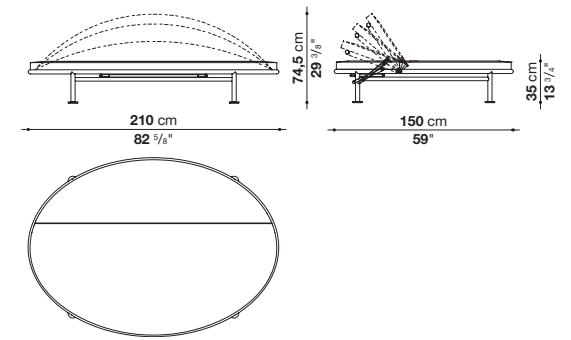

Armchair
Poltrona

BE1018

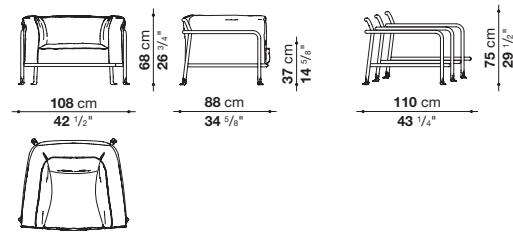

Rectangular sunbed
Lettino rettangolare

BE92L

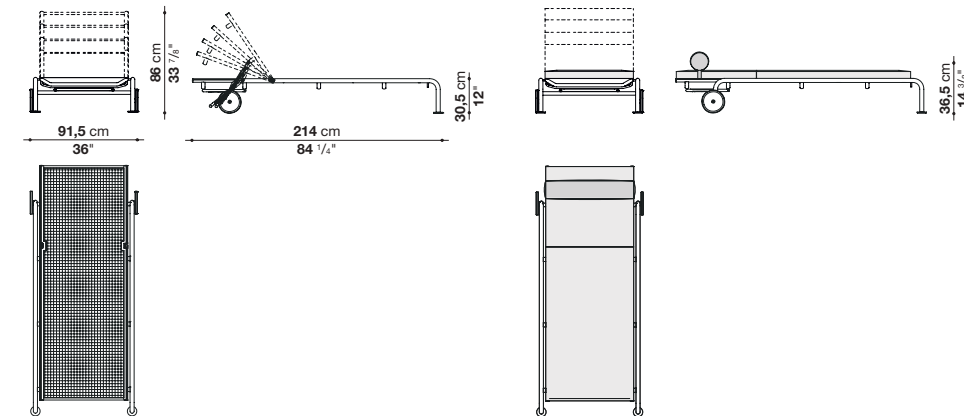

Small armchair
Poltroncina

BE69PB

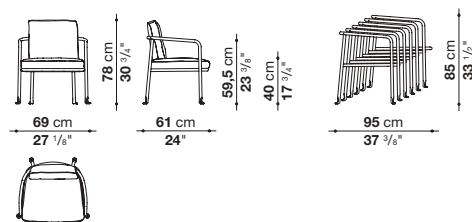

Chair
Sedia

BE69PA

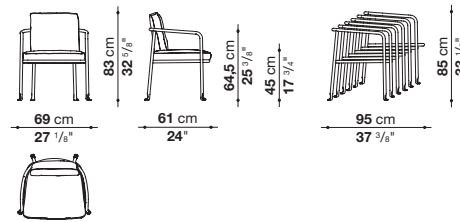

Borea

Piero Lissoni • 2021-2022

Frame	tubular and aluminium sheet
Upholstery	shaped polyurethane of different density, polyester fibre
Ferrules	thermoplastic material
Waterproof cover cloth	PES fabric coated on one side in PU
Cover	fabric in limited categories (with profile)

Struttura	tubolare e lamiera d'alluminio
Imbottitura	poliuretano sagomato a densità differenziata, fibra di poliestere
Puntali	materiale plastico
Telo di copertura impermeabile	tessuto PES monospalmato su un lato PU
Rivestimento	tessuto in categorie limitate (con profilo)

Profile

Profilo

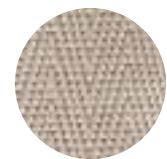

0041E
cream white
bianco panna



0082N
natural
naturale

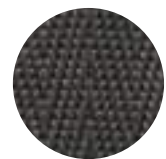

0054G
dark grey
grigio scuro

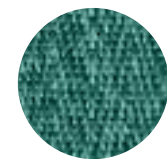

00585A
acquamarine
acquamarina

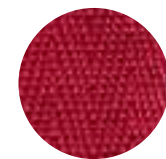

0075R
red
rosso

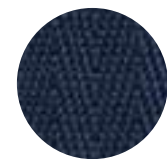

0095B
blue
blu

Frame

Struttura

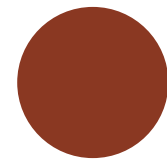

0750A
clay painted
verniciato argilla



0427S
sage painted
verniciato salvia

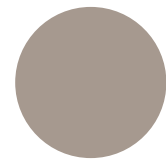

0380T
tortora painted
verniciato tortora

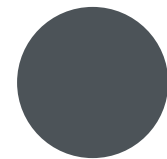

0236B
anthracite painted
verniciato antracite

Product items/Prodotti

Recommended combinations/Abbinamenti suggeriti



2563810
Agate



0085A
acquamarine profile
profilo acqua marina



0236B
anthracite painted
verniciato antracite



2620102
Aliseo



0095B
blu profile
profilo blu



0380T
tortora painted
verniciato tortora



2620102
Aliseo



2818210
Solano



2818215
Solano



0041E
cream white profile
profilo bianco panna



0236B
anthracite painted
verniciato antracite



2818210
Solano



0054G
dark grey profile
profilo grigio scuro



0750A
clay painted
verniciato argilla



2818815
Solano



0095B
blue profile
profilo blu



0236B
anthracite painted
verniciato antracite



2620102
Aliseo



0075R
profilo rosso
red profile



0750A
clay painted
verniciato argilla



2818815
Solano



0095B
blue profile
profilo blu



0236B
anthracite painted
verniciato antracite

Borea

Piero Lissoni • 2021-2022

Inspiration • 22

Frame	tubular and aluminium sheet
Upholstery	shaped polyurethane of different density, polyester fibre
Seat and back (BE92L)	mesh in Batyline® Canatex
Handle (BE92L)	aluminium
Wheels and ferrules	plastic material
Waterproof cover cloth	PES fabric coated on one side in PU
Cover	fabric in limited categories

Struttura	tubolare e lamiera d'alluminio
Imbottitura	poliuretano sagomato a densità differenziata, fibra di poliestere
Sedile e schienale (BE92L)	rete in Batyline® Canatex
Maniglia (BE92L)	alluminio
Ruote e puntali	materiale plastico
Telo copertura	tessuto PES monospalmato su un lato in PU
Rivestimento	tessuto in categorie limitate

Frame (BE150L - BE210L)

Struttura

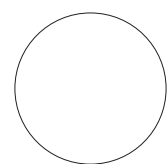

0186V
white painted
verniciato bianco

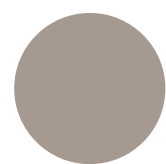

0380T
dove grey painted
verniciato tortora

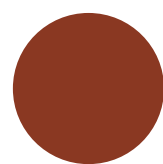

0750A
clay painted
verniciato argilla

Mesh (BE92L)

Rete

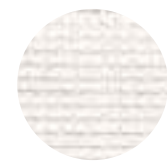

2445102
natural white Stige
Stige bianco naturale

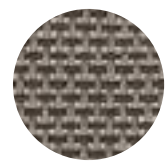

2445280
dove grey Stige
Stige tortora

Frame (BE92L)

Struttura

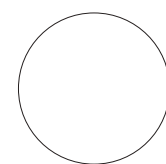

0186V
white painted
verniciato bianco

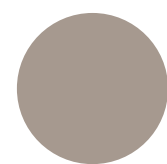

0380T
dove grey painted
verniciato tortora

Product items/Prodotti

Recommended combinations/Abbinamenti suggeriti

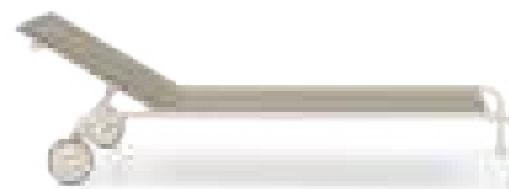

2445280
dove grey Stige
Stige tortora



0186B
white painted
verniciato bianco



2445280
dove grey Stige
Stige tortora



0380T
dove grey painted
verniciato tortora

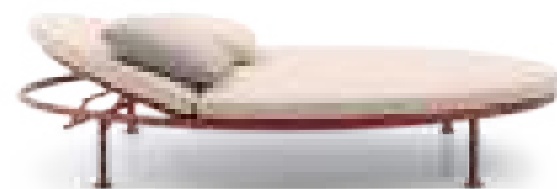

2821895
Lamone



2820811
Lila



2820100
Lila



0750A
clay painted
verniciato argilla



2821895
Lamone



2820811
Lila



2820100
Lila



0380T
dove grey painted
verniciato tortora

Borea

Piero Lissoni • 2021-2022

Inspiration • 22



The dining tables reflect the design and shades of the seating structures, but use steel instead of aluminum to support distinctive tops in teak and glazed lava stone. The lava stone comes from the slopes of Mount Etna (Sicily, Italy) and is available in large rectangular tiles in three bright colors - sage, clay and ocean blue - which harmonize perfectly with the whole collection. The glazed surface is made with a special material obtained by recycling the glass of discarded TV and PC monitors, applied directly to the stone through an exclusive manufacturing process. The tables are available in two sizes to accommodate six and eight people respectively: 244x105 cm and 285x105 cm.

I tavoli da pranzo riprendono il disegno e le tonalità delle strutture delle sedute, ma utilizzano l'acciaio al posto dell'alluminio per sostenere piani importanti in teak e in pietra lavica proveniente dalle pendici dell'Etna. Quest'ultima è interpretata con grosse piastrelle rettangolari smaltate in tre colori brillanti - salvia, argilla e blu oceano - che si armonizzano perfettamente con tutta la collezione. La superficie smaltata è realizzata con un materiale speciale ottenuto dal recupero del vetro di monitor di tv e pc dismessi, applicato direttamente alla pietra tramite un esclusivo processo di lavorazione. Due le dimensioni per ospitare rispettivamente sei e otto persone: cm 244x105 e cm 285x105.



The low tables designed to complement the sofas and chairs have the same tops composed of glazed lava stone tiles. They are available in two sizes - 121x105 cm and 162x105 cm - with structures in steel rod painted in dove grey, sage, clay and anthracite. The collection is enriched and completed by a series of round tables that offer multiple support solutions. The Borea coffee tables, in three sizes and heights, have thin structures in dove-gray, sage, clay and anthracite painted steel rod and are available with tops in glazed lava stone in sage, clay and ocean blue colors.

Il motivo del piano con piastrelle in pietra lavica smaltata è ripreso da tavoli bassi pensati come complemento per le sedute. Sono proposti in due dimensioni - cm 121x105 e cm 162x105 - con strutture in tondino di acciaio verniciato tortora, salvia, argilla e antracite. Ad arricchire e completare la collezione una serie di tavolini tondi che offrono molteplici soluzioni di appoggio. I tavolini Borea, in tre misure e altezze, hanno strutture sottili in tondino di acciaio verniciato tortora, salvia, argilla e antracite e prevedono piani in pietra lavica smaltata salvia, argilla e blu oceano.

Borea
Piero Lissoni • 2021-2022
Inspiration • 22



Borea

Piero Lissoni • 2021-2022

Inspiration • 22

Frame	tubular stainless steel
Top	enamelled lava stone
Ferrules and spacers	plastic material
Waterproof cover cloth	PES fabric coated on one side in PU

Struttura	tubolare d'acciaio inox
Piano	pietra lavica smaltata
Puntali e distanziali	materiale plastico
Telo di copertura impermeabile	tessuto PES monospalmato su un lato PU

Top Piano

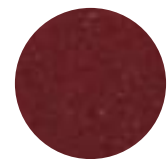

0032A
clay enamelled lava stone
pietra lavica smaltata argilla

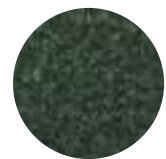

0057S
sage enamelled lava stone
pietra lavica smaltata salvia



0097B
ocean blue enamelled lava stone
pietra lavica smaltata blu oceano

Frame Struttura

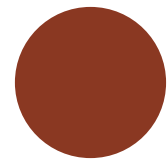

0750A
clay painted
verniciato argilla



0427S
sage painted
verniciato salvia

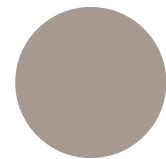

0380T
tortora painted
verniciato tortora

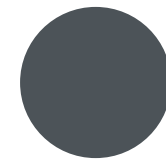

0236B
anthracite painted
verniciato antracite

The colours and materials shown are an indication. Images not in scale.
La tonalità dei colori e dei materiali è indicativa. Immagini non in scala.

Tables Tavoli

TBE244

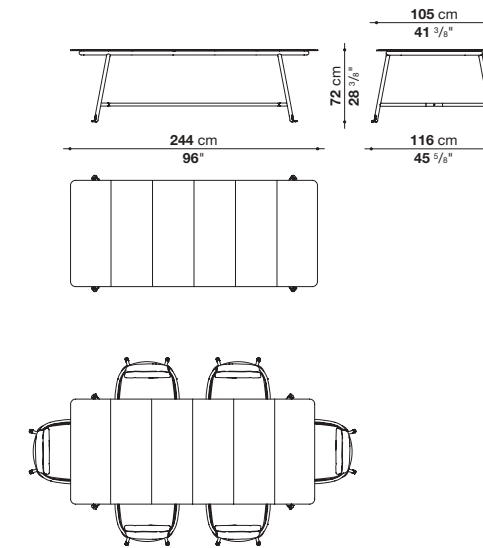

TBE285

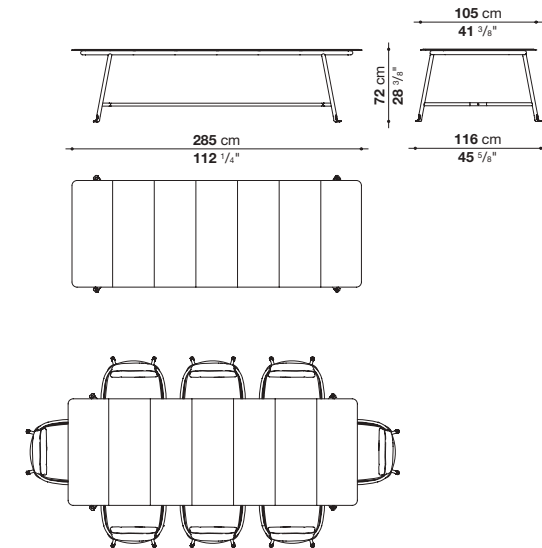

Low tables Tavoli bassi

TBE121

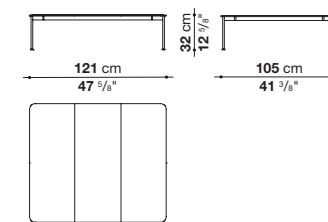

TBE162

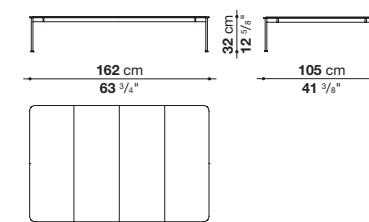

Round small tables Tavolini rotondi

TBE4

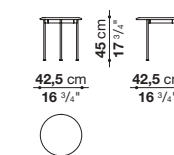

TBE6

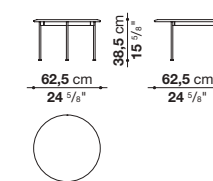

TBE8

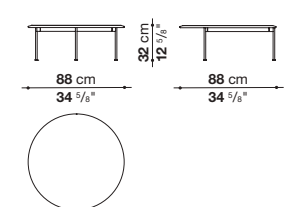

Butterfly

Patricia Urquiola • 2015

Inspiration • 184



Butterfly gets its name from the “butterfly” shape created by the outer corner that joins the armrest and the backrest. It is a modular seating system that responds effectively to the needs of modularity and comfort, suitable for free and informal usage. Its modular structure is shaped around an ottoman, which is the base piece, and which, when integrated with the backrest and/or the armrest, becomes a central or terminal element, either left or right. The combination of these elements, using a simple joint system, makes it possible to freely set up versatile configurations, from in-line sofas to corner solutions, from front facing to lounge layouts.

Butterfly prende il suo nome dalla forma a “farfalla” che disegna l’angolo esterno di unione tra bracciolo e schienale. È un sistema di sedute componibili che risponde in modo efficace ad esigenze di modularità e comfort, proponendo un utilizzo libero e informale. La struttura modulare si sviluppa intorno ad un pouf, il pezzo base, che integrato con schienale e/o bracciolo diventa poi un elemento centrale o terminale, destro o sinistro. Dall’accostamento tra questi elementi, tramite un semplice sistema di giunzione, nascono configurazioni libere e versatili, dai divani lineari a soluzioni angolari, da un accostamento vis-à-vis a soluzioni lounge.

The Butterfly complements have an outline that perfectly follows the lines of the sofa, harmoniously flanking the seat at the top. The family consists of two low tables and two small table featuring a large weave pattern, made of tortora coloured twisted polyethylene fibres that wraps around the grey painted aluminium frame. Two finishes are available for the surfaces of the complements: white Carrara marble “venatino statuarietto” or thermo-treated ash wooden slats.

I complementi Butterfly presentano una silhouette che riprende perfettamente l’andamento della struttura del divano, affiancandosi poi armoniosamente alla seduta nella parte alta. La famiglia si compone di due tavoli bassi e due tavolini caratterizzati da un intreccio grafico a dimensioni macro, realizzato con fibre di polietilene ritorte di color tortora, che avvolge la struttura in alluminio con finitura verniciato grigio. I piani dei complementi sono proposti in due finiture: marmo bianco di Carrara “venatino statuarietto” o in legno a doghe di frassino termotrattato.

Butterfly

Patricia Urquiola • 2015

Inspiration • 184

Terminal elements

Elementi terminali

BT112S

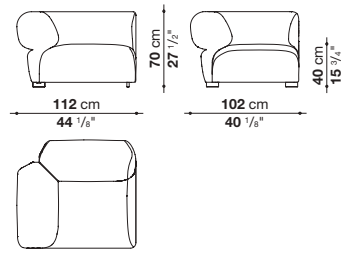

BT112D

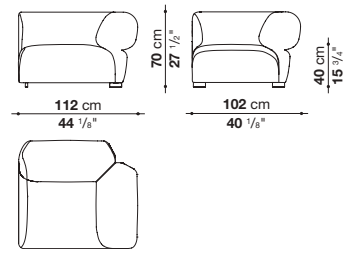

Central element

Elemento centrale

BT90C

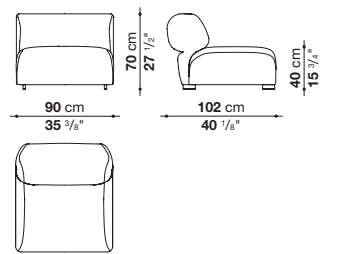

Ottoman

Pouf

BT90P

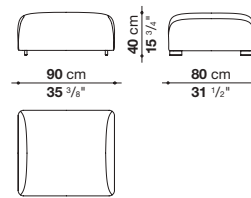

Small tables

Tavolini

BT7

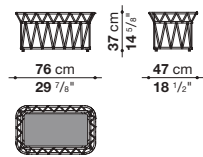

BT7Q

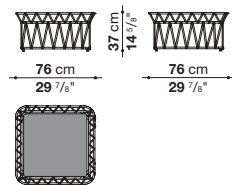

BT9R

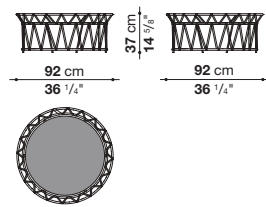

Low table

Tavolo basso

BT15

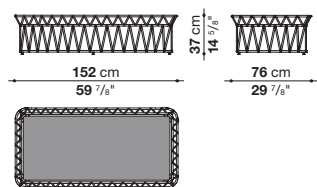

Internal frame	tubular steel and steel profiles	Telaio interno	tubolari e profilati d'acciaio
Internal frame upholstery	Bayfit® (Bayer®) flexible cold shaped polyurethane foam, water repellent polyester fibre cover (with heat-sealed ribbon)	Imbottitura telaio interno	schiuma di poliuretano flessibile a freddo Bayfit® (Bayer®), fodera in fibra di poliestere con trattamento idrorepellente (con cuciture termosaldate)
Frame (BT7-BT7Q-BT9R-BT15)	aluminium with polyester powder painting	Struttura (BT7-BT7Q-BT9R-BT15)	alluminio con verniciatura a polvere poliestere
Interlacing (BT7-BT7Q-BT9R-BT15)	polyethylene fibre	Intreccio (BT7-BT7Q-BT9R-BT15)	fibra di polietilene
Top (BT7-BT7Q-BT9R-BT15)	marble (natural finish) or wooden slats	Piano (BT7-BT7Q-BT9R-BT15)	marmo (finitura naturale) o doghe di legno
Feet, ferrules and fixing elements	thermoplastic material	Piedini, puntali ed elementi di fissaggio	materiale termoplastico
Waterproof cover cloth	PES fabric coated on one side in PU	Telo di copertura impermeabile	tessuto PES monospalmato su un lato PU
Cover	fabric in limited categories	Rivestimento	tessuto in categorie limitate

Interlacing

Intreccio

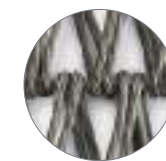

0612T
tortora polyethylene
polietilene tortora

Small tables top

Piano tavolini

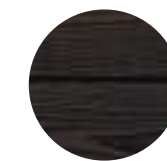

0430L
thermo-treated ash
frassino termotrattato

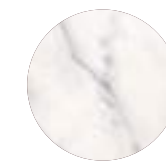

0900M
natural Carrara white
"venatino statuarietto" marble
marmo bianco Carrara
venatino statuarietto" naturale

The colours and materials shown are an indication. Images not in scale.
La tonalità dei colori e dei materiali è indicativa. Immagini non in scala.

Canasta

Patricia Urquiola • 2007

Inspiration • 204



The inspiration? A wicker basket in the Far East: Patricia Urquiola started working on the weave of Canasta (basket in Spanish) while out in the Far East. To find the perfect weave, the designer reinterpreted the traditional design of the octagonal holes in Viennese cane, mixed two patterns to transform the product into the macro-pattern of Canasta and create a series of outdoor sofas that look classic but have contemporary adaptability. In fact, the play between classic and contemporary is not a new idea: the Viennese cane inspiration is retro, and the polyethylene texture speaks today's language.

L'ispirazione? Una cesta in vimini vista in Estremo Oriente: Patricia Urquiola inizia da qui il lavoro sull'intreccio di Canasta (cesta, in spagnolo). Per trovare la trama perfetta la designer reinterpreta anche il tipico disegno a fori ottagonali della paglia di Vienna, mixa i due segni e li trasforma nel macro pattern geometrico di Canasta creando una serie di divani da giardino dalla memoria classica ma con plasticità contemporanea. Infatti il gioco tra il classico e il contemporaneo è senza alcuna nostalgia: se l'ispirazione alla paglia di Vienna è retro, la texture in polietilene parla il linguaggio di oggi.

A family of seating featuring a maxi-interlacing of white polyethylene fibre ribbon. There are many typologies: circular and linear sofas, armchairs and service elements. All these very comfortable seating have frames in aluminium with weather resistant polyester powder painting with interlacing in polyethylene fibre.

Famiglia di sedute caratterizzata dal macro-intreccio di nastri in fibra di polietilene bianca. Molteplici le tipologie: divani circolari e lineari, poltrone ed elementi di servizio. Tutte le sedute di grande comfort hanno la struttura in alluminio verniciato a polvere poliestere resistente agli agenti atmosferici e intreccio in fibra di polietilene.

Canasta

Patricia Urquiola • 2007

Inspiration • 204

Sofas
Divani

CN190B

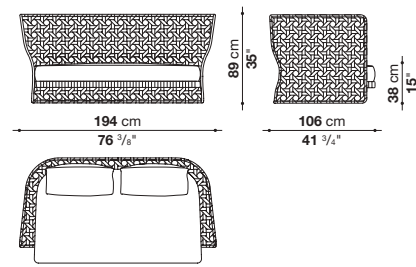

CN226B

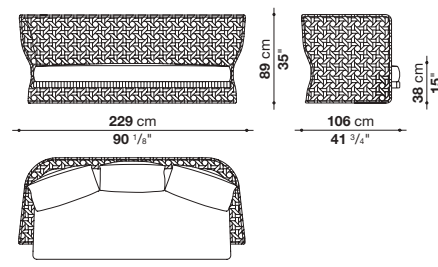

Armchairs
Poltrone

CN98PB

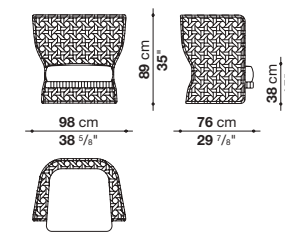

CN98PA

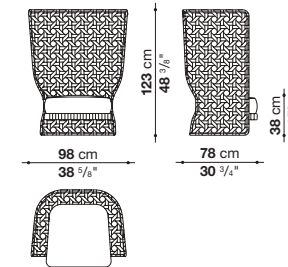

CN160P1

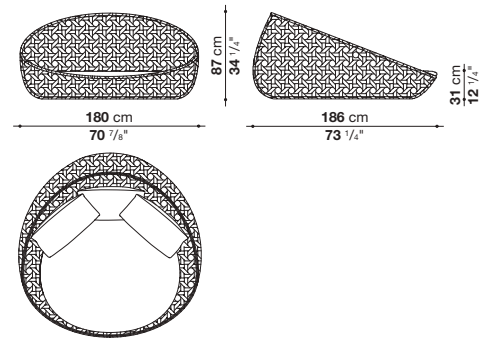

CN160P1, CN160P1W, CN160P1C

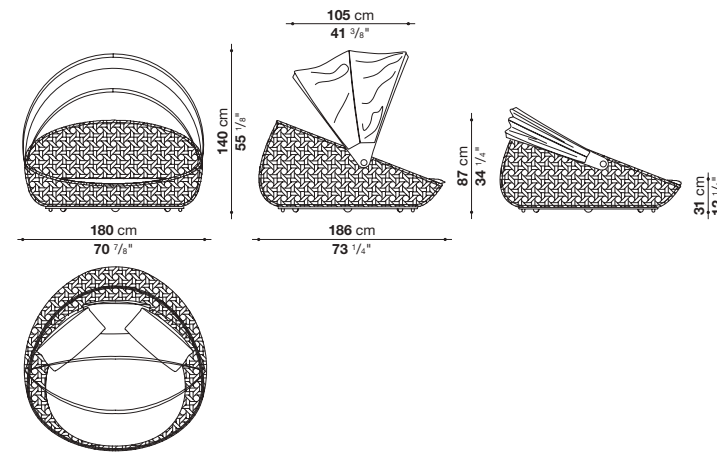

Service elements
Elementi di servizio

PCN60

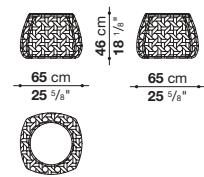

PCN80

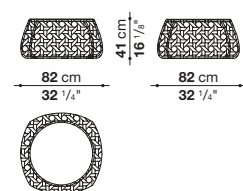

PCN110

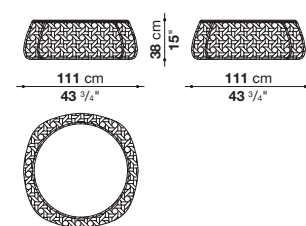

Canasta

Patricia Urquiola • 2007

Inspiration • 204

Frame	aluminium or steel with polyester powder painting
Interlacing	polyethylene fibre
Seat cushion (CN190B-CN226B-CN98PB-CN98PA)	shaped polyurethane, cover in water repellent polyester fibre (with heat-sealed ribbon)
Seat cushion (CN160P1)	shaped polyurethane, cover in water repellent polyester fibre
Back cushion	polyester fibre, cover in water repellent polyester fibre
Canopy frame (CN160P1C)	glass fibre
Canopy mechanism (CN160P1C)	electro polished steel, anodized aluminium
Canopy cover (CN160P1C)	Batik fabric
Wheels (CN160P1W)	plastic material, elastomeric polyurethane, electro polished stainless steel pin
Service element tray (PCN60-PCN80-PCN110)	steel sheet with polyester powder painting
Ferrules	thermoplastic material
Waterproof cover cloth	PES fabric coated on one side in PU
Cover	fabric in limited categories

Struttura	alluminio o acciaio con verniciatura a polvere poliestere
Intreccio	fibra di polietilene
Cuscino sedile (CN190B-CN226B-CN98PB-CN98PA)	poliuretano sagomato, fodera in fibra di poliestere con trattamento idrorepellente (con cuciture termosaldate)
Cuscino sedile (CN160P1)	poliuretano sagomato, fodera in fibra di poliestere con trattamento idrorepellente
Cuscino schienale	fibra di poliestere, fodera in fibra di poliestere con trattamento idrorepellente
Struttura capote (CN160P1C)	vetroresina
Meccanismo capote (CN160P1C)	acciaio elettrolucidato, alluminio anodizzato
Rivestimento capote (CN160P1C)	tessuto Batik
Ruote (CN160P1W)	materiale plastico, poliuretano elastomerico, perno in acciaio inox elettrolucidato
Vassoio elemento di servizio (PCN60-PCN80-PCN110)	lamiera d'acciaio con verniciatura a polvere poliestere
Puntali	materiale termoplastico
Telo di copertura impermeabile	tessuto PES monospalmato su un lato PU
Rivestimento	tessuto in categorie limitate

Product items/Prodotti

Recommended combinations/Abbinamenti suggeriti



2481255
Lesia



2481207
Lesia



0200W
white polyethylene
polietilene bianco



2369100
Bali



2376100
Bali fiorato



2563287
Agate



2593100
Batik
Batik



0200W
white polyethylene
polietilene bianco



2481255
Lesia



2481101
Lesia



0200W
white polyethylene
polietilene bianco



2481255
Lesia



2481207
Lesia



0200W
white polyethylene
polietilene bianco

Interlacing Intreccio

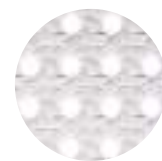

0200W
white polyethylene
polietilene bianco

Canopy cover (CNC160P1) Rivestimento capote



2593100
white Batik fabric
tessuto Batik bianco

Tray (PCN60 - PCN80 - PCN110) Vassoio

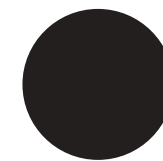

09005
black painted
verniciato nero

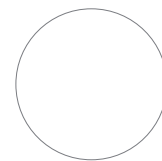

0179A
white painted
verniciato bianco



0179A
white painted
verniciato bianco



0200W
white polyethylene
polietilene bianco

Canasta tables

Patricia Urquiola • 2007/2013

Inspiration • 208

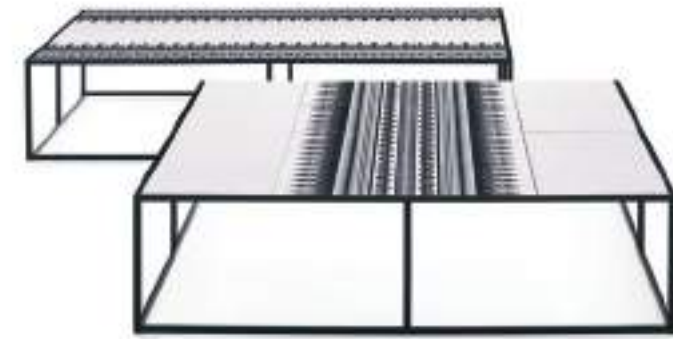

The Canasta collection includes tables and low tables in different sizes. The tables frames are in aluminium and the low tables frames are in steel. Both frames are painted with weather resistant polyester powder. The tops are covered with exclusive tiles with decorative patterns.

La collezione Canasta si completa di tavoli e tavoli bassi in diverse dimensioni. I tavoli hanno la struttura in alluminio mentre i tavoli bassi in acciaio. Entrambe le strutture sono verniciate a polvere poliestere resistente agli agenti atmosferici e piani rivestiti con piastrelle esclusive con motivi decorativi.

Canasta tables

Patricia Urquiola • 2007/2013

Inspiration • 208

Canasta tables

Canasta tavoli

TCN224

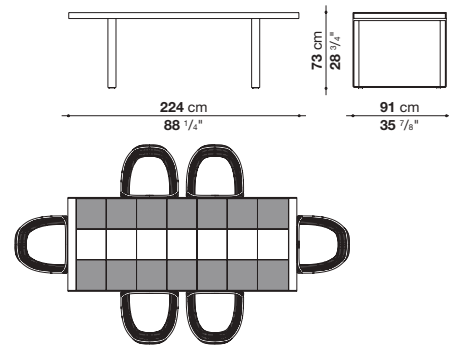

TCN283N

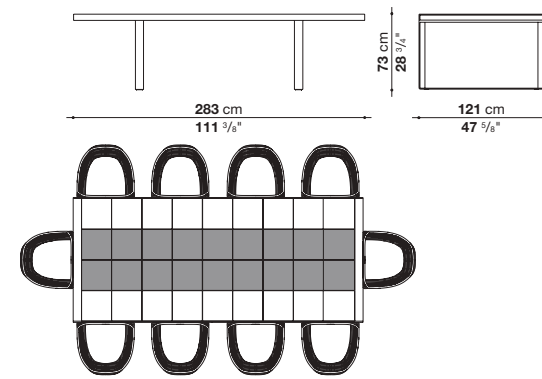

Low tables

Tavoli bassi

TCN12

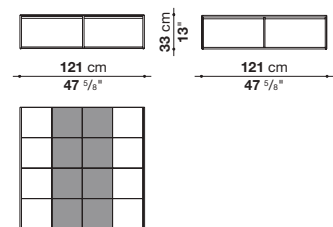

TCN15

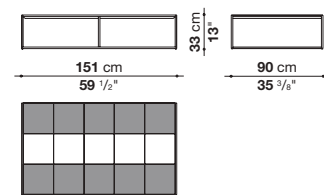

Frame	aluminium or steel with polyester powder painting	Struttura	alluminio o acciaio con verniciatura a polvere poliesteri
Top	tiles in porcelain stoneware	Piano	piastrelle in gres porcellanato
Ferrules	thermoplastic material	Puntali	materiale termoplastico
Waterproof cover cloth	PES fabric coated on one side in PU	Telo di copertura impermeabile	tessuto PES monospalmato su un lato PU

Top

Piano

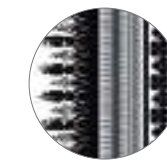

1510A
porcelain stoneware with
black / white decoration
gres porcellanato con
decoro nero / bianco

Frame (TCN224 - TCN283N)

Struttura

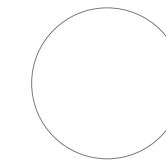

0179A
white painted
verniciato bianco

Frame (TCN12 - TCN15)

Struttura

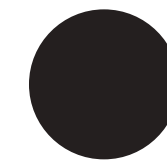

09005
black painted
verniciato nero

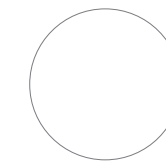

0179A
white painted
verniciato bianco

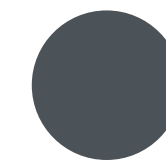

0236B
anthracite painted
verniciato antracite

The colours and materials shown are an indication. Images not in scale.
La tonalità dei colori e dei materiali è indicativa. Immagini non in scala.

Canasta '13
 Patricia Urquiola • 2013
 Inspiration • 198



Outdoor sofas, swivel sofas, high and low back armchairs for the garden from the Canasta '13 collection maintain the iconic design and the typologies of the entire Canasta series, but with a new look designed to blend in with the external environment even more. The colours of the woven material become more natural,

I divani da esterno, divani girevoli, poltrone alte e basse da esterno della collezione Canasta '13 mantengono il design iconico e le tipologie di tutta la serie Canasta e cambiano "veste" per fondersi maggiormente con l'ambiente esterno. I colori dell'intreccio si fanno più naturali tingendosi di un tortora mélange e la trama dell'intreccio

Tortora mélange, and the weave expands to let light and glimpses of the surroundings show through. Unique pieces, elegant outdoor furnishings that are super comfortable like the circular sofa with the swivel base, which lets you follow the sun and turn 360°.

si dispiega lasciando trasparire la luce e l'ambiente circostante. Pezzi unici, protagonisti eleganti dell'arredamento da esterno e super confortevoli come il divano circolare oversize con la base girevole per seguire il sole a 360°.

Canasta '13

Patricia Urquiola • 2013

Inspiration • 198

Sofas
Divani

CNC190B

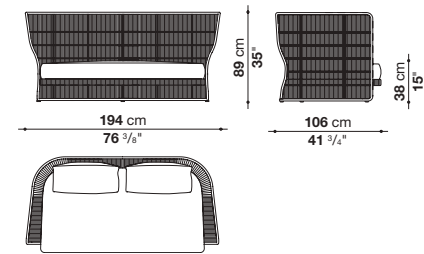

CNC226B

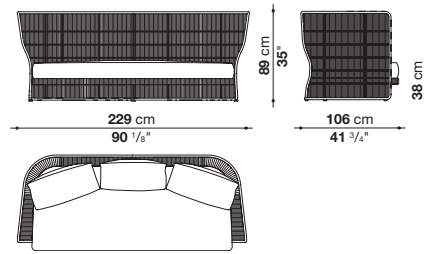

Armchairs
Poltrone

CNC98PB

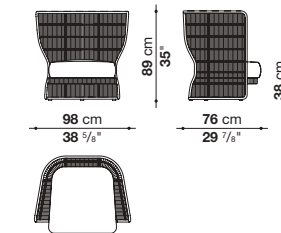

CNC98PA

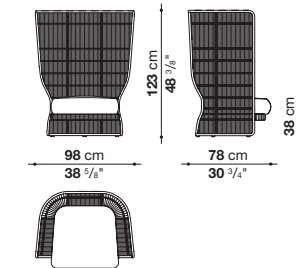

CNC160P1

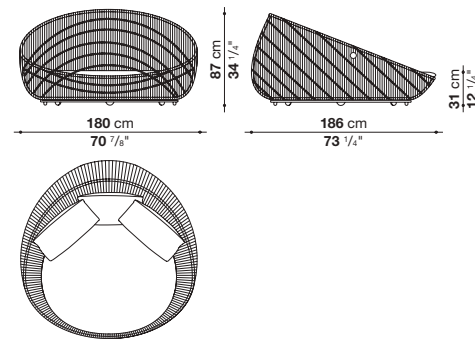

CNC160P1, CNC160P1C

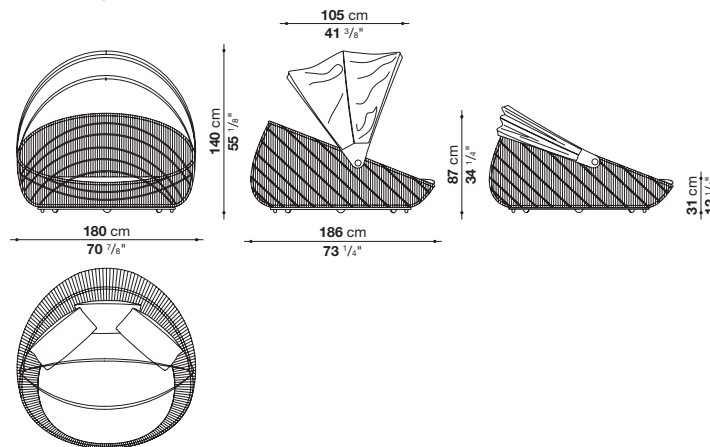

Chair
Sedia

SCNC63

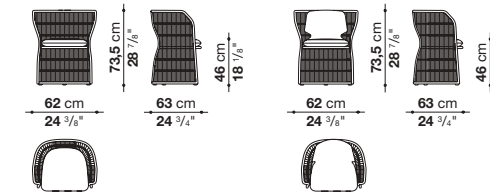

Service elements
Elementi di servizio

PCNC60

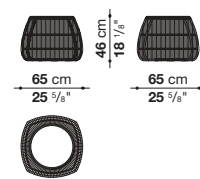

PCNC80

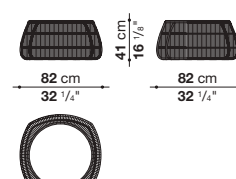

PCNC110

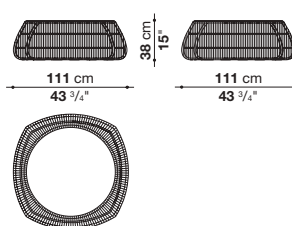

Small tables
Tavolini

TCNC3

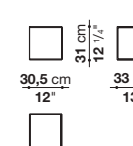

TCNC4

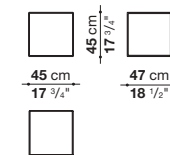

Canasta '13

Patricia Urquiola • 2013

Inspiration • 198

Frame	aluminium or steel with polyester powder painting
Interlacing	polyethylene fibre
Seat cushion (CNC190B-CNC226B-CNC98PB-CNC98PA)	shaped polyurethane, cover in water repellent polyester fibre (with heat-sealed ribbon)
Seat cushion (CNC160P1-SCNC63)	shaped polyurethane, cover in water repellent polyester fibre
Back cushion	polyester fibre, cover in water repellent polyester fibre
Canopy frame (CNC160P1C)	glass fibre
Canopy mechanism (CNC160P1C)	electro polished steel, anodized aluminium
Canopy cover (CNC160P1C)	Balivo fabric
Service element tray (PCNC60-PCNC80-PCNC110)	steel sheet with polyester powder painting
Wheels and ferrules	thermoplastic material
Cover	fabric in limited categories
Fame (TCNC3-TCNC4)	aluminium or steel with polyester powder painting
Top (TCNC3-TCNC4)	tiles in cement porcelain stoneware
Ferrules (TCNC3-TCNC4)	thermoplastic material
Waterproof cover cloth	PES fabric coated on one side in PU

Struttura	alluminio o acciaio con verniciatura a polvere poliestere
Intreccio	fibra di polietilene
Cuscino sedile (CNC190B-CNC226B-CNC98PB-CNC98PA)	poliuretano sagomato, fodera in fibra di di poliestere con trattamento idrorepellente (con cuciture termosaldate)
Cuscino sedile (CNC160P1-SCNC63)	poliuretano sagomato, fodera in fibra di poliestere con trattamento idrorepellente
Cuscino schienale	fibra di poliestere, fodera in fibra di poliestere con trattamento idrorepellente
Struttura capote (CNC160P1C)	vetroresina
Meccanismo capote (CNC160P1C)	acciaio elettrolucidato, alluminio anodizzato
Rivestimento capote (CNC160P1C)	tessuto Balivo
Vassoio elemento di servizio (PCNC60-PCNC80-PCNC110)	lamiera d'acciaio con verniciatura a polvere poliestere
Ruote e puntali	materiale termoplastico
Rivestimento	tessuto in categorie limitate
Struttura (TCNC3-TCNC4)	alluminio o acciaio con verniciatura a polvere poliestere
Piano (TCNC3-TCNC4)	piastrelle in gres porcellanato cemento
Puntali (TCNC3-TCNC4)	materiale termoplastico
Telo di copertura impermeabile	tessuto PES monospalmato su un lato PU

Interlacing Intreccio

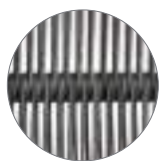

0280P
tortora polyethylene
polietilene tortora

Canopy cover (CNC160P1) Rivestimento capote

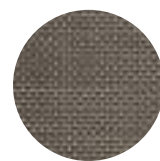

2387280
tortora Balivo fabric
tessuto Balivo tortora

Tray (PCNC60 - PCNC80 - PCNC110) Vassoio

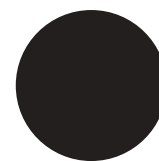

09005
black painted
verniciato nero

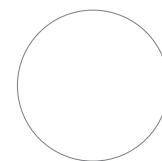

0179A
white painted
verniciato bianco

Top (TCNC3 - TCNC4) Piano



1560E
cement porcelain stoneware
gres porcellanato cemento

Frame (TCNC3 - TCNC4) Struttura

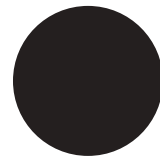

09005
black painted
verniciato nero

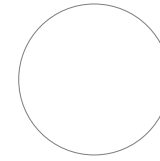

0179A
white painted
verniciato bianco

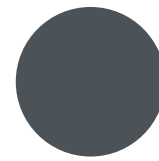

0236B
anthracite painted
verniciato antracite

The colours and materials shown are an indication. Images not in scale.
La tonalità dei colori e dei materiali è indicativa. Immagini non in scala.

Product items/Prodotti Recommended combinations/Abbinamenti suggeriti



2481255
Lesia



2485255
Lipari



0280P
tortora
polyethylene
polietilene
tortora



2481255
Lesia



2481207
Lesia



2485255
Lipari



2387280
Balivo
Balivo



*** 0280P**
tortora
polyethylene
polietilene
tortora



2481877
Lesia



2481251
Lesia



0280P
tortora
polyethylene
polietilene
tortora



0179A
white
painted
verniciato
bianco



2481877
Lesia



2481251
Lesia



0280P
tortora
polyethylene
polietilene
tortora



0280P
tortora
polyethylene
polietilene
tortora



0179A
white
painted
verniciato
bianco

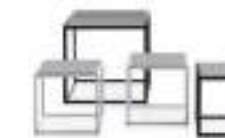

0179A
white painted
verniciato
bianco



09005
black painted
verniciato nero



1560E
cement porcelain
stoneware
gres porcellanato
cemento

The colours and materials shown are an indication. Images not in scale.
La tonalità dei colori e dei materiali è indicativa. Immagini non in scala.

Charles Outdoor

Antonio Citterio • 2010
Inspiration • 158



The Charles sofa system, a long-time bestseller for the company, is being introduced in an outdoor version: Charles Outdoor. Characteristics that made it a classic of pure contemporary taste have been left unchanged. The system will have the same slim frame, flexibility and signature design of the inverted “L” shape aluminium foot.

Il sistema di divani Charles, bestseller e longseller dell'azienda, viene proposto nella versione outdoor: Charles Outdoor. Rimangono inalterate le caratteristiche che lo hanno reso un classico dal gusto decisamente contemporaneo: la struttura sottile, la flessibilità del sistema e il design essenziale del piedino in alluminio a forma di “L” rovesciata.

Charles Outdoor
Antonio Citterio • 2010
Inspiration • 158



2571207
Sirocco

2530280
Lesia

2498102
Leila

2481101
Lesia

2485280
Lipari



Charles Outdoor

Antonio Citterio • 2010

Inspiration • 158

Sofa
Divano

CHO234

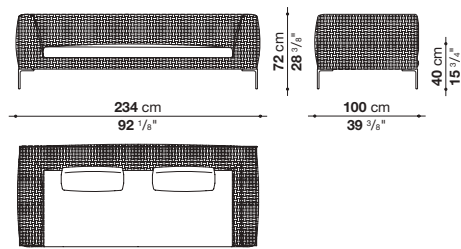

Terminal elements
Elementi terminali

* CHO160D

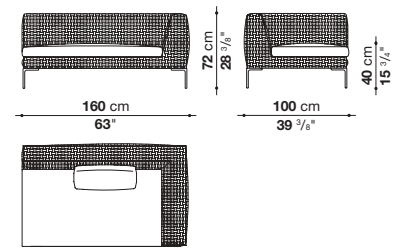

* CHO234D

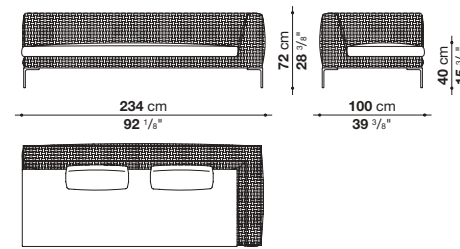

Chaise longue
Chaise longue

* CHO160LD

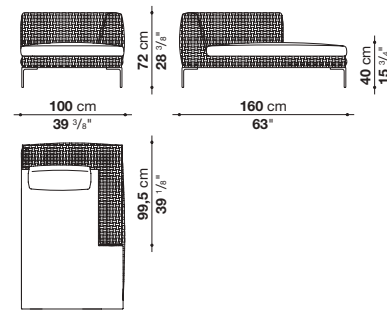

* CHO234LD

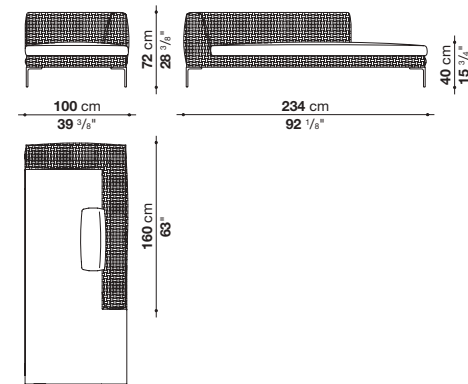

Armchair
Poltrona

CHO84

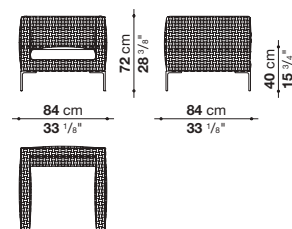

* Elements available in right and left version. / Elementi disponibili nella versione destra e sinistra.
The colours and materials shown are an indication. Images not in scale.
La tonalità dei colori e dei materiali è indicativa. Immagini non in scala.

Internal frame	tubular aluminium and aluminium profiles
Interlacing	polypropylene fibre
Seat cushion	shaped polyurethane, cover in water repellent polyester fibre
Back cushion	polyester fibre, cover in water repellent polyester fibre
Feet	die-cast aluminium with polyester powder painting
Ferrules	thermoplastic material
Waterproof cover cloth	PES fabric coated on one side in PU
Cover	fabric in limited categories

Telaio interno	tubolari e profilati d'alluminio
Intreccio	fibra di polipropilene
Cuscino sedile	poliuretano sagomato, fodera in fibra di poliesteri con trattamento idrorepellente
Cuscino schienale	fibra di poliestere, fodera in fibra di poliestere con trattamento idrorepellente
Piedini	fusione d'alluminio con verniciatura a polvere poliestere
Puntali	materiale termoplastico
Telo di copertura impermeabile	tessuto PES monospalmato su un lato PU
Rivestimento	tessuto in categorie limitate

Interlacing
Intreccio

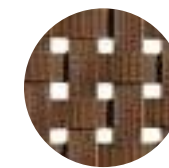

0115P
brown polypropylene
polipropilene marrone

Feet
Piedini

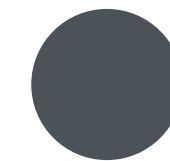

0174B
bronzed nickel painted
verniciato nickel bronzato

The colours and materials shown are an indication. Images not in scale.
La tonalità dei colori e dei materiali è indicativa. Immagini non in scala.

Colosseo Outdoor

Naoto Fukasawa • 2020

Inspiration • 244



In 2020 Colosseo debuts outdoor in the new porcelain stoneware version in sage and clay colors. A furnishing element with various functions depending on the occasion and need (coffee table and pouf). Colosseo takes its name from the designer's inspiration. Naoto Fukasawa has in fact arrived at the desired shape thinking of a solid in the shape of an upside-down truncated cone, creating an assonance with the structure of the famous Roman arena.

Nel 2020 Colosseo debutta nella nuova versione Outdoor, in gres porcellanato nei colori salvia e argilla. Elemento di arredo con varie funzioni a seconda delle occasioni e delle necessità (pouf e tavolino), Colosseo prende il nome dall'ispirazione del designer. Naoto Fukasawa è arrivato alla forma desiderata pensando ad un solido a forma di tronco di cono rovesciato alleggerito nella struttura da incavi a forma di arco, creando così una assonanza con la famosa arena romana.

Frame and top	stoneware	Struttura e piano	gres
Ferrules	plastic material	Puntali	materiale plastico

Service elements

Elementi di servizio

OCL40T

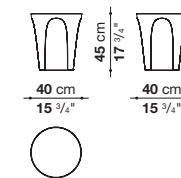

OCL45T

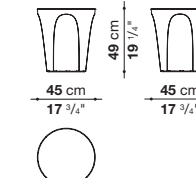

Top and frame

Piano e struttura

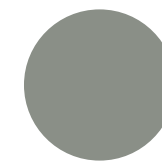

0416S
sage stoneware
gres salvia

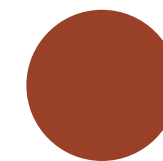

0302A
clay stoneware
gres argilla

The colours and materials shown are an indication. Images not in scale.
La tonalità dei colori e dei materiali è indicativa. Immagini non in scala.

Cosmos Outdoor

Jeffrey Bennett - 2019

Inspiration • 224



This collection includes harmonious tables which can be used in pairs or groups due to their compact size. They adapt easily to different environments both as contract furnishing schemes and residential balconies or terraces. These tables are entirely painted (sage, clay or anthracite) or with tops in porcelain stoneware (white or anthracite).

La collezione include una serie di tavoli dalle linee armoniose che possono essere utilizzati in coppia o in piccoli gruppi. La versatilità che li contraddistingue ne permette l'adattabilità a diversi contesti. Da progetti contract a balconi e terrazze ad uso residenziale. I tavoli possono essere interamente verniciati (salvia, argilla o antracite) oppure con il piano in gres porcellanato (bianco o antracite).

Frame	aluminium
Top	porcelain stoneware
Ferrules	thermoplastic material

Struttura	alluminio
Piano	gres porcellanato
Puntali	materiale plastico

Tables

Tavoli

OTC90R_2

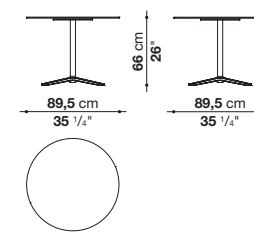

OTC90R_1

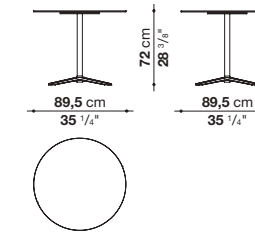

OTC90Q_2

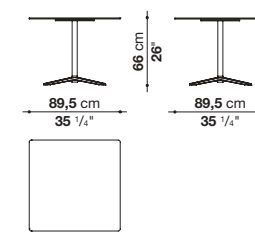

OTC90Q_1

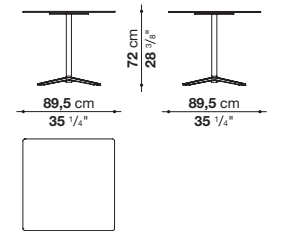

Frame

Struttura



0427S
sage painted
verniciato salvia

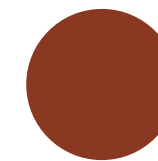

0750A
clay painted
verniciato argilla



0236B
anthracite painted
verniciato antracite

Top

Piano



* 0355N
anthracite stone
porcelain stoneware
gres porcellanato
pietra antracite

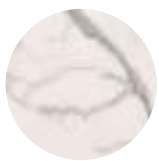

* 0266B
white statuary
porcelain stoneware
gres porcellanato
statuario bianco

* Image not in scale / Immagine non in scala

Crinoline

Patricia Urquiola • 2008

Inspiration • 212



Can you picture the dresses that women wore in the 1800s? Full, bell-shaped skirts held by crinolines (rigid underskirt garments) were spectacular “micro-architectures” commonly seen in living rooms everywhere. All of the chairs in the Crinoline collection are designed to reflect this elegant look: the wide curve of the base is repeated in the seat and the curve of the backrest.

Avete presente le gonne delle dame ottocentesche? Gonfie, a campana, sostenute dalle crinoline (sottogonne rigide) erano scenografiche micro-architetture da salotto. “Più che romantica. Più che sensuale. L'ispirazione è esotica ed erotica”, dice Patricia Urquiola. Le poltrone e sedie Crinoline sono disegnate per rendere l'idea di questi abiti eleganti: l'ampia conca della base è ripresa nella seduta e nella curvatura dello schienale.

Armchairs, small armchairs, chairs and a stool are designed in several different shapes and heights. The polyethylene fibre interlacing are joined by natural or bronze abaca. Being a natural material, the product with abaca interlacing is suitable for indoors, covered outdoor spaces or verandas.

Sedie, uno sgabello, poltroncine e poltrone sono declinate in tipologie diverse per forma e altezza. Ad intrecci in fibra di polietilene, si affiancano quelli in abaca naturale o bronzo. Il prodotto con intreccio in abaca naturale, trattandosi di fibra naturale, è destinato all'utilizzo in ambienti interni, in esterni coperti o verande.

Crinoline

Patricia Urquiola • 2008

Inspiration • 212

Armchairs

Poltrone

C5P

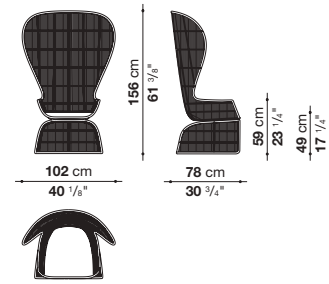

C5C

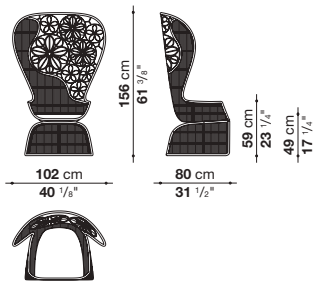

Small armchair

Poltroncina

C3P

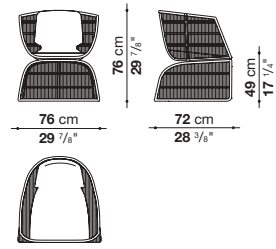

Chairs

Sedie

C1PF

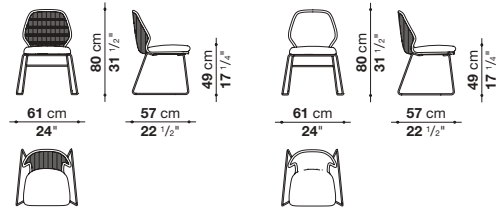

C2PF

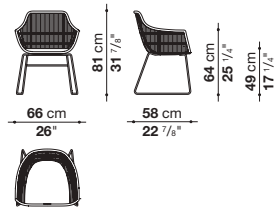

C2P

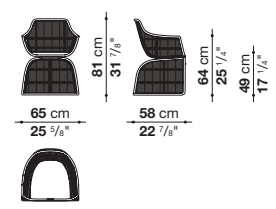

Stools

Sgabelli

C6PF

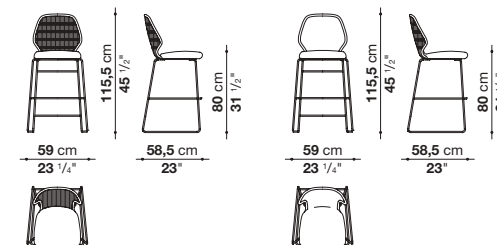

C7PF

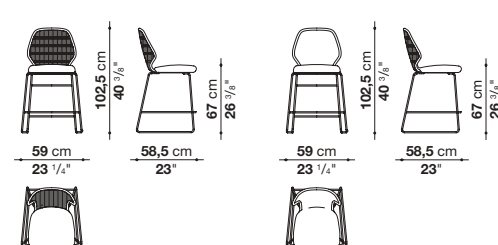

Base-frame	stainless steel or aluminium with polyester powder painting
Seat and back frame	aluminium with polyester powder painting
Seat cushion/Seat and back cushion	shaped polyurethane, cover in water repellent polyester fibre
Seat cushion (C5P-C5C)	shaped polyurethane, cover in water repellent polyester fibre (with heat-sealed ribbon)
Interlacing	polyethylene fibre or abaca
Ferrules	thermoplastic material
Waterproof cover cloth	PES fabric coated on one side in PU
Cover	fabric in limited categories

Struttura base	alluminio con verniciatura a polvere poliesteri o acciaio inossidabile
Struttura sedile e schienale	alluminio con verniciatura a polvere poliesteri
Cuscino sedile/Cuscino sedile e schienale	poliuretano sagomato, fodera in fibra di poliesteri con trattamento idrorepellente
Cuscino sedile (C5P-C5C)	poliuretano sagomato, fodera in fibra di poliesteri con trattamento idrorepellente (con cuciture termosaldate)
Intreccio	fibra di polietilene o abaca
Puntali	materiale termoplastico
Telo di copertura impermeabile	tessuto PES monospalmato su un lato PU
Rivestimento	tessuto in categorie limitate

Stools

Sgabelli

C6PF

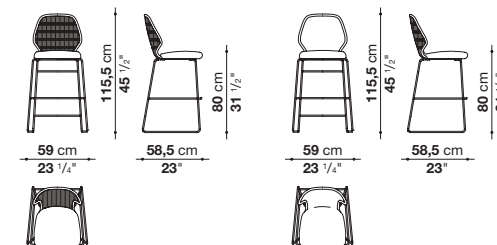

C7PF

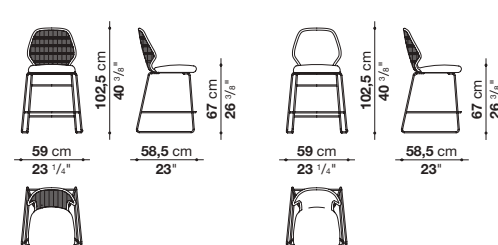

Interlacing

Intreccio

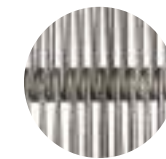

0280P
tortora polyethylene
polietilene tortora

Interlacing (C5C)

Intreccio

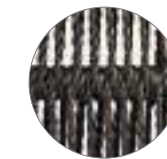

0360C
grey abaca
abaca grigio

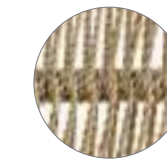

0203C
natural abaca
abaca naturale

The colours and materials shown are an indication. Images not in scale.
La tonalità dei colori e dei materiali è indicativa. Immagini non in scala.

Erica
 Antonio Citterio • 2017
 Inspiration • 116



Sofas, armchair, small armchair and chair, including a stackable version, offer a technological blend of extruded and die-cast aluminium elements.

Their lightness and design makes them ideal for both public and residential settings, featuring seat and back cushions for ergonomic comfort together with strength for outdoor use.

The painted frames are available in two finish combinations: tortora painted aluminium frame with tortora colour polypropylene fibre interlacing or anthracite painted aluminium frame with anthracite colour polypropylene fibre interlacing.

Divani, poltrona, poltroncina e sedia, anche in versione impilabile, sono studiati con un mix tecnologico di estrusi e pressofusioni di alluminio. La loro leggerezza e il loro disegno ne suggeriscono l'utilizzo sia in spazi pubblici che residenziali, rispettando criteri di ergonomia e adattabilità ambientale. I cuscini sedile e schienale garantiscono un confortevole relax. Due le finiture delle strutture verniciate, abbinata ad intrecci di nastri in tessuto sintetico con un'anima interna ad alta tenacità studiata per l'utilizzo outdoor: struttura in alluminio verniciato tortora con intreccio in fibra di polipropilene tortora o struttura in alluminio verniciato antracite con intreccio in fibra di polipropilene antracite.

Erica

Antonio Citterio • 2017

Inspiration • 116

Sofas

Divani

E170

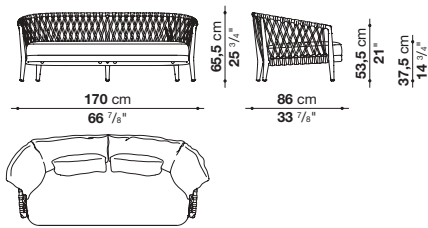

E216

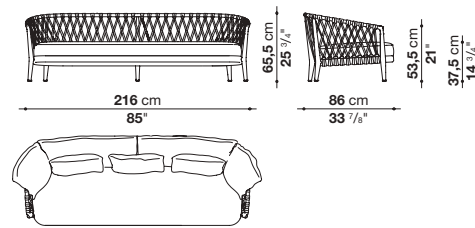

Small armchair

Poltroncina

E80P

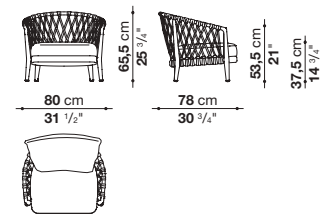

Armchair

Poltrona

E90P

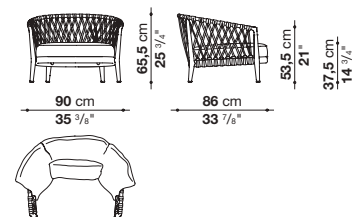

Chairs

Sedie

E61S

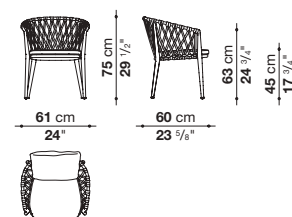

E61S_1

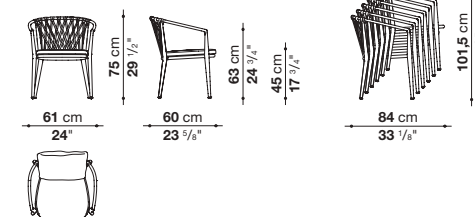

Erica

Antonio Citterio

Frame	die-cast aluminium and extrusions with polyester powder painting	Struttura	pressofusione ed estrusi d'alluminio con verniciatura a polvere poliestere
Back upholstery (E170-E216-E90P-E80P)	shaped polyurethane of different density, Solutex fibre and visco-elastic polyurethane combination, cover in water repellent polyester fibre	Imbottitura schienale (E170-E216-E90P-E80P)	poliuretano sagomato a densità differenziata, combinazione fibra Solutex e poliuretano viscoelastico, fodera in fibra di poliestere con trattamento idrorepellente
Back upholstery (E61S-E61S_1)	polyester fibre and polyurethane combination	Imbottitura schienale (E61S-E61S_1)	combinazione fibra di poliestere e poliuretano
Seat upholstery	shaped polyurethane, Solutex fibre and visco-elastic polyurethane combination, cover in water repellent polyester fibre (with heat-sealed ribbon)	Imbottitura sedile	poliuretano sagomato, combinazione fibra Solutex e poliuretano viscoelastico, fodera in fibra di poliestere con trattamento idrorepellente (con cuciture termosaldate)
Interlacing	polypropylene fibre braid	Intreccio	treccia in fibra di polipropilene
Seat webbing	polypropylene fibre and synthetic rubber threads	Cinghiatura sedile	fibra di polipropilene e fili di gomma sintetica
Ferrules	thermoplastic material	Puntali	materiale termoplastico
Waterproof cover cloth	PES fabric coated on one side in PU	Telo di copertura impermeabile	tessuto PES monospalmato su un lato PU
Cover	fabric in limited categories	Rivestimento	tessuto in categorie limitate

Frame and interlacing matching

Abbinamento struttura e intreccio



0828T

tortora painted / tortora polypropylene
verniciato tortora / polipropilene tortora



0625G

anthracite painted / anthracite polypropylene
verniciato antracite / polipropilene antracite

The colours and materials shown are an indication. Images not in scale.
La tonalità dei colori e dei materiali è indicativa. Immagini non in scala.

Erica '19
Antonio Citterio • 2019
Inspiration • 106



The Erica collection of sofas, armchairs and small chairs that was so successfully launched in 2017 has been enhanced by new sofas, still based on the same characteristic curved backrest and interlacing as before but offering a deeper seat and lived-in appearance. The sofas come in three extra-comfortable sizes - the 170 cm and 216 cm styles with a 96 cm deep seat and the 153 cm version with a 140 cm seat - and the cushions have a different type of filling giving an even softer and more natural look and making them even more inviting.

Erica, la collezione di divani, poltrone e poltroncine presentata con successo nel 2017, si arricchisce di nuovi divani che riprendono lo schienale curvo e l'intreccio caratteristici della serie, ma si distinguono per la seduta più profonda e l'aspetto vissuto. I divani sono proposti in tre misure particolarmente accoglienti 170 cm e 216 cm con seduta profonda 96 cm e 153 cm con seduta profonda 140 cm e prevedono, per i cuscini, una nuova tipologia di imbottitura che conferisce al prodotto un aspetto più morbido e naturale, un vero e proprio invito al relax.

The unusual colour juxtaposition of frame and interlacing in anthracite, tortora or a frame in sage with natural-coloured interlacing can be complemented by a vast range of cushion covers, in an array of tones and designs, all co-ordinating with each other. There is also a chair with armrests with an brand new interlaced backrest.

Inediti gli accostamenti cromatici con struttura e intreccio antracite, tortora oppure con struttura salvia e intreccio naturale, da abbinare ad un'ampia gamma di rivestimenti per i cuscini proposti in numerose nuance e fantasie tra loro coordinabili. La proposta è completata dalla sedia con braccioli con un inedito intreccio per lo schienale.

Erica '19
Antonio Citterio • 2019
Inspiration • 106

Sofas
Divani

9NE170

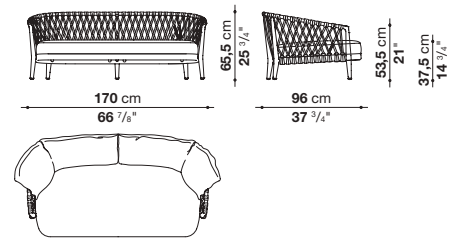

9NE216

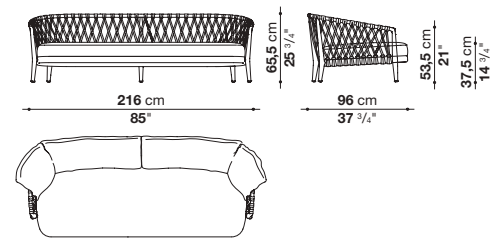

NE153

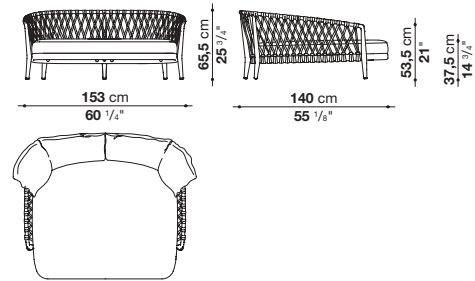

Small armchair
Poltroncina

NE80P

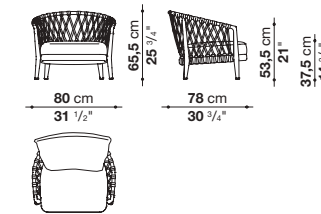

Chair
Sedia

NE61S_I

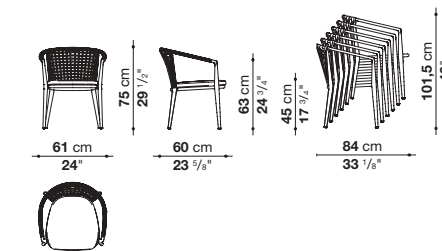

Erica '19

Antonio Citterio • 2019

Inspiration • 106

Frame	die-cast aluminium and extrusions with polyester powder painting
Back upholstery	recycled polyester fibre from PET, cover in water repellent polyester fibre
Back upholstery (British Standard version)	shaped polyurethane of different density, Solutex fibre and visco-elastic polyurethane combination, cover in water repellent polyester fibre
Back upholstery (NE61S_I) (British Standard version)	polyester fibre and polyurethane combination
Seat upholstery	shaped polyurethane, recycled polyester fibre from PET, cover in water repellent polyester fibre
Seat upholstery (British Standard version)	shaped polyurethane, Solutex fibre and visco-elastic polyurethane combination, cover in water repellent polyester fibre (with heat-sealed ribbon)
Seat webbing	polypropylene fibre and synthetic rubber threads
Interlacing	polypropylene fibre braid
Ferrules	thermoplastic material
Waterproof cover cloth	PES fabric coated on one side in PU
Cover	fabric in limited categories (with profile)
Cover (British Standard version)	fabric in limited categories (without profile)

Struttura	pressofusione ed estrusi d'alluminio con verniciatura a polvere poliestere
Imbottitura schienale	fibra di poliestere riciclata da PET, fodera in fibra di poliestere con trattamento idrorepellente
Imbottitura schienale (versione British Standard)	poliuretano sagomato a densità differenziata, combinazione fibra Solutex e poliuretano viscoelastico, fodera in fibra di poliestere con trattamento idrorepellente
Imbottitura schienale (NE61S_I) (versione British Standard)	combinazione fibra di poliestere e poliuretano
Imbottitura sedile	poliuretano sagomato, ecogreen (misto polietilene e poliestere), fodera in fibra di poliestere con trattamento idrorepellente
Imbottitura sedile (versione British Standard)	poliuretano sagomato, combinazione fibra Solutex e poliuretano viscoelastico, fodera in fibra di poliestere con trattamento idrorepellente (con cuciture termosaldate)
Cinghiatura sedile	fibra di polipropilene e fili di gomma sintetica
Intreccio	treccia in fibra di polipropilene
Puntali	materiale termoplastico
Telo di copertura impermeabile	tessuto PES monospalmato su un lato PU
Rivestimento	tessuto in categorie limitate (con profilo)
Rivestimento (versione British Standard)	tessuto in categorie limitate (senza profilo)

Frame and interlacing matching (NE61S_I)

Abbinamento struttura e intreccio

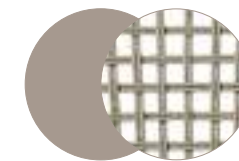

0813T

tortora painted / tortora polypropylene
verniciato tortora / polipropilene naturale

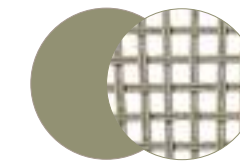

0742S

sage painted / natural polypropylene
verniciato salvia / polipropilene naturale

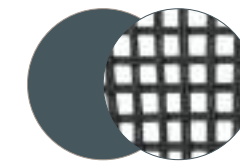

0688A

anthracite painted / anthracite polypropylene
verniciato antracite / polipropilene antracite

Frame and interlacing matching

Abbinamento struttura e intreccio



0828T

tortora painted / tortora polypropylene
verniciato tortora / polipropilene naturale



0702N

sage painted / natural polypropylene
verniciato salvia / polipropilene naturale

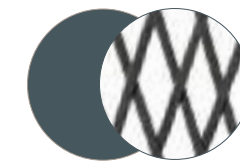

0625G

anthracite painted / anthracite polypropylene
verniciato antracite / polipropilene antracite

Seat and back cushion profile

Profilo cuscino sedile e schienale

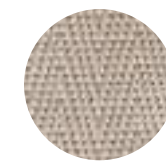

0041E

cream white
bianco panna



0082N

natural
naturale

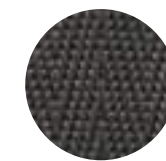

0054G

dark grey
grigio scuro

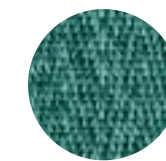

00585A

acquamarine
acquamarina

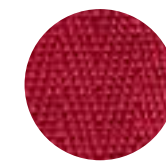

0075R

red
rosso

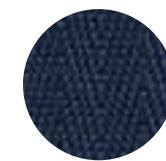

0095B

blue
blu

The colours and materials shown are an indication. Images not in scale.
La tonalità dei colori e dei materiali è indicativa. Immagini non in scala.

Erica '19
Antonio Citterio • 2019
Inspiration • 106

2568715
Salinas

2569400
Ermitage

2569101
Ermitage

2568735
Salinas

2569840
Ermitage



The colours and materials shown are an indication. Images not in scale.
La tonalità dei colori e dei materiali è indicativa. Immagini non in scala.

Product items/Prodotti
Recommended combinations/Abbinamenti suggeriti



2569775 Ermitage	2568715 Salinas	2568735 Salinas	0082N natural profile profilo naturale

0625G anthracite painted anthracite polypropylene verniciato antracite polipropilene antracite



2568715 Salinas	0082N natural profile profilo naturale

0625G anthracite painted anthracite polypropylene verniciato antracite polipropilene antracite



2569400 Ermitage	2568715 Salinas	2568735 Salinas	0082N natural profile profilo naturale

0702N sage painted natural polypropylene verniciato salvia polipropilene naturale



2569840 Ermitage	2568715 Salinas	2568735 Salinas	0095B blue profile profilo blu

0625G anthracite painted anthracite polypropylene verniciato antracite polipropilene antracite



2569400 Ermitage	2498207 Leila	0082N natural profile profilo naturale

0742S sage painted natural polypropylene verniciato salvia polipropilene naturale

The colours and materials shown are an indication. Images not in scale.
La tonalità dei colori e dei materiali è indicativa. Immagini non in scala.

Fat-Fat Outdoor
 Patricia Urquiola • 2019
 Inspiration • 246



The concept of a tray helped create four small outdoor tables with steel frames that give them a lightweight look. These small tables are entirely painted or with tops in porcelain stoneware.

Il tema del vassoio viene ripreso per dar vita a quattro tavolini per esterni il cui aspetto leggero è merito della struttura in acciaio. I tavolini sono proposti interamente verniciati oppure con piano in gres porcellanato.

Frame	steel profile
Top	porcelain stoneware or steel sheet
Tray	steel sheet
Ferrules	thermoplastic material

Struttura	profilati d'acciaio
Piano	gres porcellanato o lamiera d'acciaio
Vassoio	lamiera d'acciaio
Puntali	materiale termoplastico

Small tables

Tavoli

OTF42

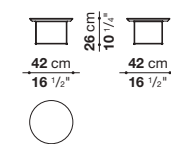

OTF62

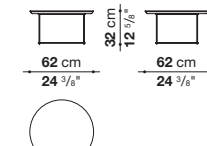

OTF62A

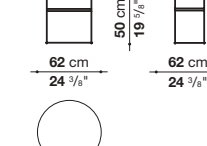

OTF92

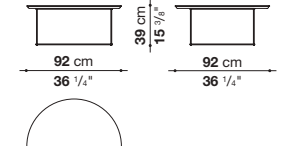

OTF42G

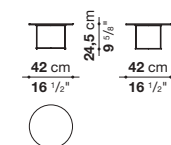

OTF62G

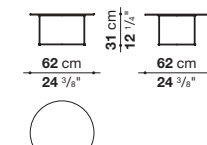

OTF62AG

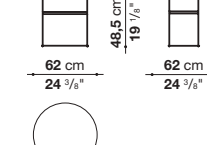

OTF92G

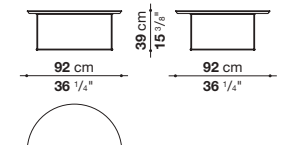

Trays

Vassoi

OF42V

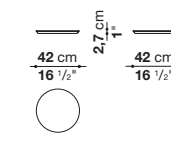

OF62V

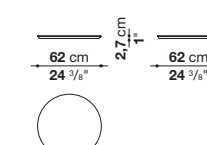

OF92V

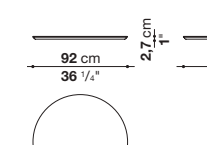

Frame and top
 Struttura e piano

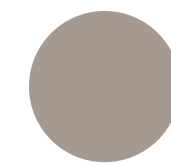

0380T
 tortora painted
 verniciato tortora

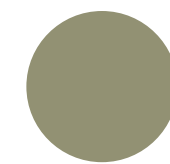

0427S
 sage painted
 verniciato salvia

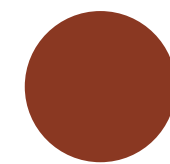

0750A
 clay painted
 verniciato argilla

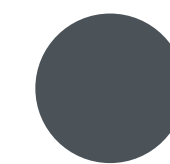

0236B
 anthracite painted
 verniciato antracite



0355N
 anthracite stone
 porcelain stoneware
 gres porcellanato
 pietra antracite

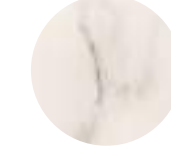

0266B
 white stone
 porcelain stoneware
 gres porcellanato
 bianco

Top (OTF42G-OTF62G-OTF62AG-OTF92G)
 Piano

The colours and materials shown are an indication. Images not in scale. La tonalità dei colori e dei materiali è indicativa. Immagini non in scala.

Fat-Sofa Outdoor

Patricia Urquiola • 2015

Inspiration • 192



The rounded, soft and sinuous shapes of the Fat-Sofa seating system are the base for the outdoor version, characterized by a brand new interlacing design. Its fully padded seat is accompanied by a metal frame backrest that supports the original weave, creating a special play of fullness and emptiness. The large weave pattern, made of tortora coloured twisted polyethylene fibres, makes

Le forme arrotondate, morbide e sinuose, del sistema di sedute Fat-Sofa vengono riprese nella versione da esterni, caratterizzata da un'inedita proposta di intreccio. La seduta completamente imbottita è accompagnata ad uno schienale con struttura in metallo su cui si tesse l'originale intreccio, creando uno speciale gioco di pieni e vuoti. L'intreccio, di effetto grafico e dimensioni macro, realizzato con fibre

the design unique, respecting the designer's idea of lightness, transparency and puts the furnishings in an open "dialogue" with the surrounding environment. Fat-Sofa Outdoor consists of six types, ranging from the linear sofa to a large relax island, from two height variants of the armchair to a range of different sizes of ottomans.

di polietilene ritorte di color tortora, conferisce unicità al progetto, nel rispetto dell'idea della designer di leggerezza, trasparenza e "dialogo" dell'elemento di arredo con l'ambiente circostante. Fat-Sofa Outdoor si compone di sei tipologie, che spaziano dal divano lineare ad un'isola relax di ampie dimensioni, dalla poltrona con schienale in due altezze ad una serie di elementi pouf di diverse dimensioni.

Fat-Sofa Outdoor

Patricia Urquiola • 2015

Inspiration • 192

Sofas

Divani

FA150

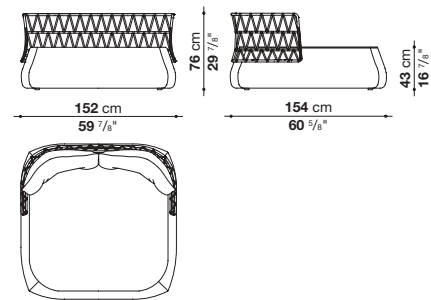

FA230

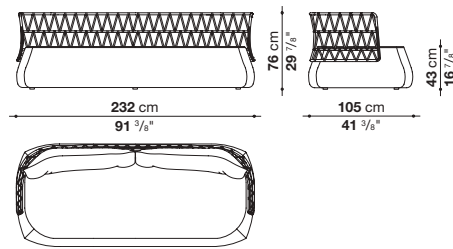

Armchairs

Poltrone

FA91B

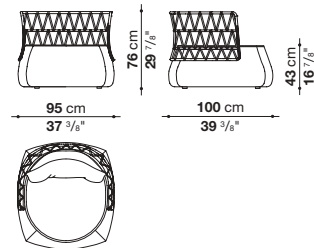

FA91A

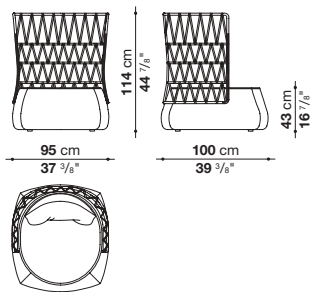

Ottomans

Pouf

FA61P

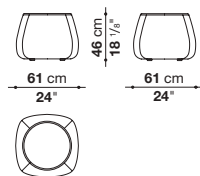

FA76P

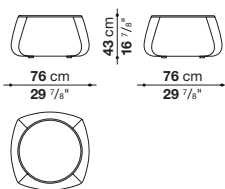

Frame	aluminium with polyester powder painting
Interlacing	polyethylene fibre
Internal frame	tubular steel and steel profiles, polystyrene foam
Internal frame upholstery	Bayfit® (Bayer®) flexible cold shaped polyurethane foam, shaped polyurethane of different density, water repellent polyester fibre cover (with heat-sealed ribbon)
Internal frame (FA61P-FA76P)	polystyrene foam, MDF wood fibre panel with Umidax® high humidity resistance
Internal frame upholstery (FA61P-FA76P)	Bayfit® (Bayer®) flexible cold shaped polyurethane foam, shaped polyurethane, water repellent polyester fibre cover (with heat-sealed ribbon)
Back cushion	polyester fibre, cover in water repellent polyester fibre
Bottom base	100% polyamide fabric coated PVC, PVC trimming
Feet	thermoplastic material
Waterproof cover cloth	PES fabric coated on one side in PU
Cover	fabric in limited categories

Struttura	alluminio con verniciatura a polvere poliesteri
Intreccio	fibra di polietilene
Telaio interno	tubolari e profilati d'acciaio, polistirolo espanso
Imbottitura telaio interno	schiuma di poliuretano flessibile a freddo Bayfit® (Bayer®), poliuretano sagomato a densità differenziata, fodera in fibra di poliesteri con trattamento idrorepellente (con cuciture termosaldate)
Telaio interno (FA61P-FA76P)	polistirolo espanso, pannello in fibra di legno MDF ad alta resistenza all'umidità Umidax®
Imbottitura telaio interno (FA61P-FA76P)	schiuma di poliuretano flessibile a freddo Bayfit® (Bayer®), poliuretano sagomato, fodera in fibra di poliesteri con trattamento idrorepellente (con cuciture termosaldate)
Cuscino schienale	fibra di poliesteri, fodera in fibra di poliesteri con trattamento idrorepellente
Fondo	tessuto 100% poliammide spalmato PVC, guarnizione in PVC
Piedini	materiale termoplastico
Telo di copertura impermeabile	tessuto PES monospalmato su un lato PU
Rivestimento	tessuto in categorie limitate

Interlacing

Intreccio

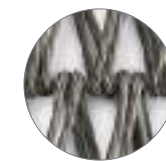

0612T
tortora polyethylene
polietilene tortora

The colour and material shown are an indication. Image not in scale.
La tonalità del colore e del materiale è indicativa. Immagine non in scala.

Frank Outdoor

Antonio Citterio • 2019

Inspiration • 258



This outdoor ottomans have contrasting profiles matched to colourful outdoor fabrics to provide a touch of colour to your outdoor furnishings.

Pouf per esterni che si caratterizzano per l'abbinamento di profili a contrasto abbinati a colorati tessuti outdoor e che donano una nota di vitale agli arredi per esterno.

Internal frame	tubular steel and steel profiles
Upholstery	Bayfit® flexible cold shaped polyurethane foam, water repellent polyester fibre cover (with heat-sealed ribbon)
Ferrules	thermoplastic material
Waterproof cover cloth	PES fabric coated on one side in PU
Cover	fabric in limited categories (with profile)

Telaio interno	tubolari e profilati d'acciaio
Imbottitura	schiuma di poliuretano flessibile a freddo Bayfit®, fodera in fibra di poliestere con trattamento idrorepellente (con cuciture termosaldate)
Puntali	materiale termoplastico
Telo di copertura impermeabile	tessuto PES monospalmato su un lato PU
Rivestimento	tessuto in categorie limitate (con profilo)

Ottoman

Pouf

OF58P

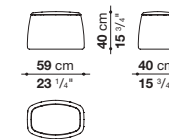

Profile

Profilo

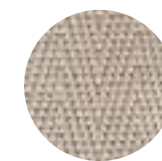

0041E
cream white
bianco panna

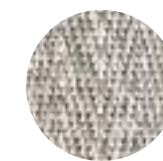

0082N
natural
naturale

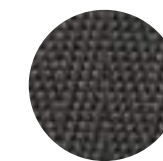

0054G
dark grey
grigio scuro

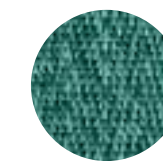

00585A
acquamarine
acquamarina

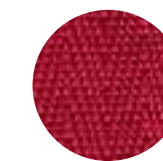

0075R
red
rosso

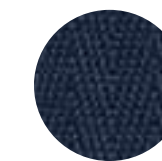

0095B
blue
blu

The colours and materials shown are an indication. Images not in scale.
La tonalità dei colori e dei materiali è indicativa. Immagini non in scala.

Ginepro

Antonio Citterio • 2020
Inspiration • 164



The Ginepro table is made with an anthracite painted aluminum structure and a Serpentine stone top extremely durable and precious as the linear and timeless style.

Il tavolo Ginepro è realizzato con struttura in alluminio verniciato antracite e piano in pietra Serpentino estremamente durevole e pregiata in linea con lo stile lineare e senza tempo.

With its two shapes (round and rectangular with rounded corners) and four dimensions, it lends itself to be placed in different outdoor environments: terraces, verandas, patios and gardens.

Con le sue due forme (rotondo e rettangolare con angoli smussati) e quattro dimensioni, si presta ad essere collocato in ambienti differenti: terrazze, verande, patio e giardini.

Ginepro

Antonio Citterio • 2020

Inspiration • 164

Tables
Tavoli

TGS105R

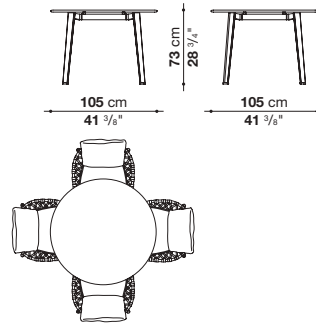

TGS140R

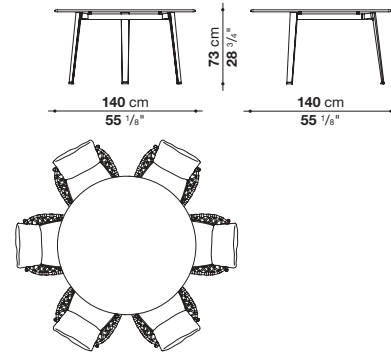

TGS190

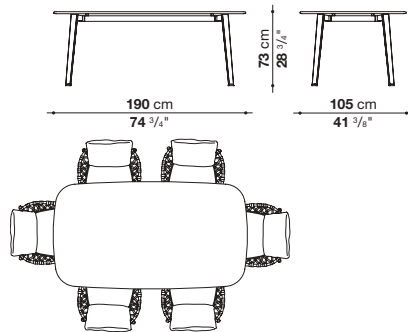

TGS250

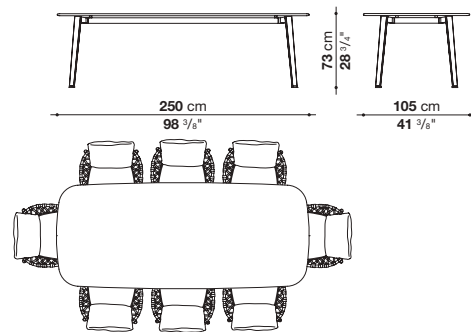

Ginepro

Antonio Citterio

Product Specifications 109

Top	Serpentine stone	Piano	pietra Serpentino
Frame	die-cast aluminium and extrusions with polyurethane painting	Struttura	fusione ed estrusi d'alluminio con verniciatura poliuretanica
Ferrules	thermoplastic material	Puntali	materiale termoplastico
Waterproof cover cloth	PES fabric coated on one side in PU	Telo di copertura impermeabile	tessuto PES monospalmato su un lato PU

Top
Piano

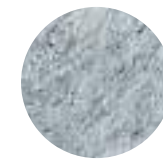

040SS
Serpentine stone
pietra Serpentino

Frame
Struttura

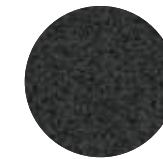

0236B
anthracite painted
verniciato antracite

The colours and materials shown are an indication. Images not in scale.
La tonalità dei colori e dei materiali è indicativa. Immagini non in scala.

Ginestra

Antonio Citterio • 2017

Inspiration • 178



Collection of large rectangular and round dining tables featuring natural teakwood structural details and designed tops, studied to match central inserts made of Calacatta white porcelain stoneware. The same collection features a chair, always in natural teakwood, with sinuous harmonious lines that are clearly inspired by northern trends. It is characterised by an interlacing in polypropylene fibre that is ideal for outdoor use. Colours are chosen to match natural teakwood with a beige interlacing. Comfort is guaranteed by seat and back cushions.

Collezione di tavoli da pranzo rettangolari e rotondi di grandi dimensioni caratterizzati da dettagli strutturali e disegni dei top realizzati in teak naturale che si abbinano ad inserti centrali realizzati in gres porcellanato bianco Calacatta. Della stessa serie una sedia, sempre in teak naturale, dalle linee sinuose e fluide di chiara ispirazione nordica, caratterizzata da un intreccio di nastri in tessuto sintetico adatto all'utilizzo outdoor. Lo studio cromatico ha previsto l'abbinamento del teak naturale ad un intreccio con nastro di colore beige. Il comfort è garantito da un cuscino sedile e schienale.

Ginestra

Antonio Citterio • 2017

Inspiration • 178

Tables

Tavoli

GN220T

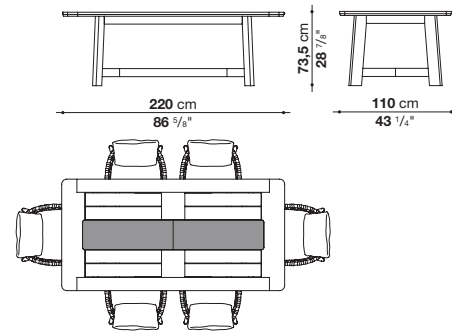

GN280T

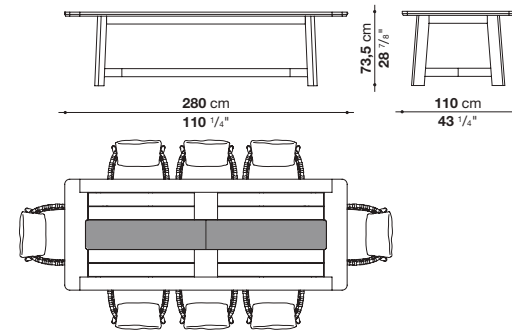

GN180TR

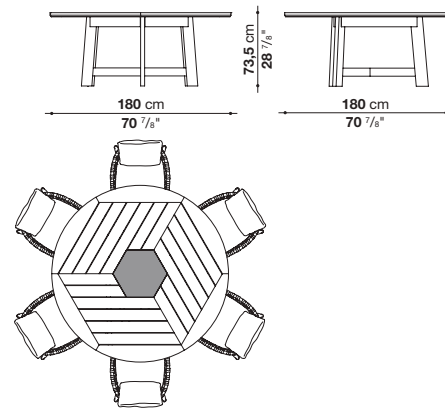

Chair

Sedia

GN60

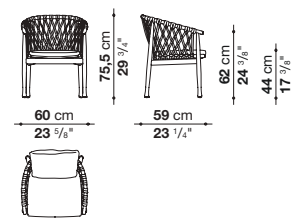

Frame and top (GN280T-GN220T-GN180TR)	solid wood
Back upholstery	polyester fibre and polyurethane combination
Seat upholstery	shaped polyurethane, Solutex fibre and visco-elastic polyurethane combination, cover in water repellent polyester fibre
Interlacing	polypropylene fibre braid
Top section	porcelain stoneware
Ferrules	thermoplastic material
Waterproof cover cloth	PES fabric coated on one side in PU
Cover	fabric in limited categories

Struttura e piano (GN280T-GN220T-GN180TR)	legno massello
Imbottitura schienale	combinazione fibra di poliestere e poliuretano
Imbottitura sedile	poliuretano sagomato, combinazione fibra Solutex e poliuretano viscoelastico, fodera in fibra di poliestere con trattamento idrorepellente
Intreccio	treccia in fibra di polipropilene
Inserto piano	gres porcellanato
Puntali	materiale termoplastico
Telo di copertura impermeabile	tessuto PES monospalmato su un lato PU
Rivestimento	tessuto in categorie limitate

Tables frame and top

Struttura e piano tavoli



0456T
natural teakwood
teak naturale

Table top section

Inserto piano tavolo



0301B
Calacatta white porcelain stoneware
gres porcellanato bianco Calacatta

Interlacing (GN60)

Intreccio



0312B
beige polypropylene
polipropilene beige

Gio

Antonio Citterio • 2016

Inspiration • 148



Gio, designed by Antonio Citterio, is the series with a contemporary classic accent dedicated to living in the open air. A complete range of sofas, end units, chaise longue, sunbeds, armchairs, chairs, tables and complements which have been developed from solid teak structures with a special antique grey finish, which gives the wood a particular lived-in aspect and silver-grey reflective quality.

Al vivere all'aria aperta è dedicata Gio, la serie dall'accento classico contemporaneo disegnata da Antonio Citterio. Una famiglia completa di divani, elementi terminali, chaise longue, lettini, poltrone, sedie, tavoli e complementi che si sviluppano a partire da strutture in massello di teak nella speciale finitura antique grey, che conferisce al legno un particolare aspetto vissuto con riflessi grigio argento.

The various types of sofas, end units and chaise longue can be assembled to form linear, corner and peninsula seating. All elements have a basic structure of wooden slats where backrests and armrests, characterised by and interlacing of tortora ribbons, can be easily inserted.

Da un punto di vista formale le varie tipologie di divani, elementi terminali e chaise longue, tutti accostabili per formare sedute lineari, angolari e a penisola, prevedono una struttura di base a doghe di legno sulla quale si innestano telai schienale e braccioli caratterizzati dall'intreccio di nastri di colore tortora.

Gio

Antonio Citterio • 2016
Inspiration • 148



The seats are equipped with seat and back cushions which makes the Gio series particularly cosy and comfortable, and offer exclusive colour combinations.

Le sedute sono completate da cuscini sedile e schienale che rendono Gio particolarmente accogliente e confortevole e offrono esclusivi abbinamenti cromatici.



To ensure a better insulation from the weather, all the padded elements have a polyester cover with waterproof treatment, and the fabrics are certified for resistance to weathering, UV rays, chlorine and sea spray.

Per garantire un migliore isolamento dalle intemperie, tutte le imbottiture sono rivestite con una fodera di poliestere con trattamento waterproof, mentre i tessuti sono certificati per resistenza agli agenti atmosferici, ai raggi UV, all'acqua clorata e alla salsedine.

Gio

Antonio Citterio • 2016

Inspiration • 148

The particular type of structure of Gio allows for easily disassemble the various components, so to reduce the space needed to store the products in winter.

Questa particolare tipologia di struttura consente di disassemblare in maniera molto semplice i vari componenti, riducendo così i volumi nel caso in cui si renda necessario stoccare il prodotto nel periodo invernale.



Sofas

Divani

G0203

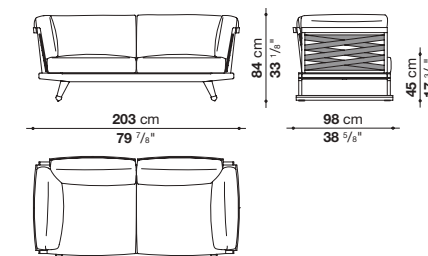

G0238

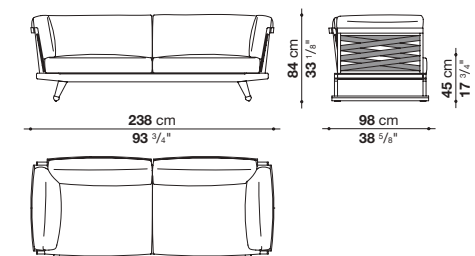

Central elements

Elementi centrali

G0192C

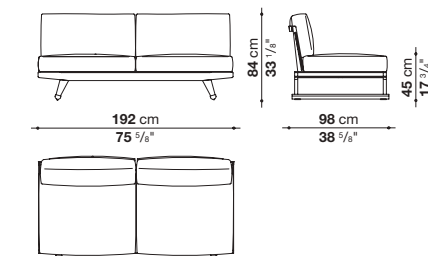

G0227C

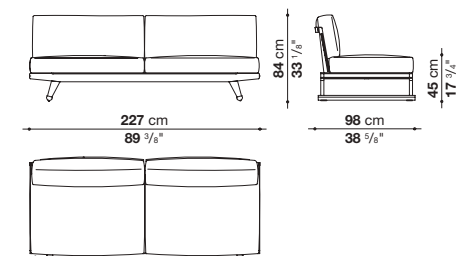

* G0192CD

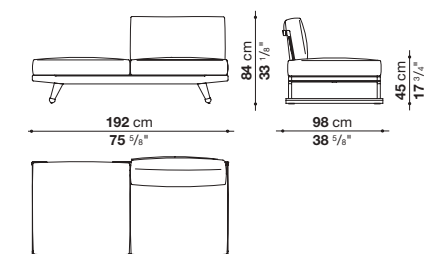

* G0227CD

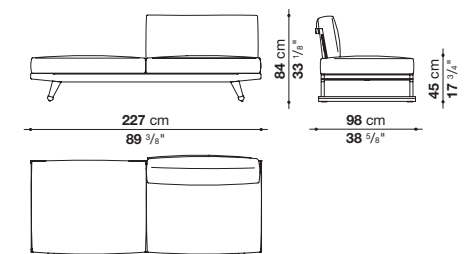

Gio

Antonio Citterio • 2016

Inspiration • 148

Terminal elements

Elementi terminali

* G0197TD

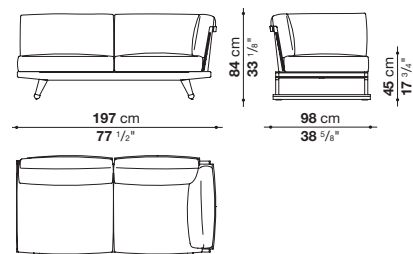

* G0233TD

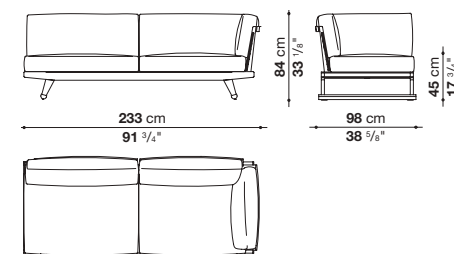

Chaise longue

Chaise longue

* G0203LD

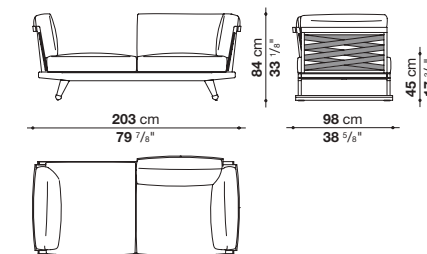

* G0238LD

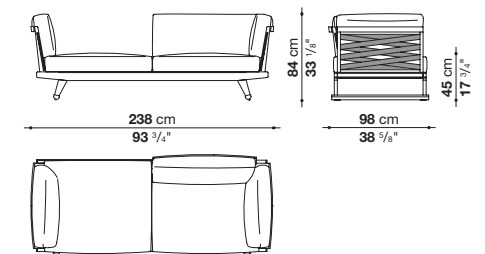

Corner elements

Elementi angolari

G0197AD

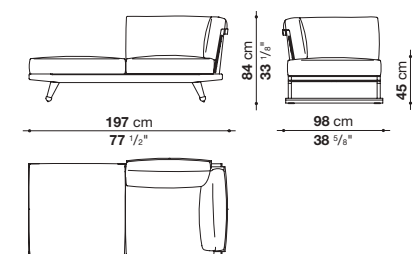

G0233AD

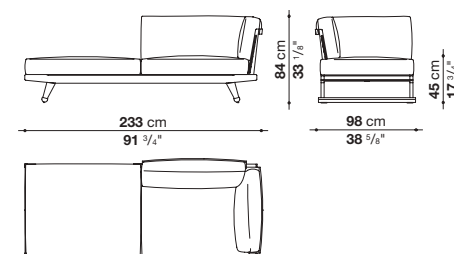

G0203L

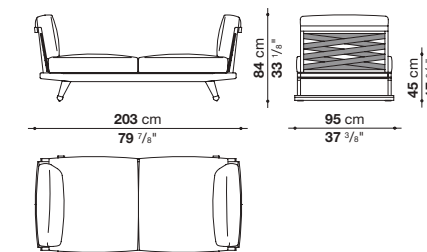

G0238L

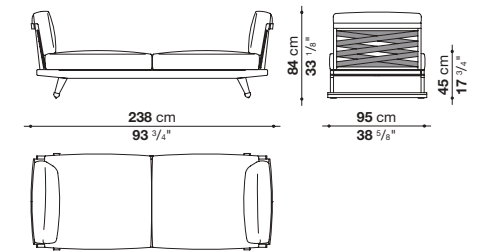

Chaise longue

Chaise longue

* G0197LD

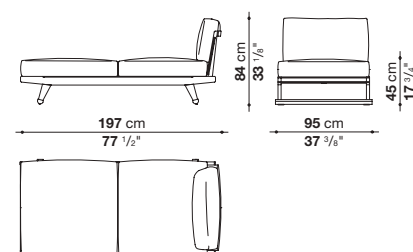

* G0233LD

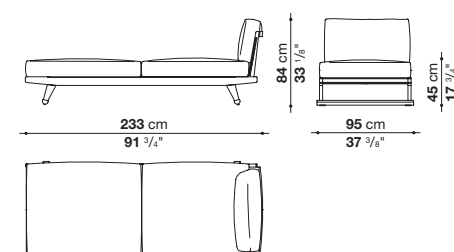

Sunbed with adjustable back

Lettino con schienale regolabile

G0200L

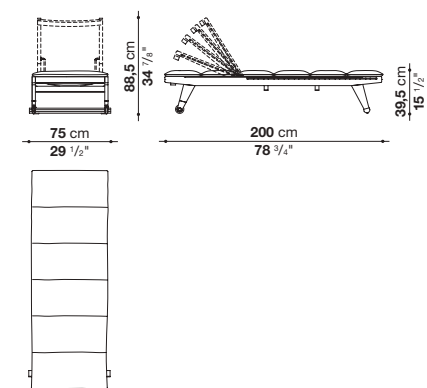

Armchair

Poltrona

G064

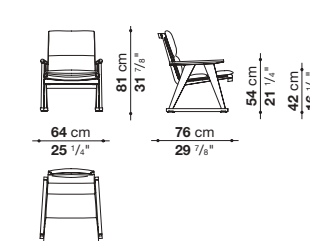

Chair

Sedia

G058

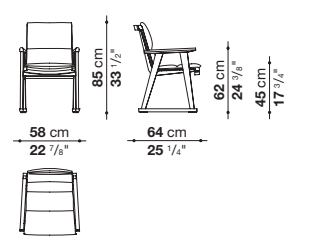

* Elements available in right and left version. / Elementi disponibili nella versione destra e sinistra.
The colours and materials shown are an indication. Images not in scale.
La tonalità dei colori e dei materiali è indicativa. Immagini non in scala.

* Elements available in right and left version. / Elementi disponibili nella versione destra e sinistra.
The colours and materials shown are an indication. Images not in scale.
La tonalità dei colori e dei materiali è indicativa. Immagini non in scala.

Gio

Antonio Citterio • 2016

Inspiration • 148

Benches

Panche

G065P

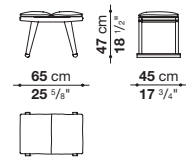

G0130P

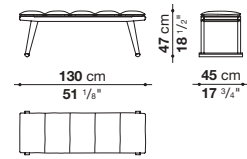

Small tables

Tavolini

TG06

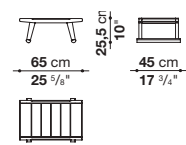

TG09

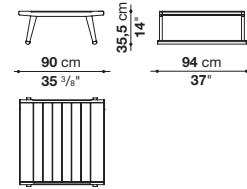

TG012

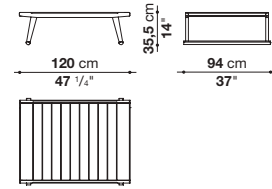

TG018

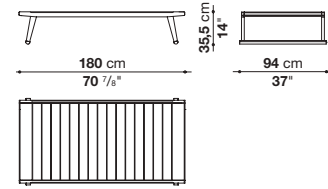

Low tables

Tavoli bassi

Tables

Tavoli

TG0220

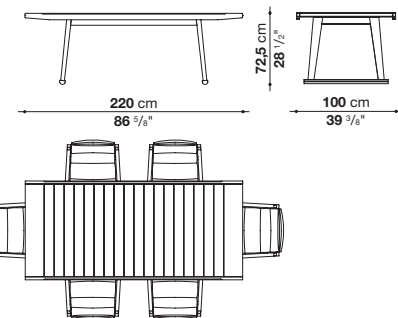

TG0280

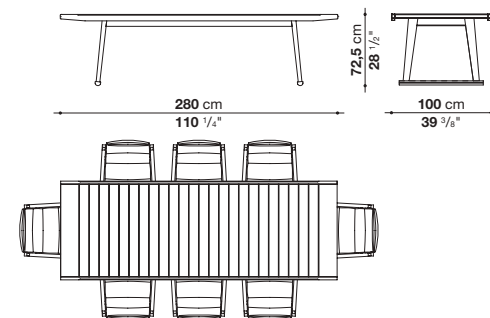

Frame and top	solid wood
Webbing	polypropylene
Upholstery	shaped polyurethane of different density, combination of Solutex fibre and visco-elastic polyurethane, cover in water repellent polyester fibre
Upholstery (G05S-G064-G0200L-G065P-G0130P)	high density polyester fibre
Reclining mechanism and zipper (G0200L)	electro polished stainless steel
Wheels (G0200L)	co-moulded thermoplastic material
Wheel supports (G0200L)	die-cast aluminium
Ferrules	thermoplastic material
Waterproof cover cloth	PES fabric coated on one side in PU

Struttura e piano	legno massello
Cinghiatura	polipropilene
Imbottitura	poliuretano sagomato a densità differenziata, combinazione fibra Solutex e poliuretano viscoelastico, fodera in fibra di poliestere con trattamento idrorepellente
Imbottitura (G05S-G064-G0200L-G065P-G0130P)	fibra di poliestere ad alta densità
Meccanismo reclinabile e cerniera (G0200L)	acciaio inox elettrolucidato
Ruote (G0200L)	materiale termoplastico co-stampato
Sostegno ruote (G0200L)	alluminio pressofuso
Puntali	materiale termoplastico
Telo di copertura impermeabile	tessuto PES monospalmato su un lato PU

Frame and top

Struttura e piano

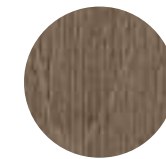

0492T
antique grey teakwood
teak antique grey

Webbing

Cinghiatura

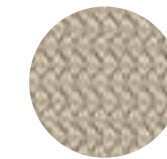

0113B
tortora polypropylene
polipropilene tortora

The colours and materials shown are an indication. Images not in scale.
La tonalità dei colori e dei materiali è indicativa. Immagini non in scala.

Hospes

B&B Italia CR&S 2020

Inspiration • 240



Hospes is a dynamic complement that can be used in different ways and fits perfectly with different product families. Made in two sizes and three colors – overseas blue, stone, anthracite - it is based on a robust aluminum frame covered with an interlacing of waterproof ropes. On top, the interlacing hides a padding that provides support and comfort.

Hospes è una seduta estremamente versatile, che trova il suo luogo ideale in ogni ambiente. Un complemento dinamico che può essere utilizzato in modi diversi e si sposa perfettamente con diverse famiglie di prodotto. Realizzato in due dimensioni e tre colori - blu oltremare, sasso e antracite - si basa su un robusto telaio in alluminio rivestito con un intreccio di corde impermeabili. Nella parte superiore l'intreccio nasconde un'imbottitura che dona sostegno e comfort.

Internal frame	tubular aluminium and aluminium profiles
Upholstery	shaped polyurethane
Interlacing	polypropylene fibre braid
Ferrules	thermoplastic material

Telaio interno	tubolari e profilati d'alluminio
Imbottitura	poliuretano sagomato
Intreccio	treccia in fibra di polipropilene
Puntali	materiale termoplastico

Ottomans

Pouf

HE1

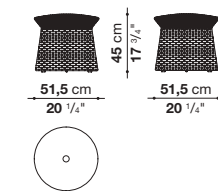

HE2

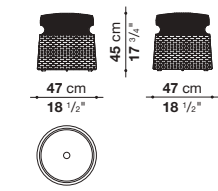

Interlacing

Intreccio

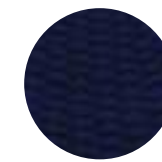

0835B
overseas blue polypropylene
blu oltremare polipropilene

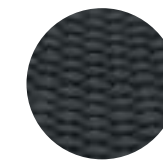

0133A
anthracite polypropylene
antracite polipropilene

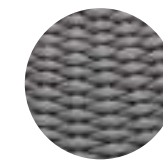

0244S
stone polypropylene
sasso polipropilene

The product is not available in U.K. market (British Standard) and California (TB117) / Il prodotto non è disponibile nel mercato UK (British Standard) and California (TB117). The colours and materials shown are an indication. Images not in scale. / La tonalità dei colori e dei materiali è indicativa. Immagini non in scala.

Husk Outdoor

Patricia Urquiola • 2011

Inspiration • 230



Comfort and eco-sustainability are the key words for describing Husk Outdoor, designed by Patricia Urquiola. The collection is a tribute to softness, and just looking at these pieces is restful. Husk Outdoor features a hard shell made of Hirek®, a special plastic formed from recycled and recyclable polymers, and a set of soft cushions. The shell is white, while the fixed seat support is available painted in five colours. Cushions come in two versions, with larger sizes on the seat or on the back.

Comfort ed ecosostenibilità le parole chiave delle poltrone Husk Outdoor disegnate da Patricia Urquiola. La collezione è un inno alla morbidezza e invita al riposo già al primo sguardo. Husk Outdoor si caratterizza per una scocca rigida in Hirek®, una speciale plastica formata da polimeri riciclati e riciclabili, ed una serie di cuscini soffici. Bianco è il colore della scocca, mentre il supporto fisso è disponibile verniciato in cinque varianti. Due le versioni della cuscinatura, a scelta di dimensioni più generose sulla seduta o sullo schienale.

The dining chair version completes the Husk Outdoor collection, which meets a variety of size and functional needs.

The shell is available only in white; the four legs are in white or black painted metal.

The Husk Outdoor collection also includes two small tables: one with three spokes \varnothing 45 cm, available in the same colour variants as the armchair bases; the other with four spokes \varnothing 62,5 cm, already proposed in indoor spaces, joins the Outdoor collection with single colour versions painted white or black.

La tipologia sedia da pranzo completa la proposta Husk Outdoor ed è in grado di rispondere a necessità diverse per dimensione degli spazi e per funzioni. Unico è il colore della scocca, il bianco; le quattro gambe sono in metallo verniciato bianco oppure nero.

Della collezione Husk Outdoor fanno parte anche due tavolini: uno a tre razze \varnothing 45 cm, disponibile nelle stesse varianti di colore dei basamenti delle poltrone; l'altro a quattro razze \varnothing 62,5 cm, già proposto per spazi indoor, entra a far parte della collezione Outdoor con le versioni monocolori verniciato bianco o nero.

Husk Outdoor

Patricia Urquiola • 2011

Inspiration • 230

Armchairs

Poltrone

H2

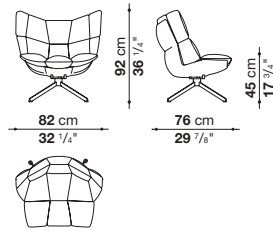

H4

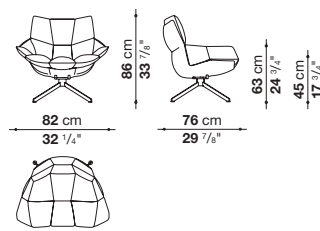

Ottoman

Pouf

HP1

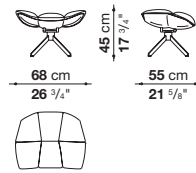

Small tables

Tavolini

HT

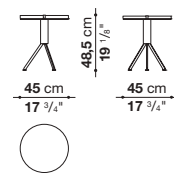

HT062

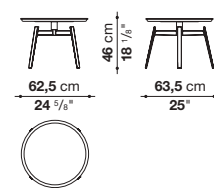

Tray

Vassoio

HT062V

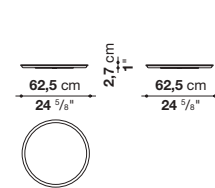

Shell	Hirek® plastic material	Scocca	materiale plastico Hirek®
Upholstery	polyester fibre, cover in water repellent polyester fibre	Imbottitura	fibra di poliestere, fodera in fibra di poliestere con trattamento idrorepellente
Base-frame	aluminium profiles with polyester powder painting	Basamento	profilati d'alluminio con verniciatura a polvere poliestere
Top (HT)	aluminium sheet with polyester powder painting	Piano (HT)	lamiera d'alluminio con verniciatura a polvere poliestere
Top and tray (HT062-HT062V)	steel sheet with polyester powder painting	Piano e vassoio (HT062-HT062V)	lamiera d'acciaio con verniciatura a polvere poliestere
Support frame (HT062)	steel sheet and die-cast aluminium with polyester powder painting	Struttura di sostegno (HT062)	lamiera d'acciaio e fusione d'alluminio con verniciatura a polvere poliestere
Ferrules (HT062)	plastic material and stainless steel	Puntali	materiale plastico e acciaio inossidabile
Ferrules (HT062)	plastic material	Puntali (HT062)	materiale plastico
Waterproof cover cloth	PES fabric coated on one side in PU	Telo di copertura impermeabile	tessuto PES monospalmato su un lato PU
Cover	fabric in limited categories	Rivestimento	tessuto in categorie limitate

Shell

Scocca

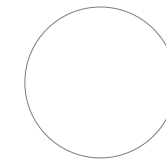

0010B
white Hirek®
Hirek® bianco

Small table base-frame and tray (HT062 - HT062V)

Basamento e vassoio tavolino

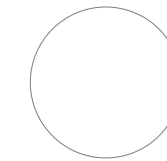

09010
white painted
verniciato bianco

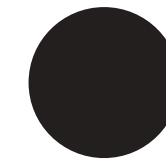

01510
black painted
verniciato nero

Seatings base-frame and small table top (HT)

Basamento sedute e piano tavolino

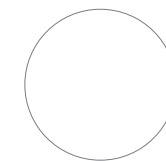

09010
white painted
verniciato bianco

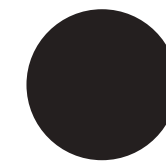

01510
black painted
verniciato nero

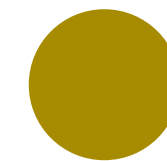

04510
acid green painted
verniciato verde acido

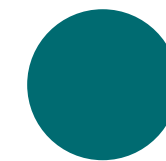

08110
light blue painted
verniciato azzurro

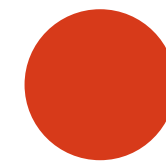

05710
orange painted
verniciato arancio

The colours and materials shown are an indication. Images not in scale.
La tonalità dei colori e dei materiali è indicativa. Immagini non in scala.

Husk Outdoor

Patricia Urquiola • 2011

Inspiration • 230

Shell	high density polyurethane resin (Baydur®)
Upholstery	polyester fibre, needle polyester fibre section
Support frame	die-cast aluminium with polyester powder painting
Ferrules	plastic material
Waterproof cover cloth	PES fabric coated on one side in PU
Cover	fabric in limited categories

Scocca	resina poliuretanic ad alta densità (Baydur®)
Imbottitura	fibra di poliestere, inserto in fibra di poliestere agugliato
Struttura di sostegno	fusione d'alluminio con verniciatura a polvere poliestere
Puntali	materiale plastico
Telo di copertura impermeabile	tessuto PES monospalmato su un lato PU
Rivestimento	tessuto in categorie limitate

Chair

Sedia

HK1N

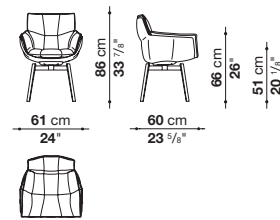

Shell

Scocca

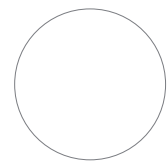

0020B
white Baydur®
Baydur® bianco

Support frame

Struttura di sostegno

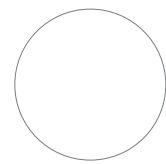

09010
white painted
verniciato bianco

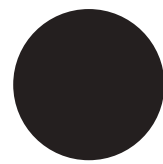

01510
black painted
verniciato nero

The colours and materials shown are an indication. Images not in scale.
La tonalità dei colori e dei materiali è indicativa. Immagini non in scala.

Product items/Prodotti

Recommended combinations/Abbinamenti suggeriti



08110
light blue
painted
verniciato
azzurro



09010
white
painted
verniciato
bianco



2433100
Eleo



0010B
white Hirek®
Hirek® bianco



09010
white
painted
verniciato
bianco



2433570
Eleo



04510
acid green
painted
verniciato
verde acido



2433200
Eleo



0010B
white Hirek®
Hirek® bianco



09010
white
painted
verniciato
bianco



2433810
Eleo



0010B
white Hirek®
Hirek® bianco



09010
white
painted
verniciato
bianco



2433200
Eleo



0010B
white Baydur®
Baydur® bianco



09010
white
painted
verniciato
bianco



01510
black
painted
verniciato
nero



08110
light blue
painted
verniciato
azzurro



09010
white
painted
verniciato
bianco



04510
acid green
painted
verniciato
verde acido



05710
orange
painted
verniciato
arancio

The colours and materials shown are an indication. Images not in scale.
La tonalità dei colori e dei materiali è indicativa. Immagini non in scala.

Hybrid

Antonio Citterio • 2020

Inspiration • 62



After the great success of Ribes, Antonio Citterio developed some design ideas behind it and created Hybrid, an innovative new system of modular seating elements that it is so versatile it can be arranged into an almost infinite number of combinations.

The key role of the textile dimension stands out immediately, with upholsteries that cover completely the generous padding, the absolute protagonist. These are typical elements of indoor furnishings, which find with Hybrid an outdoor interpretation.

Hence the name of the collection, which is proposed as a real link between the inside and the outside of the house.

Hybrid represents in fact the perfect furnishing element for climates and spaces that are defined by a continuous blend of inside and outside environments, with rooms that open to an en-plein-air dimension, and for living spaces integrated into terraces and gardens. The combination of opposites happens not only visually, but also through the sense of touch. Hybrid guarantees in fact the typical comfort of traditional upholstered furniture for interiors, thanks to a new type of mattress seat conceived for outdoor furnishing.

Dopo il grande successo di Ribes, Antonio Citterio ne sviluppa alcuni spunti progettuali e nasce Hybrid, un nuovo sistema di sedute modulare ad alto tasso di innovazione, estremamente versatile e dalla componibilità pressoché infinita. Immediatamente balza all'occhio il ruolo chiave della dimensione tessile, che riveste completamente una generosa imbottitura, assoluta protagonista. Si tratta di elementi tipici dell'indoor, che con Hybrid arrivano con determinazione nell'outdoor. Da qui il nome della collezione, che si propone come vero e proprio anello di congiunzione tra l'interno e l'esterno della casa. Hybrid rappresenta infatti il perfetto elemento d'arredo per climi e spazi che si definiscono per la continuità tra dentro e fuori, ambienti naturalmente aperti a una dimensione en-plein-air, ma anche per spazi living integrati a terrazze o giardini. L'unione degli opposti non avviene soltanto attraverso la vista, bensì anche col tatto. Hybrid garantisce infatti il comfort tipico dei tradizionali imbottiti da interni, grazie a una seduta a materasso, estremamente soffice e accogliente, inedita per l'arredamento da esterni. La cuscinatura è infatti realizzata con materiale per imbottiture a diversa densità, studiato per accogliere



The cushions are actually made with paddings with different densities, carefully designed to pleasantly accommodate the body and support it at the same time, without sinking. The supporting structures are almost invisible, and the seat seems to float a few centimeters above the floor. The solid base is formed by a frame in extruded aluminum painted in the colours sage, clay and anthracite, and is completed by a platform with fiberglass slats. The backrest conceals an aluminum structure, covered with soft polyurethane, which is in turn covered with a padded sheath, completed with a cover in waterproof fabric. The platform is available in eight sizes and two depths, while the armrest and backrest come in two heights. To guarantee further comfort to the deeper seat, the low backrest can be raised with an additional headrest cushion. Additional cushions in various sizes enrich the range, offering countless design and chromatic solutions. The Hybrid collection also includes a series of new outdoor fabrics made with mélange polypropylene yarn in five colour variants that are accented by refined trims. Choices that confirm a decisive and elegant presence for interiors and outdoor spaces.

piacevolmente il corpo e sostenerlo allo stesso tempo, senza sprofondare. Le strutture portanti sono pressoché invisibili e la seduta sembra fluttuare a pochi centimetri dal pavimento. La base è formata da una solida struttura a cornice in estruso di alluminio verniciato nei colori salvia, argilla e antracite, completata da un pianale con doghe in fibra di vetro. Lo schienale nasconde una struttura di alluminio, rivestita di poliuretano morbido, a sua volta rivestito con una guaina imbottita, completata con un rivestimento in tessuto impermeabile. La piattaforma è disponibile in otto misure e due profondità, mentre il bracciolo e lo schienale prevedono due altezze. Per garantire ulteriore comodità alla seduta più profonda, lo schienale basso si può innalzare con un cuscino poggiatesta supplementare. Cuscini aggiuntivi in varie dimensioni arricchiscono la gamma, offrendo innumerevoli soluzioni progettuali e cromatiche. Fanno parte della collezione Hybrid una serie di nuovi tessuti outdoor realizzati con filato di polipropilene mélange in cinque varianti di colore che si sposano con raffinate bordature. Scelte che confermano una presenza decisa ed elegante per interni ed esterni.

Hybrid

Antonio Citterio • 2020

Inspiration • 62



All the objects in the Hybrid collection can be dismantled completely. At the end of the life cycle, each individual element can be separated and disposed of following the path best suited to each material. The particular type of structure of Hybrid allows for easily disassemble the various components, so to reduce the space needed to store the products in winter.

Tutti gli oggetti della collezione Hybrid sono completamente disassemblabili. Alla fine del ciclo di vita ogni singolo elemento si potrà separare e smaltire seguendo il percorso più adatto a ogni materiale. La sua particolare struttura consente di disassemblare in maniera molto semplice i vari componenti, riducendo così i volumi nel caso in cui si renda necessario stoccare il prodotto nel periodo invernale.

Sofas (depth 90 cm.)

Divani (prof. 90 cm.)

9HY222

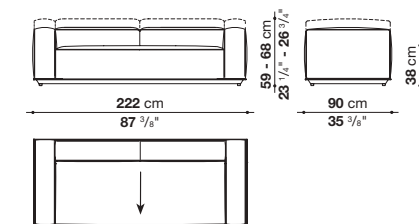

9HY310

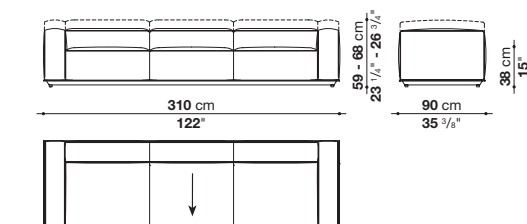

Central elements (depth 90 cm.)

Elementi centrali (prof. 90 cm.)

9HY178C

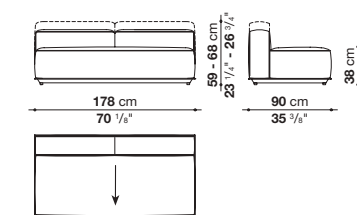

9HY266C

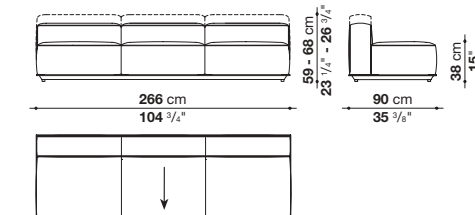

Terminal elements (depth 90 cm.)

Elementi terminali (prof. 90 cm.)

9HY200T_1

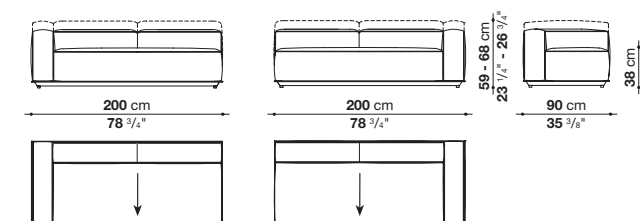

9HY200T_2

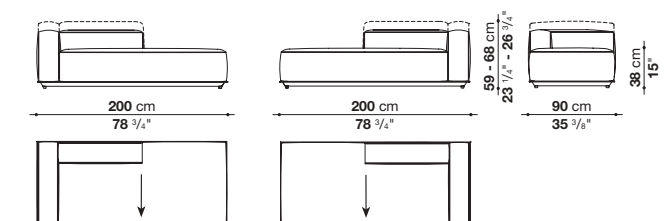

Hybrid

Antonio Citterio • 2020

Inspiration • 62

Corner elements (depth 90 cm.)
Elementi angolari (prof 90 cm.)

9HY178A_1

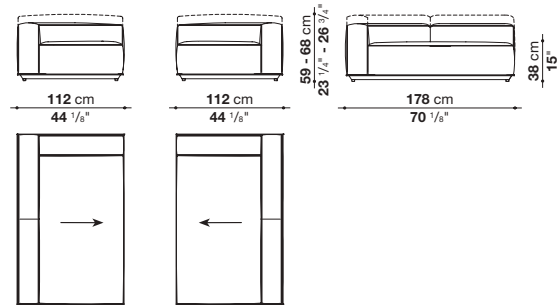

9HY178A_2

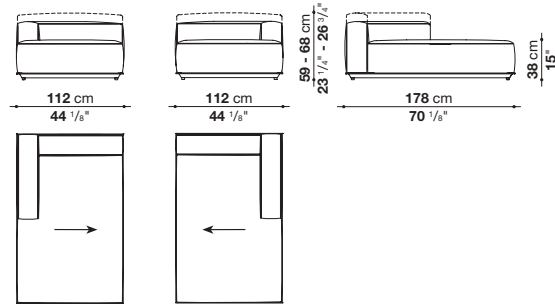

Bench (depth 90 cm.)
Panca (prof. 90 cm.)

9HY178PA

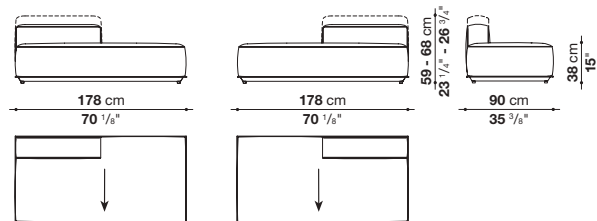

Central elements (depth 112 cm.)
Corner terminali (prof. 112 cm.)

Central elements (depth 112 cm.)
Corner terminali (prof. 112 cm.)

HY178C

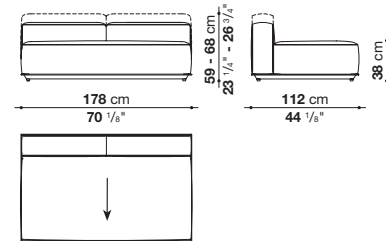

HY266C

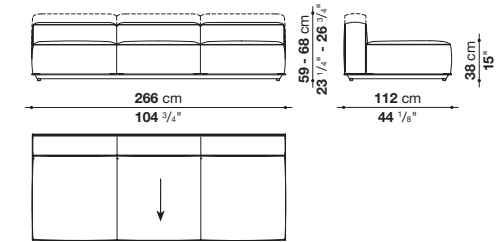

Terminal elements (depth 112 cm.)
Elementi terminali (prof. 112 cm.)

HY200T_1

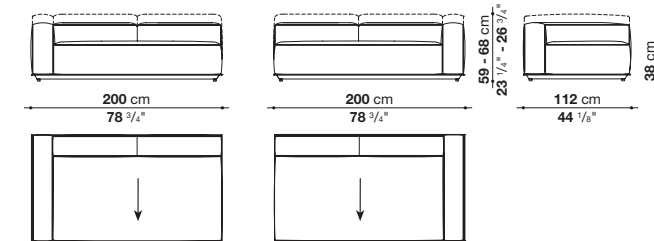

HY200T_2

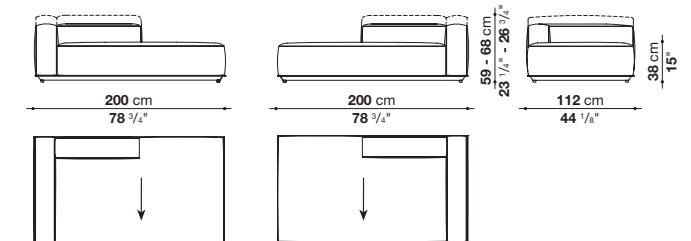

Corner elements (depth 112 cm.)
Elementi angolari (prof. 112 cm.)

HY222A_1

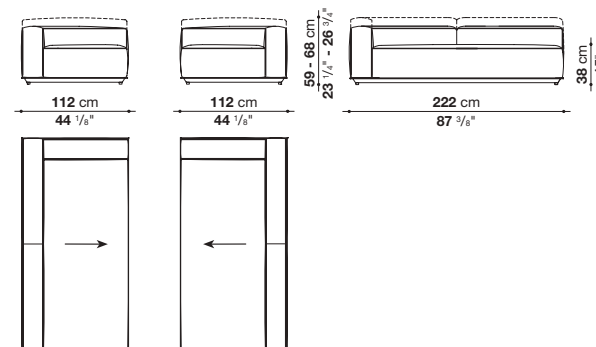

HY222A_2

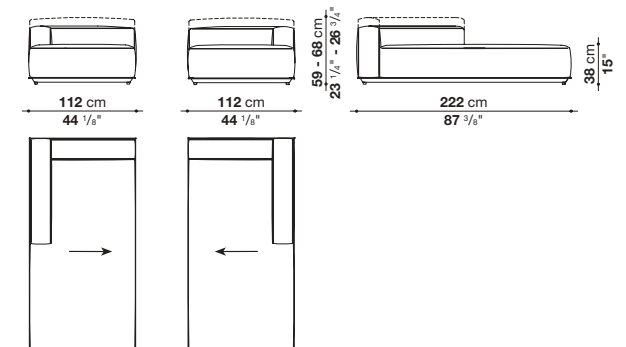

Hybrid

Antonio Citterio • 2020

Inspiration • 62

Bench (depth 112 cm.)
Panca (prof. 112 cm.)

HY178APA

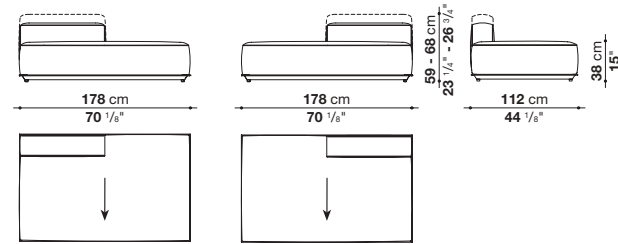

Chaise longue
Chaise longue

HY134L

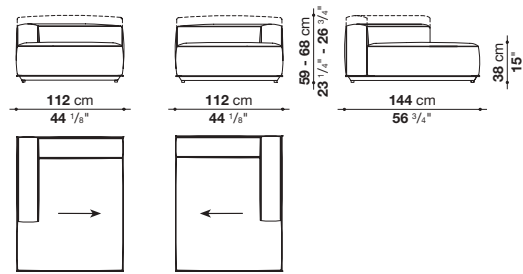

HY134L_2

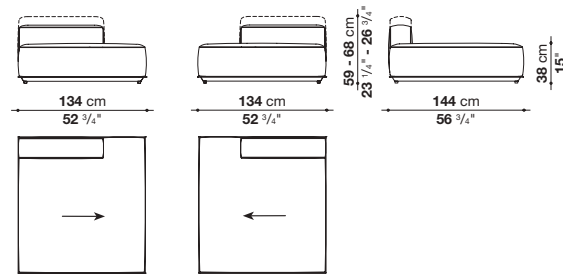

HY200L

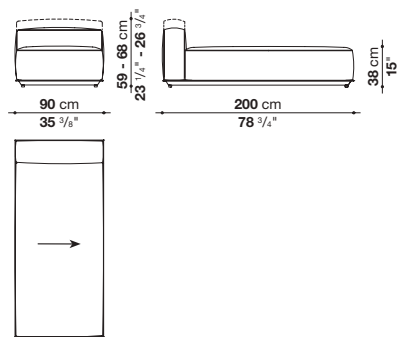

Ottomans
Pouf

HY90P

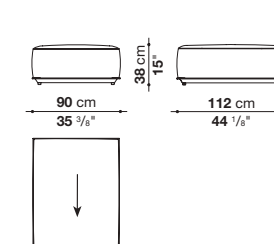

HY178P

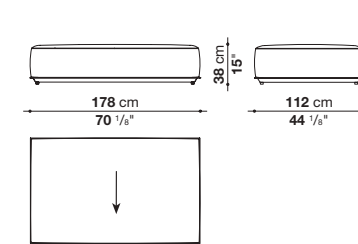

9HY112P

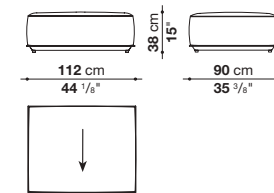

HY134PQ

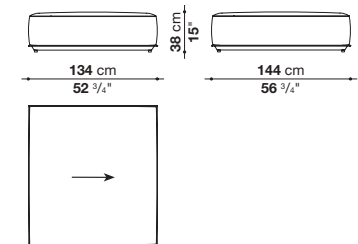

9HY178P

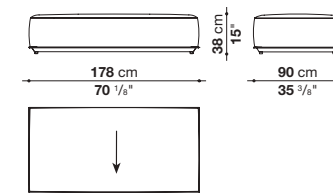

Hybrid

Antonio Citterio • 2020

Inspiration • 62

Frame	die-cast aluminium and extrusions with polyester powder painting
Upholstery	shaped polyurethane, cover in water repellent polyester fibre
Slats	glass fibre
Ferrules	thermoplastic material
Waterproof cover cloth	PES fabric coated on one side in PU
Cover	fabric in limited categories (with profile)

Struttura	pressofusione ed estrusi d'alluminio con verniciatura a polvere poliestere
Imbottitura	poliuretano sagomato, fodera in fibra di poliestere con trattamento idrorepellente
Doghe	fibra di vetro
Puntali	materiale termoplastico
Telo di copertura impermeabile	tessuto PES monospalmato su un lato PU
Rivestimento	tessuto in categorie limitate (con profilo)

Frame Struttura



0427S
sage painted
verniciato salvia

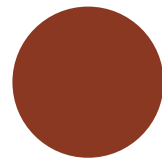

0750A
clay painted
verniciato argilla

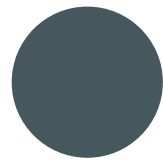

0236B
anthracite painted
verniciato antracite

Seat and back cushion profile Profilo cuscino sedile e schienale

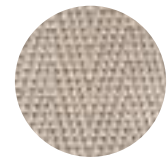

0041E
cream white
bianco panna



0082N
natural
naturale

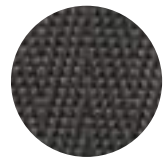

0054G
dark grey
grigio scuro

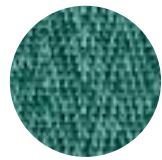

00585A
aquamarine
acquamarina



0075R
red
rosso

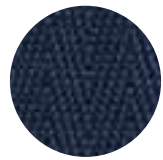

0095B
blue
blu

The colours and materials shown are an indication. Images not in scale.
La tonalità dei colori e dei materiali è indicativa. Immagini non in scala.

Product compositions/Esempi di composizioni Recommended combinations/Abbinamenti suggeriti



2601403
Saturno



2601151
Saturno



0082N
natural profile
profilo naturale



0236B
anthracite painted
verniciato antracite



2601377
Saturno



0082N
natural profile
profilo naturale



0427S
sage painted
verniciato salvia



601151
Saturno



2601258
Saturno



0082N
natural profile
profilo naturale



0236B
anthracite painted
verniciato antracite



2570810
Elisir



2601800
Saturno



0095B
blue profile
profilo blu



0236B
anthracite painted
verniciato antracite



2601800
Saturno



570815
Elisir



0054G
dark grey profile
profilo grigio scuro



0236B
anthracite painted
verniciato antracite



2570410
Elisir



2570420
Elisir



0082N
natural profile
profilo naturale



0236B
anthracite painted
verniciato antracite

The colours and materials shown are an indication. Images not in scale.
La tonalità dei colori e dei materiali è indicativa. Immagini non in scala.

Kaleidos
B&B Italia CR&S 2018
Inspiration • 266

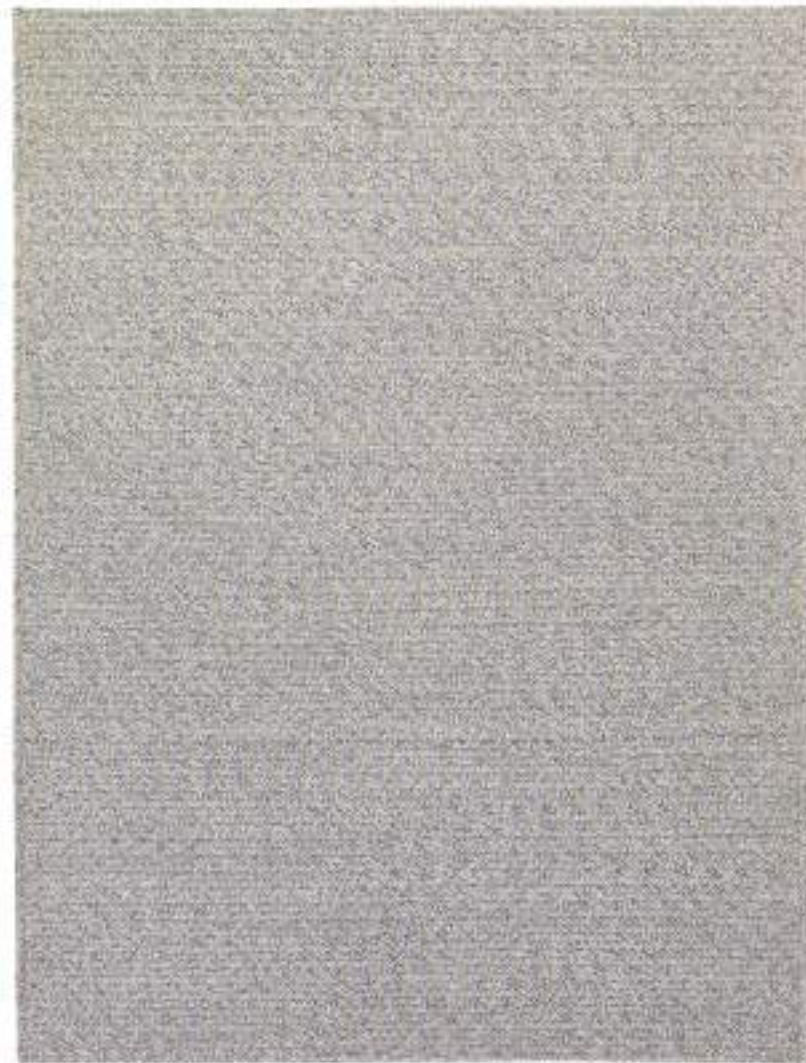

Carpet	braided ropes with dyed Olyna FLYER® fibre	Tappeto	corde intrecciate con fibra tinta Olyna FLYER®
Composition	100% polyolefin	Composizione	100% poliolefine

Carpets
Tappeti

TKA01

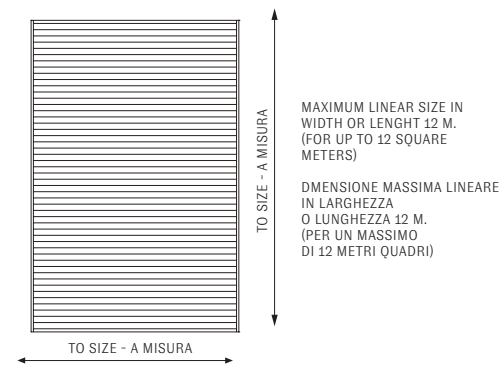

TKA200

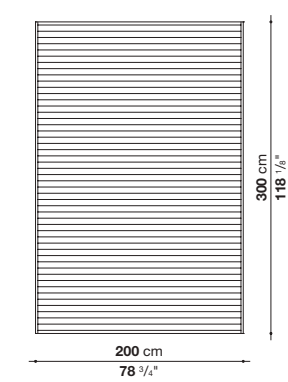

TKA250

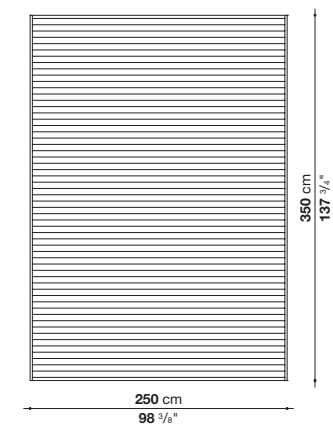

TKA300

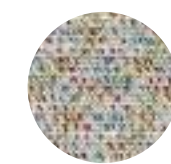
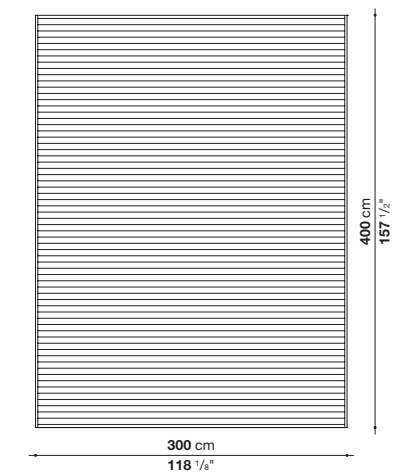

0021M
multicolour polyolefin
multicolore poliolefine

The colour and material shown are an indication. Image not in scale.
La tonalità del colore e del materiale è indicativa. Immagine non in scala.

Karam
B&B Italia CR&S. 2019
Inspiration • 260



Composition	100% polyolefin	Composizione	100% poliolefine
-------------	-----------------	--------------	------------------

Table bowls
Ciotole da tavolo

KA01

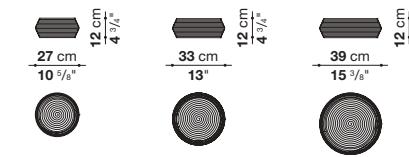

Floor baskets
Ceste da terra

KA02

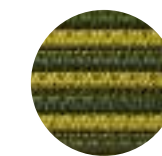
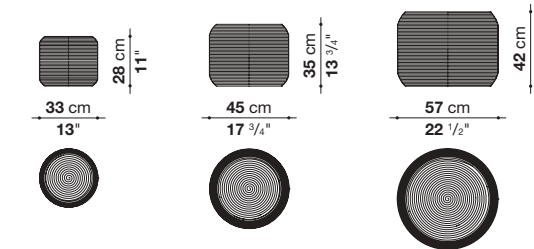

0467V
olive green / pistachio
polyolefin
poliolefine
verde oliva / pistacchio

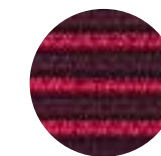

0719B
violet / red
polyolefin
poliolefine
viola / rosso

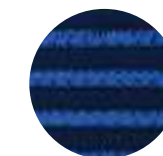

0842B
overseas blue/ blue royal
polyolefin
poliolefine
blu oltremare / blu royal



0288T
stone / anthracite
polyolefin
poliolefine
sasso / antracite

The colours and materials shown are an indication. Images not in scale.
La tonalità dei colori e dei materiali è indicativa. Immagini non in scala.

Kyra
B&B Italia CR&S 2019
Inspiration • 262

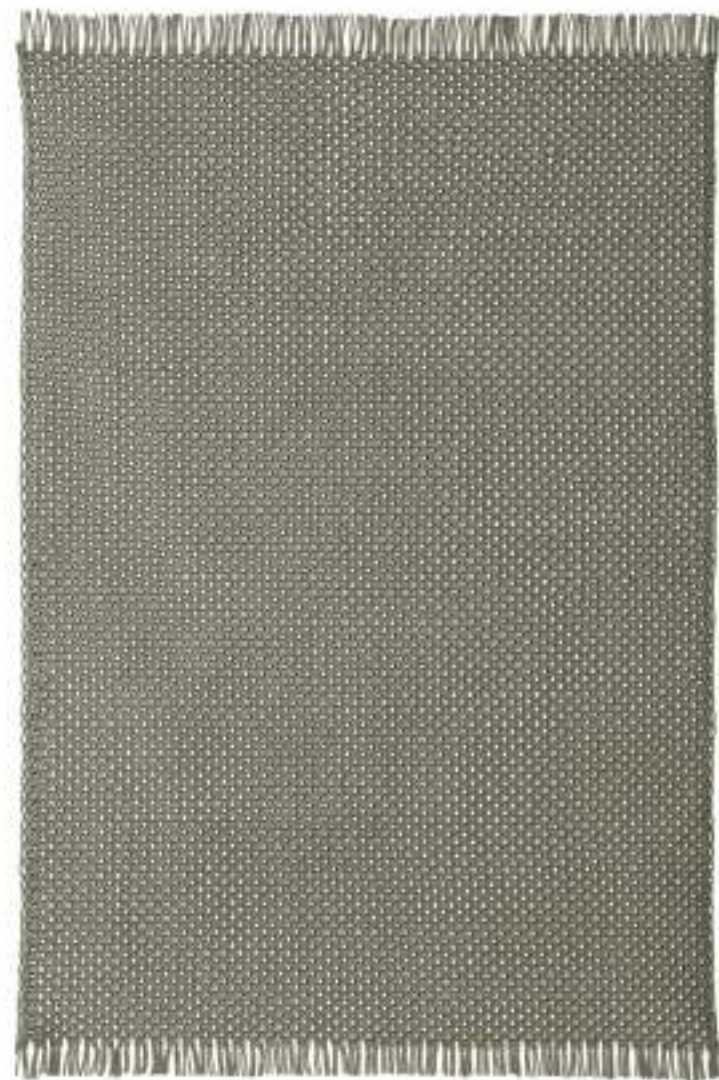

Carpet	braided ropes with dyed Olyna FLYER® fibre
Composition	100% polyolefin

Tappeto	corde intrecciate con fibra tinta Olyna FLYER®
Composizione	100% poliolefine

Carpet
Tappeto

TY200

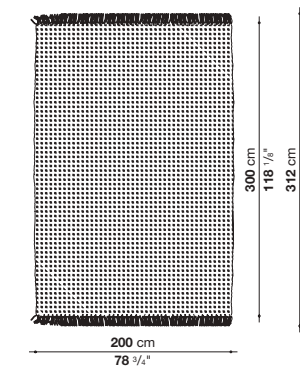

0025T
stone polyolefin
sasso poliolefine



0045V
olive green polyolefin
verde oliva poliolefine

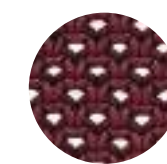

0074B
violet polyolefin
viola poliolefine

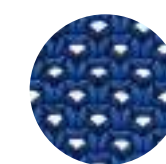

0094R
blue royal polyolefin
blu royal poliolefine



0083B
overseas blue polyolefin
blu oltremare poliolefine

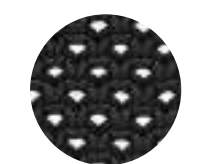

0064A
anthracite polyolefin
antracite poliolefine

The colours and materials shown are an indication. Images not in scale.
La tonalità dei colori e dei materiali è indicativa. Immagini non in scala.

Link Outdoor

Jakob Wagner • 2009

Inspiration • 220



One-of-a-kind, this piece has been moulded in a continuous, joint-free shape: Link Outdoor stands out for its “soft” material and sensual shape. The material makes you want to reach out and touch its smooth surface. An interestingly shaped dining table dominates the room: Danish designer Jakob Wagner places his pure, contemporary mark on this room, typical of northern design. The table is made in a single piece and there are no hooks or joints. Made from a practical technological material: a special type of Cristalplant Outdoor® ensures that it is suitable for outdoor use. It is a resin, in a fluid form that is moulded into the desired shape, a concept in line with B&B Italia’s production philosophy for upholstered furniture. Cristalplant Outdoor® has a velvety smooth surface, an effective soft-touch surface that feels wonderful.

Pezzo unico, plasmato, continuo, privo di giunti: Link Outdoor si distingue per la sua matericità “morbida”, per la sensualità della sua forma e del suo materiale che suscitano il desiderio di sfiorarne la superficie levigata. Un tavolo da pranzo sinuoso, plastico, protagonista dello spazio: lo firma il designer danese Jakob Wagner che ci mette il suo segno purissimo e contemporaneo, tipico del design nordico. Il tavolo è realizzato in un unico stampo e non prevede l'utilizzo di agganci e giunture. Tecnologico e pratico il materiale che lo compone: una speciale miscela in Cristalplant Outdoor® che assicura l'utilizzo da esterni e da interno. La resina, è in forma fluida e viene lavorata con stampi, concetto in linea con la filosofia di produzione degli imbottiti di B&B Italia. Al tatto Cristalplant Outdoor® si caratterizza per la superficie vellutata con effetto soft-touch di notevole impatto sensoriale.

Top and legs	Cristalplant Outdoor® (natural mineral filler of phosphate of aluminium with polyester acrylate resin)	Piano e gambe	Cristalplant Outdoor® (carica minerale naturale di idrato d'alluminio con resina poliestere acrilata)
Waterproof cover cloth	PES fabric coated on one side in PU	Telo di copertura impermeabile	tessuto PES monospalmato su un lato PU

Tables

Tavoli

TLK190N

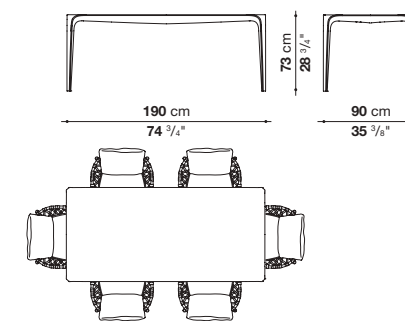

TLK250N

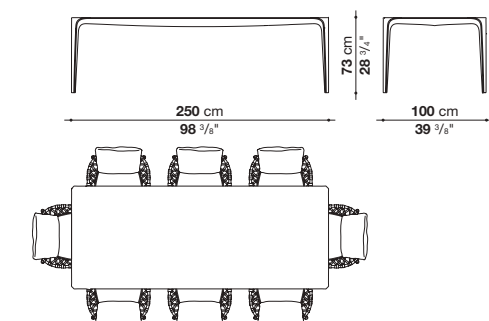

Top and legs

Piano e gambe

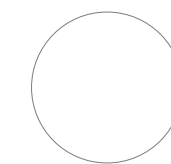

0101G
white Cristalplant Outdoor®
Cristalplant Outdoor® bianco

The colour and material shown are an indication. Image not in scale.
La tonalità del colore e del materiale è indicativa. Immagine non in scala.

Mirto Outdoor

Antonio Citterio • 2013
Inspiration • 120



A classic is born. It expresses Antonio Citterio's stable elegance. Different types of seat: chairs, armchairs and a sunbeds are included in the collection. The folding armchair revisits the classic shape of the director's chair, with exclusive details.

Nasce un classico che esprime l'eleganza stabile e riconoscibile del suo autore. Fanno parte della collezione diverse tipologie di seduta: sedie, poltrone, lettini con schienale reclinabile ed una poltroncina pieghevole che rielabora il lessico della classica tipologia da regista, con dettagli accurati.

Mirto Outdoor
Antonio Citterio • 2013
Inspiration • 120



Details like the light aluminium structure, the mesh in Batyline® Canatex, in which hemp fibre confers a more rustic natural look compared to plastics that are usually used in this sector. The edges are cut, sewn and glued masterfully around the profiles to create minimal décor.

Dettagli come la struttura leggera in alluminio, la rete in Batyline® Canatex, la cui fibra di canapa conferisce una mano più rustica e naturale rispetto alle plastiche in uso nel settore. I bordi tagliati, cuciti e incollati con sapienza seguono i profili e dettano il decoro minimal.

Mirto Outdoor
Antonio Citterio • 2013
Inspiration • 120



All sizes of tables, low tables, small tables and consoles have the same frame and top in painted aluminium, in brushed natural Iroko slats, in Calacatta white porcelain stoneware or in enamelled lava stone with anthracite, clay, sage decoration. The quality and attention to detail make Mirto a collection that is made to last.

Tavoli, tavoli bassi, tavolini e console hanno la stessa struttura e top in lamiera verniciata, con doghe di Iroko naturale spazzolato, in gres porcellanato bianco Calacatta o in pietra lavica smaltata con decoro antracite, argilla, o salvia. L'aspetto qualitativo e la cura dei dettagli fanno di Mirto una collezione fatta per durare nel tempo.

Mirto Outdoor

Antonio Citterio • 2013

Inspiration • 120



In 2019 the Mirto collection is also being expanded to include new designs and finishes starting with the folding director's chair now in ecru canvas with natural thick leather armrests and a die-cast aluminium frame in the new colours, clay and sage. There is also a series of very innovative dining, tables, low tables, small tables and console in several sizes that reproduce the collection's minimalist design elements with a fresh take on colours and decorations.

La collezione Mirto si amplia nel 2019 con nuove proposte e finiture, a partire dalla sedia regista pieghevole ora presentata con un rivestimento in tela ecru con braccioli in cuoio naturale e struttura in pressofusione di alluminio nei nuovi colori argilla e salvia. La grande novità è rappresentata dalla serie di tavoli da pranzo, tavoli bassi, tavolini e console in varie dimensioni che riprendono il disegno essenziale di quelli già parte della collezione, ma introducono i temi del colore e del decoro.



The die-cast aluminium frame comes in three new varnishes - clay, sage and anthracite - and the table tops are made of black lava stone laid out in designs based on traditional Sicilian lace in the three different frame shades.

A really innovative technique has been used to manufacture the decorative tiles using a special material obtained by crushing recycled electronic equipment screens which is then applied to the surface of the tiles using an exclusive production process.

Le strutture in pressofusione d'alluminio sono verniciate nei colori argilla, salvia e antracite, mentre i piani sono realizzati con piastrelle di pietra lavica smaltata con decori che riproducono il disegno di un pizzo siciliano tradizionale da abbinare alle tre tonalità delle strutture. La tecnica di stampa delle piastrelle è altamente innovativa e utilizza per il decoro uno speciale materiale ottenuto dalla frantumazione del vetro di monitor e strumenti elettronici dismessi, poi applicato alla superficie delle piastrelle tramite un esclusivo processo di lavorazione.

Mirto Outdoor
Antonio Citterio • 2013
Inspiration • 120



Mirto Outdoor

Antonio Citterio • 2013

Inspiration • 120

Sunbeds with adjustable back
 Lettini con schienale regolabile

MI74CL

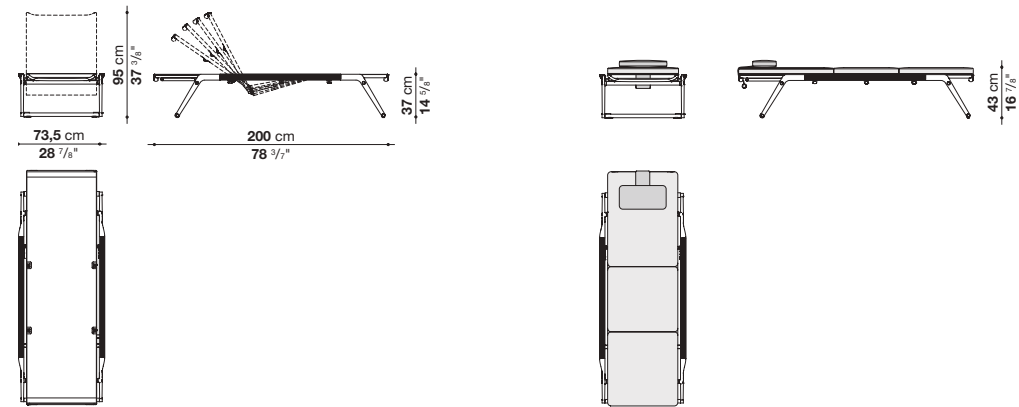

MI74CL_P

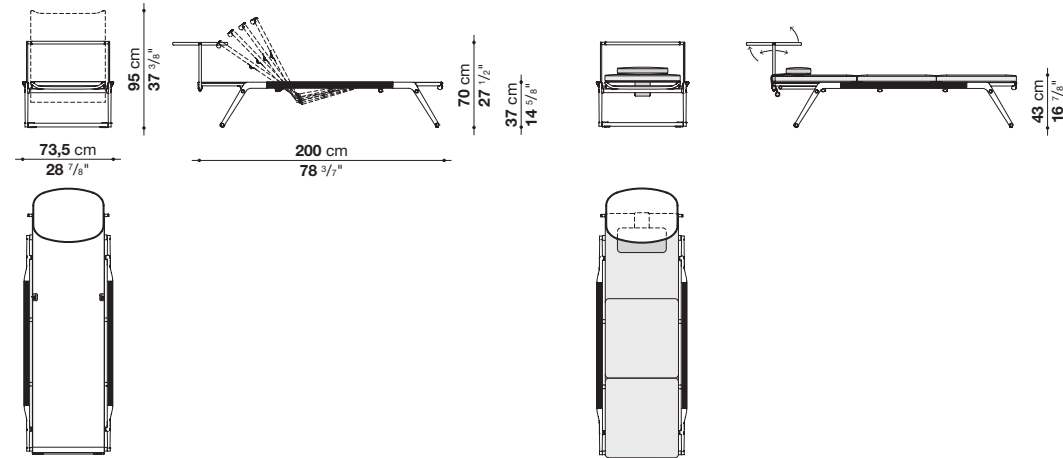

Sunbeds with adjustable back
 Lettini con schienale regolabile

MI200CL

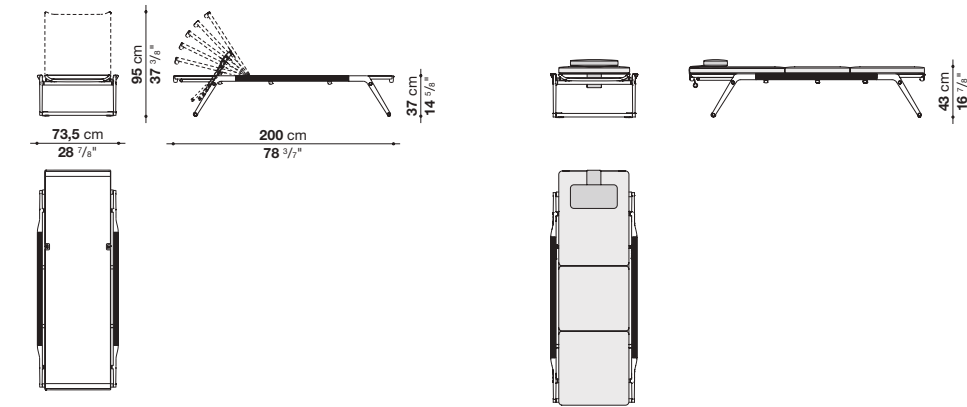

MI200CL_P

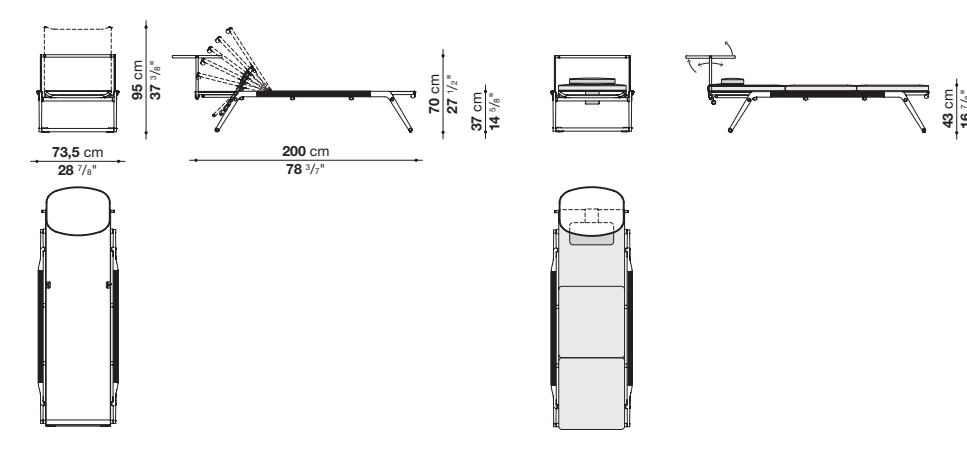

Mirto Outdoor

Antonio Citterio • 2013

Inspiration • 120

Folding small armchair
Poltroncina pieghevole

MI59N - MI59SR

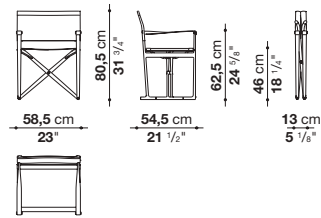

Small armchair
Poltroncina

MI65P

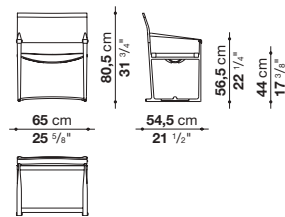

Chair
Sedia

MI58S

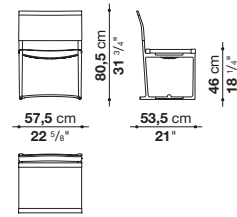

Frame	die-cast aluminium and extrusions with polyurethane painting
Seat and back	Stige mesh in Batyline® Canatex
Seat and back (MI59N)	fabric in limited categories
Edges and armrests	Batyline® Keops
Armrests (MI59N)	waterproof thick leather
Wheels (M200CL-MI74CL)	acetal resin
Hinges (M200CL-MI74CL)	micro die-cast stainless steel
Handrail (M200CL-MI74CL)	vulcanised thermoplastic material
Upholstery (small mattress and headrest)	shaped polyurethane polyester fibre cover
Ferrules	thermoplastic elastomer
Waterproof cover cloth (M200CL-MI74CL)	PES fabric coated on one side in PU

Struttura	pressofusione ed estrusi d'alluminio con verniciatura poliuretanicca
Sedile e schienale	rete Stige in Batyline® Canatex
Sedile e schienale (MI59N)	tessuto in categorie limitate
Bordi e braccioli	Batyline® Keops
Braccioli (MI59N)	cuoio impermeabile
Ruote (M200CL-MI74CL)	resina acetaleca
Cerniere (M200CL-MI74CL)	microfusione d'acciaio inossidabile
Corrimano (M200CL-MI74CL)	materiale termoplastico vulcanizzato
Imbottitura (materassino e poggiatesta)	poliuretano sagomato, fodera in fibra di poliestere
Puntali	elastomero termoplastico
Telo di copertura impermeabile (M200CL-MI74CL)	tessuto PES monospalmato su un lato PU

Frame
Struttura

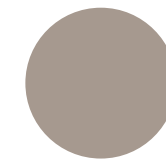

0380T
tortora painted
verniciato tortora

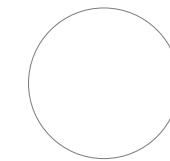

0186V
white painted
verniciato bianco

Edge and armrests
Bordi e braccioli

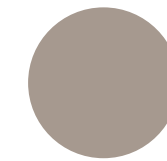

0280T
tortora colour
color tortora

Seat and back
Sedile e schienale

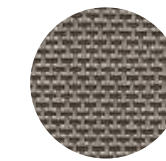

2445280
Stige tortora
Stige tortora

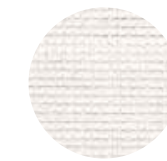

2445102
natural white Stige
Stige bianco naturale

Frame (MI59N)
Struttura

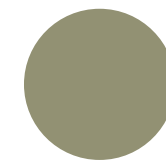

0427S
sage painted
verniciato salvia

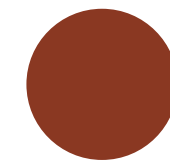

0750A
clay painted
verniciato argilla

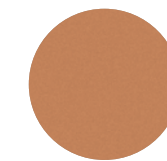

0136N
natural color
colore naturale

Armrests (MI59N)
Braccioli

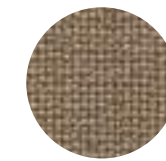

2572102
natural Laguna
Laguna naturale

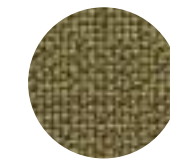

2822401
moss green Lamar
Lamar verde muschio

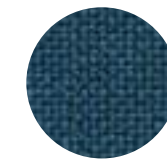

2822890
Sea blue Lamar
Lamar blu mare

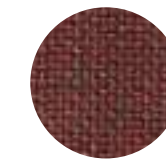

2822760
Lamar argilla
clay Lamar

The colours and materials shown are an indication. Images not in scale.
La tonalità dei colori e dei materiali è indicativa. Immagini non in scala.

Mirto Outdoor

Antonio Citterio • 2013

Inspiration • 120

Tables_painted or porcelain stoneware top
Tavoli_piano verniciato o in gres porcellanato

MI90T - MI90TG

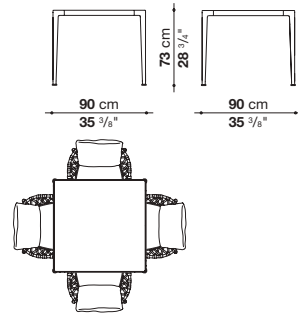

MI150TQ - MI150TQG

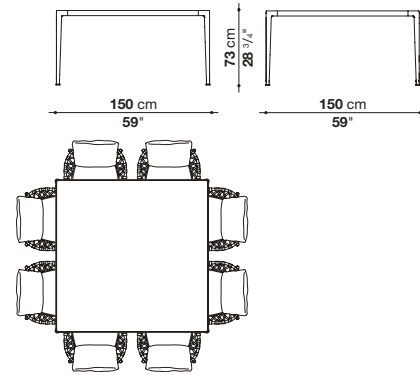

MI160T - MI160TG

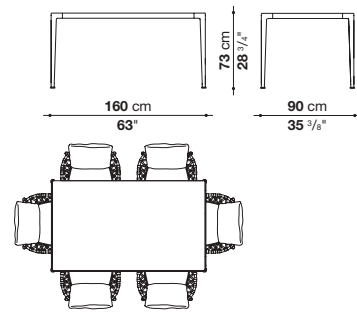

Low tables_painted or porcelain stoneware top
Tavoli bassi_piano verniciato o in gres porcellanato

MI120Q_4 - MI120Q_4G

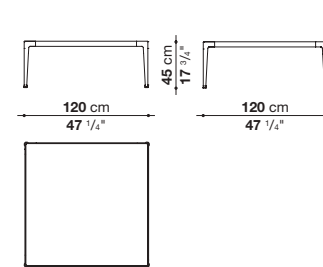

MI120_4 - MI120_4G

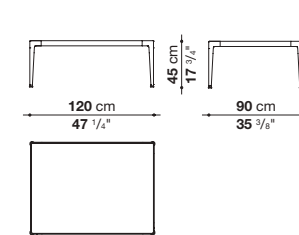

MI220T - MI220TG

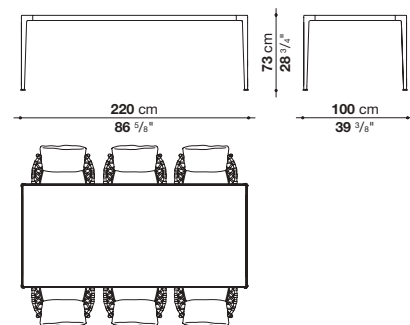

MI250T - MI250TG

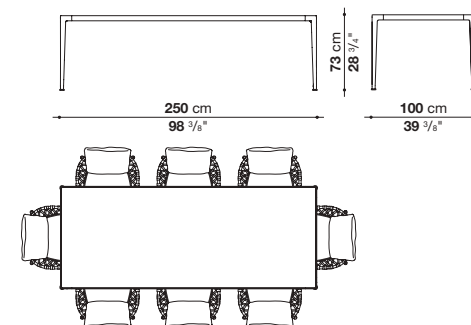

MI180_4 - MI180_4G

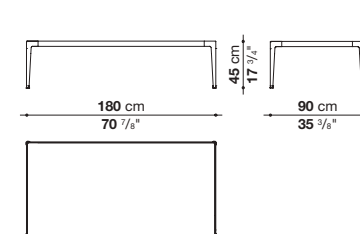

MI200_4 - MI200_4G

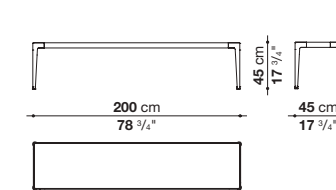

Consoles_painted or porcelain stoneware top
Console_piano verniciato o in gres porcellanato

MI150_6 - MI150_6G

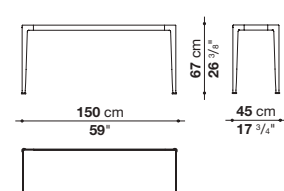

MI200_6 - MI200_6G

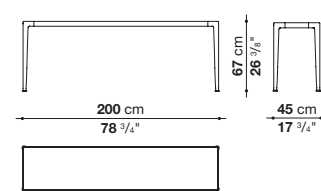

MI250_6 - MI250_6G

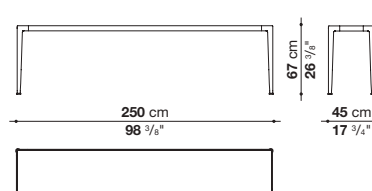

Small tables_painted or porcelain stoneware top
Tavolini_piano verniciato o in gres porcellanato

MI90Q_4 - MI90Q_4G

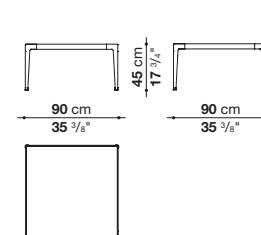

MI54T

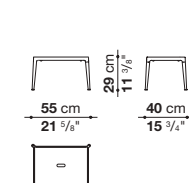

MI55_5

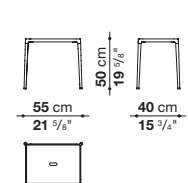

Mirto Outdoor

Antonio Citterio • 2013

Inspiration • 120

Tables_Iroko wood slats top
Tavoli_piano in doghe di legno Iroko

MI90TL

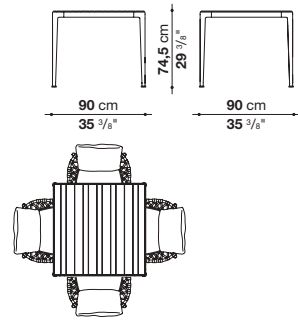

MI150TQL

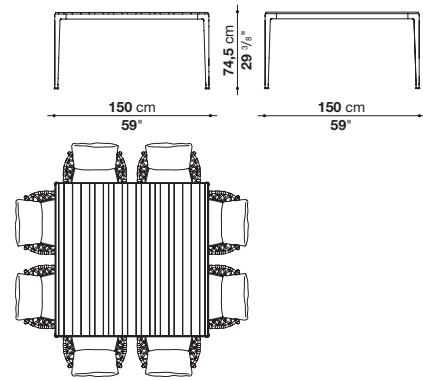

MI160TL

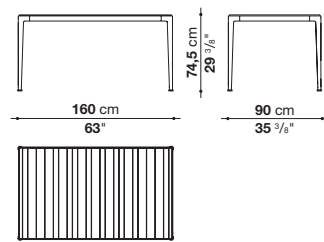

Low tables_Iroko wood slats top
Tavoli bassi_piano in doghe di legno Iroko

MI120Q_4L

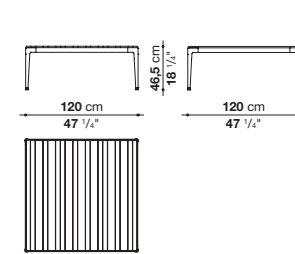

MI120_4L

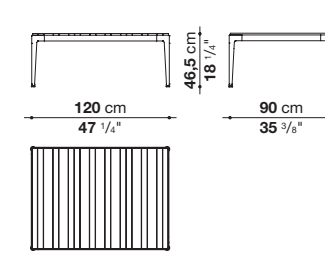

MI220TL

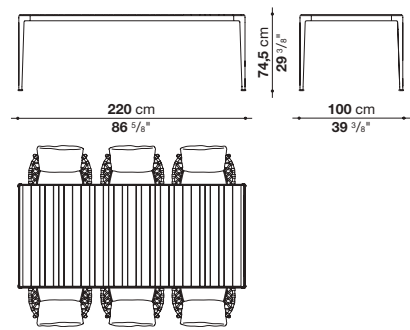

MI250TL

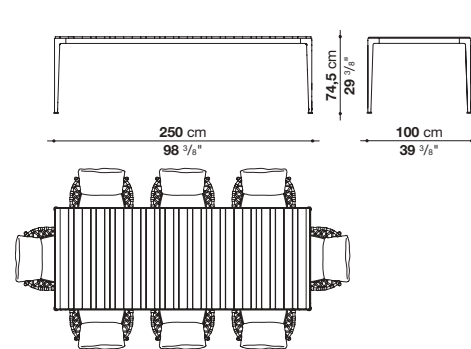

MI180_4L

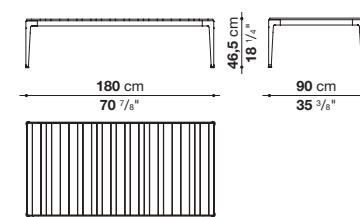

MI200_4L

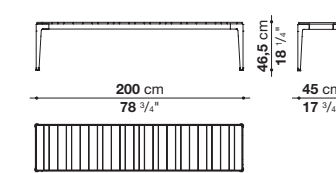

Consoles_Iroko wood slats top
Console_piano in doghe di legno Iroko

MI150_6L

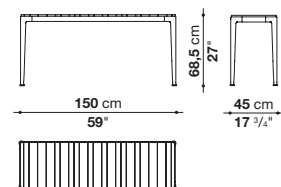

MI200_6L

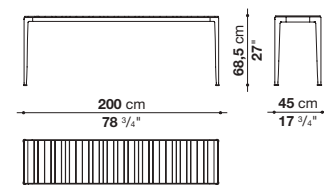

MI250_6L

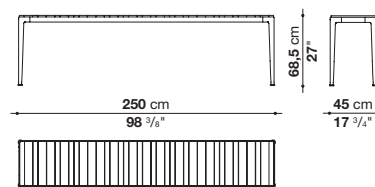

Small table_Iroko wood slats top
Tavolino_piano in doghe di legno Iroko

MI90Q_4L

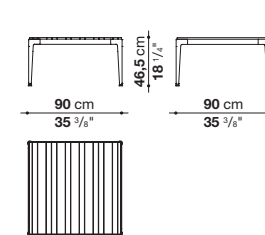

Mirto Outdoor

Antonio Citterio • 2013

Inspiration • 120

Tables_ enamelled lava stone with decoration top
Tavoli_piano in pietra lavica smaltata con decoro

TM0162Q

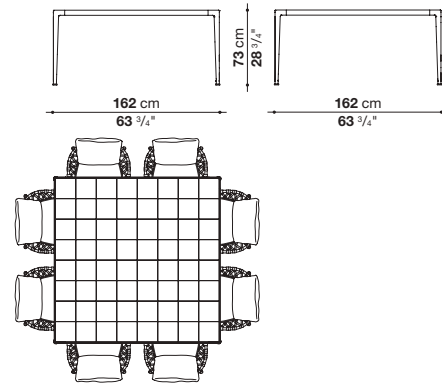

TM0222

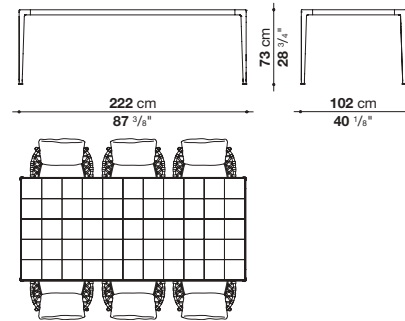

TM0162_6

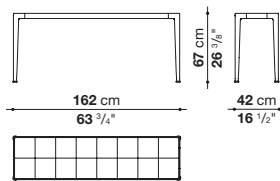

Low table_ enamelled lava stone with decoration top
Tavolo basso_piano in pietra lavica smaltata con decoro

TM0162_4

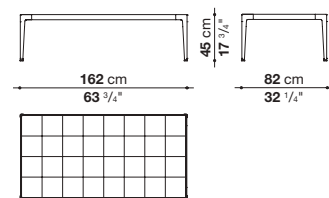

Small table_ enamelled lava stone with decoration top
Tavolino_piano in pietra lavica smaltata con decoro

TM082Q_4

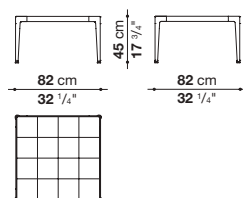

Frame	die-cast aluminium and extrusions with polyurethane painting
Top	aluminium sheet with polyurethane painting, porcelain stoneware, wooden slats or enamelled lava stone
Top (MI54T - MI55_5)	die-cast aluminium with polyurethane painting
Ferrules	thermoplastic elastomer
Waterproof cover cloth	PES fabric coated on one side in PU

Struttura	pressofusione ed estrusi d'alluminio con verniciatura poliuretana
Piano	lamiera d'alluminio con verniciatura poliuretana, gres porcellanato, doghe di legno o pietra lavica smaltata su piano in alluminio
Piano (MI54T - MI55_5)	pressofusione d'alluminio con verniciatura poliuretana
Puntali	elastomero termoplastico
Telo di copertura impermeabile	tessuto PES monospalmato su un lato PU

Tables, low table, small table and console frame
Struttura tavoli, tavolo basso, tavolino e console

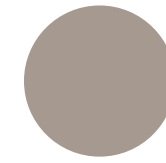

0380T
tortora painted
verniciato tortora

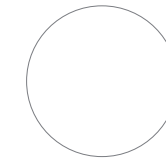

0186V
white painted
verniciato bianco

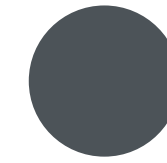

0236B
anthracite painted
verniciato antracite

Tables, low table, small table and console top
Piano tavoli, tavolo basso, tavolino e console

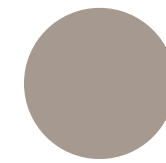

0380T
tortora painted
verniciato tortora

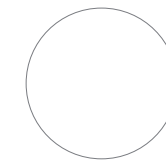

0186V
white painted
verniciato bianco

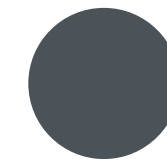

0236B
anthracite painted
verniciato antracite



0405I
brushed natural Iroko wood
Iroko naturale spazzolato



0301B
Calacatta white porcelain stoneware
gres porcellanato bianco Calacatta

Top and frame (MI54T - MI55_5)
Struttura e piano

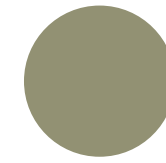

0427S
sage painted
verniciato salvia

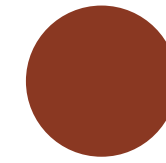

0750A
clay painted
verniciato argilla

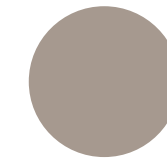

0380T
tortora painted
verniciato tortora

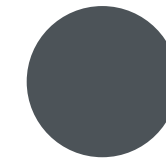

0236B
anthracite painted
verniciato antracite

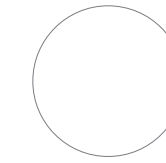

0186V
white painted
verniciato bianco

Frame and top matching (TM0162Q - TM0222 - TM0162_6 - TM082Q_4 - TM0162_4)
Abbinamento struttura e piano

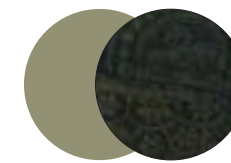

0427S / 0406V

sage painted / enamelled lava stone with green decoration
verniciato salvia / pietra lavica smaltata con decoro salvia

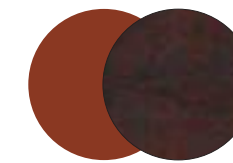

0750A / 0703A

clay painted / enamelled lava stone with clay decoration
verniciato argilla / pietra lavica smaltata con decoro argilla



0236B / 0164A

anthracite painted / enamelled lava stone with anthracite decoration
verniciato antracite / pietra lavica smaltata con decoro antracite

The colours and materials shown are an indication. Images not in scale.
La tonalità dei colori e dei materiali è indicativa. Immagini non in scala.

Oh, it rains!

Philippe Starck · 2020

Inspiration • 74



The collaboration between B&B Italia and Philippe Starck leads to the birth of a sofa and an armchair, both with impressive dimensions and highly scenographic presence, that surprisingly combine an unusual shape and an unexpected function, with a name that really attracts attention. The designer started his research for this project by going back to the origins of outdoor furniture, that of nomads and soldiers: desert tents and field equipment, colonial colors and very light materials, essential shapes with function connected with rapid action. Colours and materials go hand in hand with the initial concept and the collection introduces colonial shades waterproof fabrics. The collection is enhanced by optional cushions that guarantee extra comfort and a dynamic look to this large object, suitable for private settings and also for outdoor areas in hotels and lounge. From a technical standpoint, the backrest is made with a double layer of water-repellent fabric, which makes it 100% waterproof. It is also possible to choose the version with a side table integrated into the structure, available in Mediterranean stone.

Nata dalla collaborazione tra B&B Italia e Philippe Starck, la collezione Oh, it rains! propone un divano e una poltrona studiati per essere utilizzati all'aperto con un design elegante, frutto di una funzionalità iconoclasta, che si adatta alla perfezione a qualsiasi ambiente pubblico o privato che sia.

Il designer si è ispirato alle origini del concetto di outdoor e di arredamento per esterni: tende del deserto e attrezzature da campo tipiche dei popoli nomadi e dei soldati, colori coloniali e materiali molto leggeri, forme essenziali dalle funzionalità intuitive e di facile implementazione. I colori e i materiali utilizzati sfoggiano una tavolozza di tonalità che vanno dal beige al marrone caldo. I tessuti sono idrorepellenti e rendono il prodotto completamente impermeabile.

La collezione è arricchita da numerosi cuscini opzionali che garantiscono ancora più comfort e dinamicità a questo prodotto adatto sia ad ambienti privati che ad aree outdoor di hotel e lounge. Infine, nella struttura della seduta, è possibile integrare un tavolino in pietra mediterranea.

Sofa

Divano

OH280

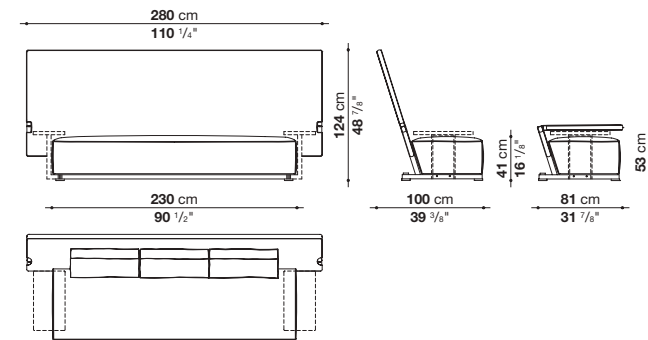

Armchair

Poltrona

OH140PS - OH140PD

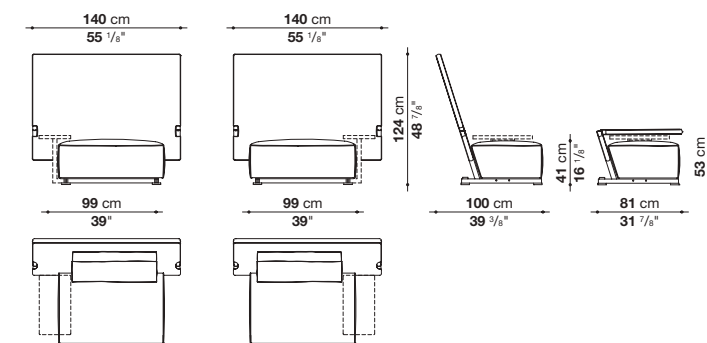

Small table

Tavolino

TOH1

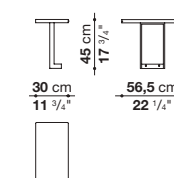

Oh, it rains!

Philippe Starck · 2020

Inspiration • 74

The large backrest of the product it is not just decorative but it acts like a wall or a partition to create an intimate and private setting. When necessary, it folds down on top of the seat so cushions and seat are covered and protected.

L'ampio schienale non è solo decorativo ma crea in maniera del tutto naturale uno spazio intimo e privato che grazie alla impeccabile ergonomia si reclinata facilmente sulla seduta, in caso di pioggia o maltempo, in modo che cuscini e seduta siano coperti e protetti.



Frame	aluminium
Upholstery	shaped polyurethane, cover in water repellent polyester fibre
Small table (TOH1)	Mediterranean stone
Ferrules	plastic material
Waterproof cover cloth	PES fabric coated on one side in PU
Cover	fabric in limited categories

Struttura	alluminio
Imbottitura	poliuretano sagomato, fodera in fibra di poliestere con trattamento idrorepellente
Piano tavolino (TOH1)	pietra Mediterranea
Puntali	materiale plastico
Telo di copertura impermeabile	tessuto PES monospalmato su un lato PU
Rivestimento	tessuto in categorie limitate

Frame
Struttura



0722T
titanium
titanio

Feet
Piedini

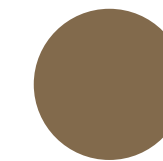

0521B
bronze
bronzo

Hinge
Cerniera

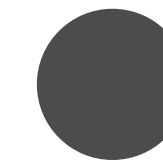

0031A
warm grey anodized
anodizzato warm grey

Small table top (TOH1)
Piano tavolino

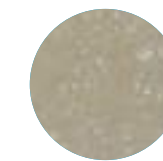

0463P
Mediterranean stone
pietra Mediterranea

Overscale Flames Outdoor

Jean-Marie Massaud • 2008

Inspiration • 252



The large oil candles designed by Jean-Marie Massaud are in high density polyurethane resin (Baydur®), with a metallic frame painted matt white.

Le grandi candele a olio disegnate da Jean-Marie Massaud sono in resina poliuretanicca ad alta densità (Baydur®), con struttura metallica verniciata bianca opaca.

Frame	metal profiles	Struttura	profili metallici
Shell	high density polyurethane resin (Baydur®)	Corpo	resina poliuretanicca ad alta densità (Baydur®)
Nozzles	anodized aluminium	Ugelli	alluminio anodizzato

Candles

Candele

AB20043B

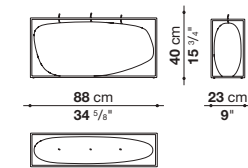

AB20044B

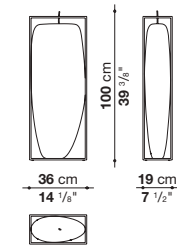

Frame and shell

Struttura e corpo

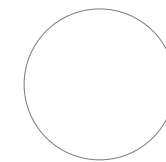

white
bianco

The colour and material shown are an indication. Image not in scale.
La tonalità del colore e del materiale è indicativa. Immagine non in scala.

Pablo Outdoor
 Vincent Van Duysen • 2022
 Inspiration • 4



The Pablo collection by Vincent Van Duysen, with its decisive design, rigorous strict lines and innovative proportions, breathing life to a series that includes a sofa, an armchair in two depths, a footrest and two coffee tables.

La collezione Pablo di Vincent Van Duysen, con il suo design deciso, le linee rigorose e le sue proporzioni innovative, dà vita a una serie che comprende un divano, una poltrona in due profondità, un poggiatesta e due tavolini.

The soul of the original project lies in the wood frame, which for Pablo Outdoor is made of teak, the ideal material for outdoors. The geometry of the supporting frame presents a sophisticated balance of straight and curved lines, but this is not just an aesthetic choice. In fact, the frame, with its uninterrupted surface, was designed to ease maintenance of the wood, which is easy to treat as necessary. The continuity of the form and quality of the wood make Pablo Outdoor particularly pleasant to the touch.

L'anima del progetto originario si ritrova nella struttura in legno, che per Pablo Outdoor diventa teak, materiale ideale per l'outdoor. La geometria della struttura portante presenta sofisticati equilibri di linee rette e curve, ma non si tratta soltanto di una scelta estetica. Infatti, la struttura dalla superficie ininterrotta è stata ideata in modo da favorire la manutenzione del legno, agevole da trattare all'occorrenza. La continuità della forma e la qualità del legno rendono Pablo Outdoor particolarmente piacevole al tatto.

Pablo Outdoor

Vincent Van Duysen • 2022

Inspiration • 4



For the sofa, comfort and softness are found in the deep seat and back enhanced with cushions that can be arranged freely. The low seat is composed of a single generously upholstered cushion, nearly a mattress that creates an ample area perfect for isolating yourself or sharing moments of conviviality.

Nel divano, comodità e morbidezza derivano dalla seduta profonda e dallo schienale arricchito da cuscini a disposizione libera. La seduta ribassata è formata da un unico cuscino dalla generosa imbottitura, quasi un materasso che crea una dimensione ampia, perfetta per isolarsi o per condividere occasioni conviviali.



The rear fabric panels are anchored to rods that can be removed easily. This is also an aesthetic choice that meets a technical solution aimed at simplifying care for the wood and maintenance of the textile parts. These design expedients allow customers choosing the Pablo Outdoor collection to let it age naturally or have it returned its original condition.

I pannelli posteriori in tessuto si ancorano a bacchette facilmente rimovibili: anche in questo caso una scelta estetica che incontra una soluzione tecnica mirata a semplificare la cura del legno e la manutenzione delle parti tessili. Si tratta di accorgimenti progettuali che consentono a chi sceglie la collezione Pablo Outdoor di lasciarla invecchiare naturalmente, oppure di farla tornare rapidamente alla condizione d'origine.

Pablo Outdoor
Vincent Van Duysen • 2022
Inspiration • 4



The sofa interacts also with the armchair available in two depths, one more suited to conversation, the other for relaxing as if on a chaise longue.

Il divano dialoga inoltre con la poltrona in due varianti di profondità, una più adatta alla conversazione, l'altra a un relax da chaise longue.

The footrest has a similar teak frame and an upholstered seat covered in fabric. Solid and compact, this accessory is also suitable for use as a service small table.

Il poggiatesta presenta un'analogia struttura in teak e una seduta imbottita rivestita in tessuto. Solido e compatto, questo accessorio diventa adatto anche per l'utilizzo come tavolino di servizio.

Pablo Outdoor

Vincent Van Duysen • 2022

Inspiration • 4



With Pablo Outdoor collection, planning complete and cosy relaxing areas is easy thanks to an additional wooden small element that with the optional cushion can transform itself from a coffee table into a comfy ottoman.

Con la collezione Pablo Outdoor, progettare zone relax complete e accoglienti è facile grazie ad un piccolo elemento aggiuntivo in legno che con il cuscino opzionale può trasformarsi da tavolino in un comodo pouf.



The decisive yet soft lines of Pablo Outdoor seats are perfectly balanced in the small cement outdoor tables. Linear, solid, and highly geometric shapes represent the heart of these architectural objects with a certain effect. To provide multiple solutions, these small tables come in two sizes and two colours. The antique white and greige colours give shape to a large, low model that works perfectly as an island defining a conversation area, and a higher, narrower model with a square base, is ideal as a service element next to the sofa or armchair.

Le linee decise e tuttavia morbide delle sedute Pablo Outdoor trovano il perfetto contraltare nei tavolini da esterni in cemento. Forme lineari, solide, ad alto tasso di geometria, rappresentano il cuore di questi oggetti architettonici dal sicuro impatto. Per fornire molteplici soluzioni, questi tavolini nascono in due misure e due colori. Le tinte bianco antico e greige danno forma a un modello ampio e basso, perfetto come isola che definisce un'area conversazione, e a un modello più alto e slanciato, a base quadrata, ideale come elemento di servizio accanto al divano o alla poltrona.

Pablo Outdoor

Vincent Van Duysen • 2022

Inspiration • 4



The rear panel of Pablo Outdoor wooden structures is available in natural, clay, sea blue and moss green coloured cloth. This fabric rear panel is anchored to rods that can be removed in order to ease washing and maintenance of the product.

Il pannello posteriore delle strutture in legno Pablo Outdoor è disponibile in tela nei colori naturale, argilla, blu mare e verde muschio. Questo pannello posteriore in tessuto è ancorato ad aste che possono essere rimosse per facilitare il lavaggio e la manutenzione del prodotto.



This is also an aesthetic choice that meets a technical solution aimed at simplifying care for the wood and maintenance of the textile parts. These design expedients allow customers choosing the Pablo Outdoor collection to let it age naturally or have it returned its original condition.

Questa è anche una scelta estetica che incontra una soluzione tecnica volta a semplificare la cura del legno e la manutenzione delle parti tessili. Questi accorgimenti progettuali consentono ai clienti che scelgono la collezione Pablo Outdoor di farla invecchiare naturalmente o di riportarla alle condizioni originali.

Pablo Outdoor

Vincent Van Duysen • 2022

Inspiration • 4

Sustainability



The padding of Pablo Outdoor are also displaying another eco-friendly material as the 100% recycled polyester fibres from PET, which convey richness and generous comfort to the cushions.

Le imbottiture di Pablo Outdoor sfoggiano anche un altro materiale ecologico come le fibre di poliestere riciclate al 100% da PET, che donano ricchezza e generoso comfort ai cuscini.

Natural teakwood structures with no metal joints and plastic seat slats underline the sustainability of this collection. Exposure to sunlight and rain will finely age the genuine wood used and the provided B&B Italia maintenance kit helps in maintaining its original sheen.

Strutture in legno di teak naturale senza giunzioni metalliche e doghe di seduta in plastica sottolineano la sostenibilità di questa collezione. L'esposizione alla luce solare e alla pioggia invecchierà il vero legno utilizzato e il kit di manutenzione B&B Italia in dotazione aiuta a mantenere la sua lucentezza originale.

Pablo Outdoor

Vincent Van Duysen • 2022

Inspiration • 4

Sofa
Divano

PBL210

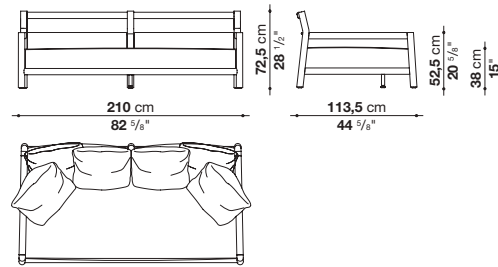

Ottoman*
Pouf*

PBL75P

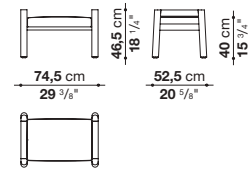

Armchairs
Poltrone

PBL82L

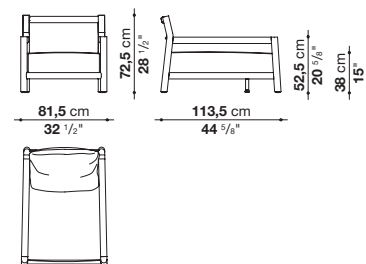

PBL80

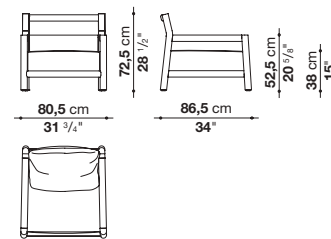

Small tables
Tavolini

TPB130

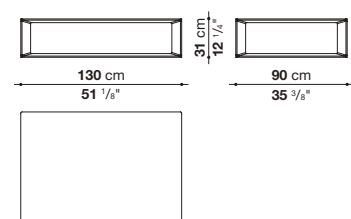

TPB55

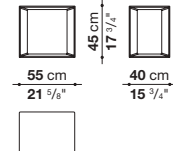

*Not ordering the seat cushion, the ottoman can be used as small table.
*Non ordinando il cuscino sedile, il pouf può essere utilizzato come tavolino.

Frame	solid wood
Upholstery	shaped polyurethane of different density, cover in water repellent polyester fibre
Back support	stainless steel tubular covered in fabric
Seat slats	polypropylene reinforced with glass fibre
Top and frame (TPB55 - TPB130)	cement (Ultra Light Performance Concrete)
Ferrules	thermoplastic material
Waterproof cover cloth	PES fabric coated on one side in PU
Cover	fabric in limited categories

Struttura	legno massello
Imbottitura	poliuretano sagomato a densità differenziata, fodera in fibra di poliestere con trattamento idrorepellente
Supporto schienale	tubolari in acciaio inox rivestiti in tessuto
Doghe seduta	polipropilene rinforzato con fibra di vetro
Piano e struttura (TPB55 - TPB130)	cemento (Ultra Light Performance Concrete)
Puntali	materiale termoplastico
Telo di copertura impermeabile	tessuto PES monospalmato su un lato PU
Rivestimento	tessuto in categorie limitate

Frame
Struttura



0456T
natural teakwood
teak naturale

Top and frame (TPB130 - TPB55)
Piano e struttura



0270B
antique white cement
cemento bianco antico



0240G
greige cement
cemento greige

Back support
Supporto schienale

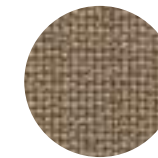

2572102
Laguna_natural
Laguna_naturale

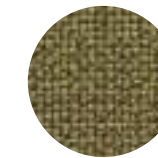

2822401
Lamar_moss green
Lamar_verde muschio

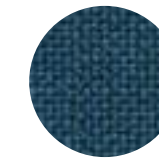

2822890
Lamar_Sea blue
Lamar_blu mare

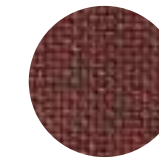

2822760
Lamar_argilla
Lamar_clay

The colours and materials shown are an indication. Images not in scale.
La tonalità dei colori e dei materiali è indicativa. Immagini non in scala.

Papilio Shell Outdoor

Naoto Fukasawa • 2016

Inspiration • 228



Papilio Shell Outdoor is linked through its name to the previous family of very successful chairs and armchairs, but has an independent history. Originating from a shell with a design that enhance comfort, it expresses considerable versatility that makes it perfect in different situations.

Papilio Shell Outdoor cita con il suo nome una precedente famiglia di sedute di grande successo, ma ha una storia indipendente. Originata da una scocca, il cui disegno sottolinea l'accoglienza e la comodità, esprime una notevole versatilità che la rende utilizzabile in situazioni molto diverse tra loro.

Shell	polypropylene
Support frame	stainless steel profiles
Ferrules	thermoplastic material

Scocca	polipropilene
Struttura di sostegno	profilati d'acciaio inossidabile
Puntali	materiale termoplastico

Chair

Sedia

OSH1

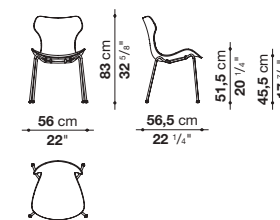

Support frame

Struttura di sostegno

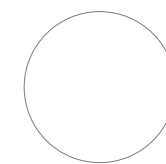

09010
white painted
verniciato bianco

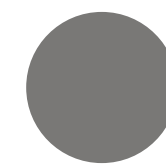

0792T
greige painted
verniciato greige

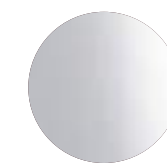

0772C
stainless steel
acciaio inox

Shell

Scocca

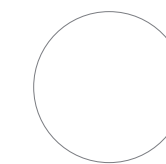

0116B
white polypropylene
polipropilene bianco

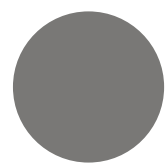

0235G
greige polypropylene
polipropilene greige

The colours and materials shown are an indication. Images not in scale.
La tonalità dei colori e dei materiali è indicativa. Immagini non in scala.

Piet
B&B Italia CR&S 2021
Inspiration • 264



Composition	100% polypropylene	Composizione	100% polipropilene
-------------	--------------------	--------------	--------------------

Carpets
Tappeti

TPI200

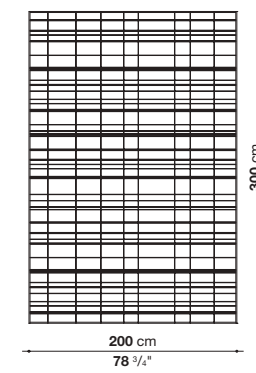

TPI250

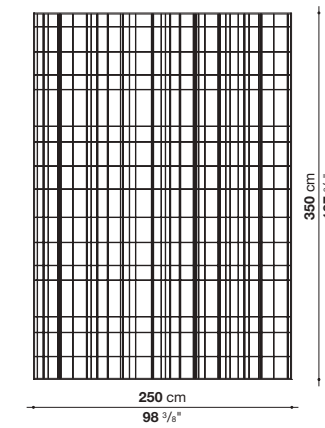

TPI300

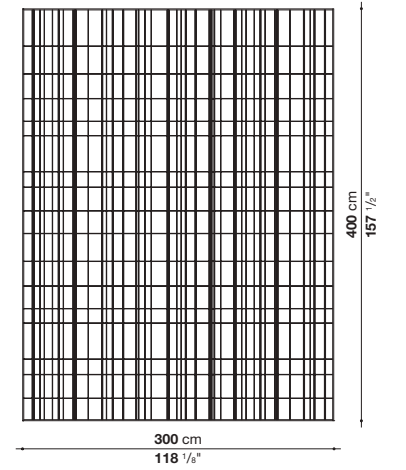

TPI300R

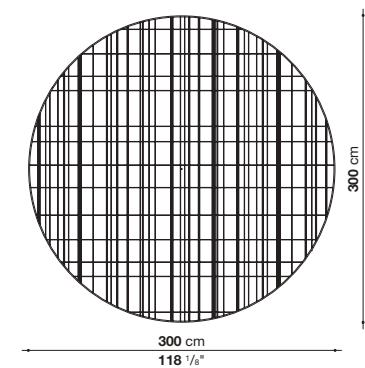

TPI250VL

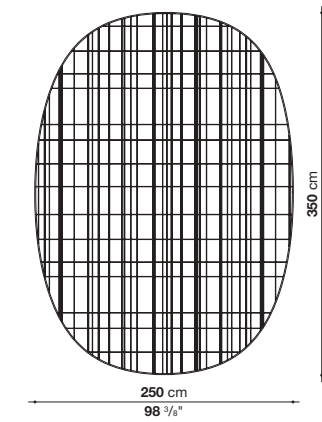

*TPI01

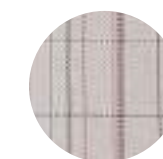
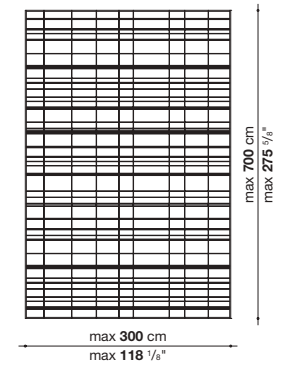

0072M
multicolour
multicolore



0037C
rope
corda



0046C
anthracite
antracite

The colours and materials shown are an indication. Images not in scale.
*Rectangular carpet per square meter. The minimum linear size in width realizable is 2,00 while the maximum size is 3,00 (for a total dimension up to 21 square meters).
La tonalità dei colori e dei materiali è indicativa. Immagini non in scala. *Tappeto rettangolare al metro quadrato. La dimensione minima lineare in larghezza realizzabile è 2,00 m mentre quella massima è 3,00 m (dimensione totale massima fino a 21 mq).

Pushpam

Naoto Fukasawa • 2018

Inspiration • 226



A collection of dining tables with small sizes and small tables that stand out for their perfect formal balance and for the striking texture of their cement finish, available in white or greige. "Many years ago, I called my chairs Papilio because their silhouettes reminded me of butterflies. Now I have called my latest project Pushpam (flower in Indonesian), because the Papilio Shell chairs sit around these tables like butterflies flying around a flower. The combination of a Pushpam table with the Papilio chairs creates a pleasant outdoor environment for a coffee or a quick meal. This was made possible by the use of a special cement moulding technology. We also added pigments so as to match the tables to the shell of the Papilio Shell chairs." (Naoto Fukasawa)

Una collezione di tavoli da pranzo di piccole dimensioni e di tavolini che si caratterizzano per il perfetto equilibrio formale e la forte matericità della finitura in cemento, in due varianti colore, greige e bianco. "Molti anni fa ho chiamato le mie sedie Papilio, perché la loro silhouette evocava le farfalle. Ora ho chiamato questo nuovo tavolo Pushpam (fiore in indonesiano), perché è un tavolo a cui le Papilio Shell stanno intorno come le farfalle volano intorno al Pushpam. Credo che questa introduzione di Pushpam insieme alle sedie Papilio crei un bell'ambiente outdoor per un caffè o un pasto veloce. Ciò è stato possibile grazie all'utilizzo di una tecnologia di stampo in cemento. Abbiamo aggiunto anche i pigmenti corretti per l'abbinamento con i colori delle scocche delle Papilio Shell." (Naoto Fukasawa)

Top and base-frame	cement (Ultra High Performance Concrete)	Piano e base	cemento (Ultra High Performance Concrete)
Coupling plate	galvanized sheet	Piastra di aggancio	lamiera zincata
Ferrules	thermoplastic material	Puntali	materiale termoplastico

Tables

Tavoli

TF85A

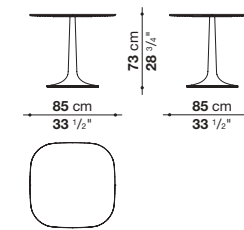

TF100RA

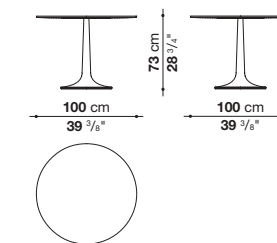

Small tables

Tavolini

TF85B

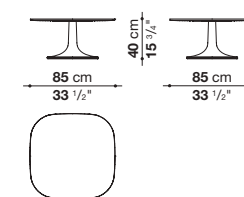

TF100RB

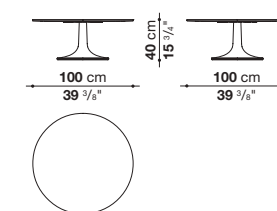

Top and base-frame

Piano e base



0159B
white cement
cemento bianco



0240G
greige cement
cemento greige

The colours and materials shown are an indication. Images not in scale.
La tonalità dei colori e dei materiali è indicativa. Immagini non in scala.

Ray Outdoor Fabric

Antonio Citterio • 2017

Inspiration • 138



Ray Outdoor Fabric features an interlacing ribbon pattern, created using polypropylene fibre that are resistant to UV rays and weathering. The range of colours, particularly suitable for outdoor environments, varies from turquoise to blue and from acid green to tortora through to bright bordeaux.

Ray Outdoor Fabric si distingue per l'intreccio a nastro, realizzato in fibra di polipropilene resistente ai raggi UV ed agli agenti atmosferici. La gamma di colori, particolarmente adatta agli ambienti outdoor, varia dal turchese al blu, dal verde acido al tortora sino ad un vivo colore bordeaux.

The "Fabric" collection consist of sofas available in two depths as well as modular elements such as terminal elements or chaise longue, armchair and a sunbed with wheels.

Le tipologie di seduta si compongono di divani in due profondità e di elementi componibili, dai terminali alle chaise longue, alla poltrona e al lettino con ruote.

Ray Outdoor Fabric

Antonio Citterio • 2017

Inspiration • 138

Sofas
Divani

RF235

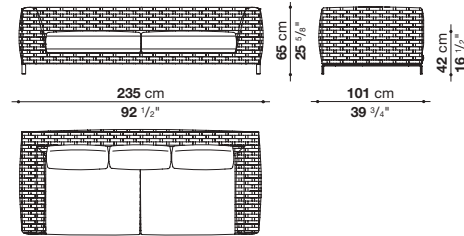

RFL235

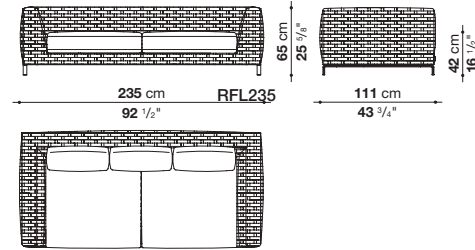

Armchair
Poltrona

RF85

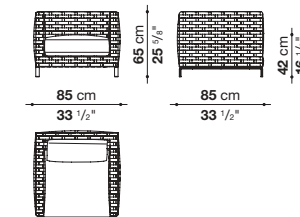

Terminal elements
Elementi terminali

* RF161D

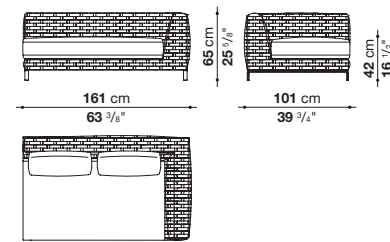

* RF235D

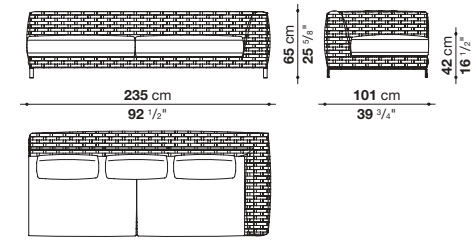

Sunbed with wheels and adjustable back
Letto con ruote e schienale regolabile

RF203LA

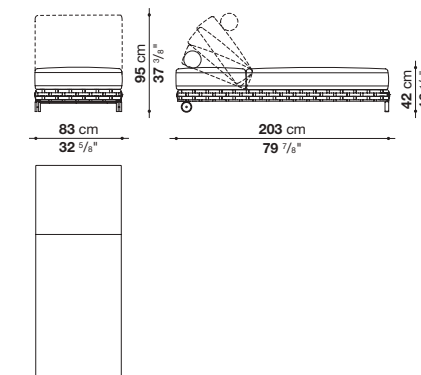

Chaise longue
Chaise longue

* RF161LD

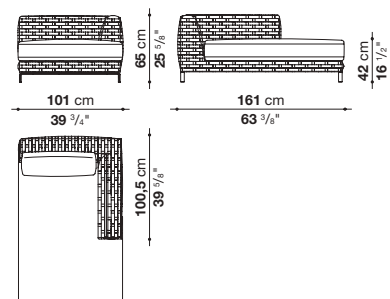

* RF235LD

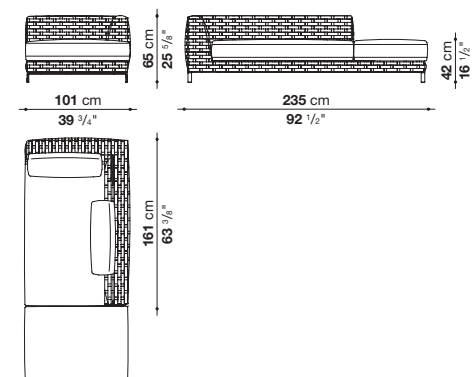

* Elements available in right and left version. / Elementi disponibili nella versione destra e sinistra.

Ray Outdoor Fabric

Antonio Citterio • 2017

Inspiration • 138

Internal frame	tubular aluminium and aluminium profiles with polyester powder painting
Upholstery	shaped polyurethane, Solutex fibre and visco-elastic polyurethane combination, cover in water repellent polyester fibre
Back cushion	polyester fibre, cover in water repellent polyester fibre
Interlacing	polypropylene fibre braid
Headrest cushion (RF203LA)	shaped polyurethane, cover in water repellent polyester fibre
Seat top (RF203LA)	HPL stratified laminate panel
Mechanism (RF203LA)	aluminium extrusion
Wheels (RF203LA)	steel and thermoplastic material
Feet	die-cast aluminium and extrusions with polyester powder painting
Ferrules	thermoplastic material
Waterproof cover cloth	PES fabric coated on one side in PU
Cover	fabric in limited categories

Telaio interno	tubolari e profilati d'alluminio con verniciatura a polvere poliesteri
Imbottitura	poliuretano sagomato, combinazione fibra Solutex e poliuretano viscoelastico, fodera in fibra di poliesteri con trattamento idrorepellente
Cuscino schienale	fibra di poliesteri, fodera in fibra di poliesteri con trattamento idrorepellente
Intreccio	treccia in fibra di polipropilene
Cuscino poggiatesta (RF203LA)	poliuretano sagomato, fodera in fibra di poliesteri con trattamento idrorepellente
Piano sedile (RF203LA)	pannello in laminato stratificato HPL
Meccanismo (RF203LA)	estruso d'alluminio
Ruote (RF203LA)	acciaio e materiale termoplastico
Piedini	fusione ed estrusi d'alluminio con verniciatura a polvere poliesteri
Puntali	materiale termoplastico
Telo di copertura impermeabile	tessuto PES monospalmato su un lato PU
Rivestimento	tessuto in categorie limitate

Interlacing

Intreccio



0787T
turquoise polypropylene polipropilene turchese



0880B
blue polypropylene polipropilene blu



0640V
acid green polypropylene polipropilene verde acido



0577B
bordeaux polypropylene polipropilene bordeaux



0428T
tortora polypropylene polipropilene tortora

Feet

Piedini

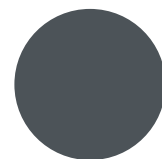

0236B
anthracite painted verniciato antracite

The colours and materials shown are an indication. Images not in scale.
La tonalità dei colori e dei materiali è indicativa. Immagini non in scala.

Product items/Prodotti

Recommended combinations/Abbinamenti suggeriti



2481820
Lesia



2481101
Lesia



2563810
Agate



0787T
turquoise polypropylene polipropilene turchese



2481255
Lesia



2481407
Lesia



0640V
acid green polypropylene polipropilene verde acido



2481820
Lesia



2481101
Lesia



2563810
Agate



0787T
turquoise polypropylene polipropilene turchese



2481207
Lesia



0577B
bordeaux polypropylene polipropilene bordeaux



2569101
Ermitage



0880B
blue polypropylene polipropilene blu



2481207
Lesia



0577B
tortora polypropylene polipropilene tortora

The colours and materials shown are an indication. Images not in scale.
La tonalità dei colori e dei materiali è indicativa. Immagini non in scala.

Ray Outdoor Natural

Antonio Citterio • 2017

Inspiration • 146



After its success indoors, the Ray seating system designed by Antonio Citterio now include two new outdoor versions, namely the “Natural” and “Fabric” collections of seats which stand out for their new interlacings and materials.

Dopo il successo in ambito indoor, il sistema di sedute Ray di Antonio Citterio si veste per l'outdoor con due famiglie di sedute, “Natural” e “Fabric” che si distinguono per differenti intrecci e materiali.

Ray Outdoor Natural features an interlacing rope pattern reminiscent of Manila hemp, in perfect harmony with nature, and is created with textilene, making it perfect for outdoor use.

La famiglia Ray Outdoor Natural è caratterizzata da un intreccio a “corda” che si rifà all'abaca naturale, in perfetta armonia con la natura, ed utilizza textilene perfettamente adatto agli ambienti esterni.

Ray Outdoor Natural
Antonio Citterio • 2017
Inspiration • 146



Ray Outdoor Natural is available with an extruded aluminium feet or teakwood base. The “Natural” collection consists of sofas available in two depths as well as modular elements such as terminal elements, chaise longue and armchair.

Ray Outdoor Natural è disponibile sia con piedini in estruso d'alluminio che nella versione con basamento in teak. Le tipologie di seduta si compongono di divani in due profondità e di elementi componibili, dai terminali alle chaise longue e poltrona.

Ray Outdoor Natural

Antonio Citterio • 2017

Inspiration • 146

Sofas with metal feet
Divani con piedini metallici

RN236

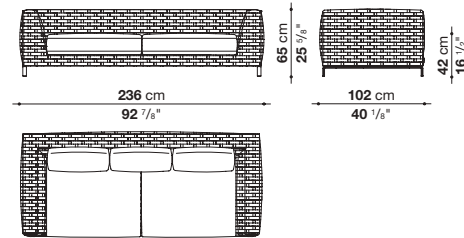

RNL236

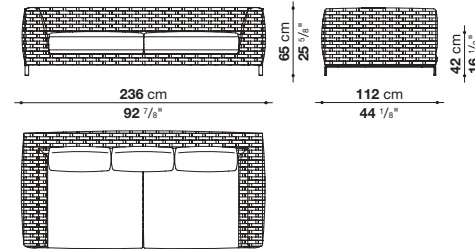

Sofas with wooden base
Divani con base in legno

RN236_B

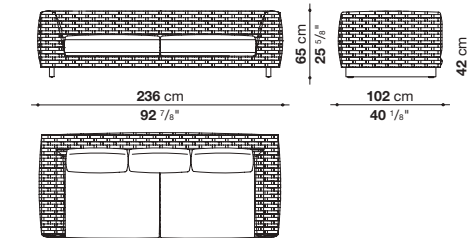

RNL236_B

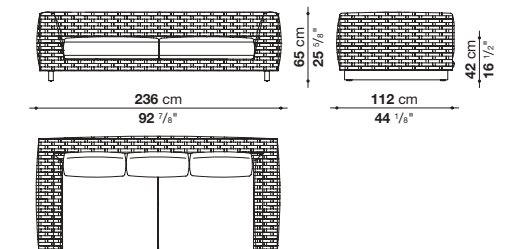

Terminal element with metal feet
Elemento terminale con piedini metallici

* RN236D

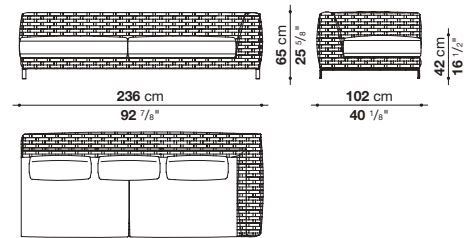

Chaise longue with metal feet
Chaise longue con piedini metallici

* RN236LD

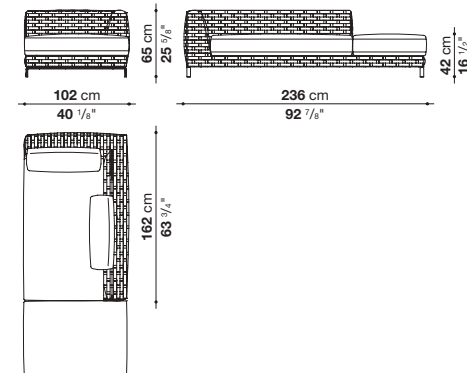

Terminal element with wooden base
Elemento terminale con base in legno

* RN236D_B

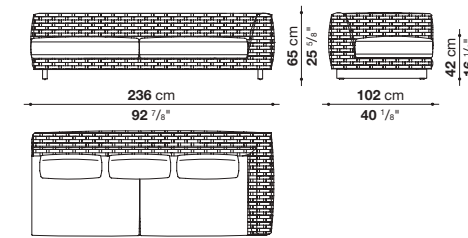

Chaise longue with wooden base
Chaise longue con base in legno

* RN236LD_B

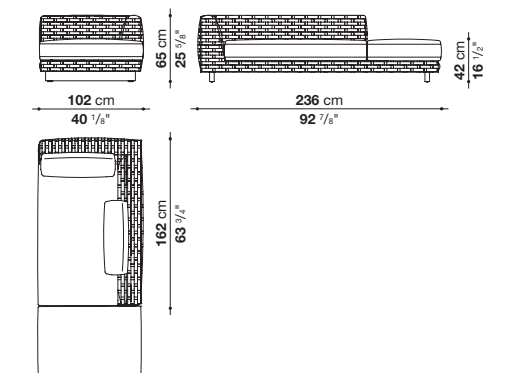

Armchair with metal feet
Poltrona con piedini metallici

RN86

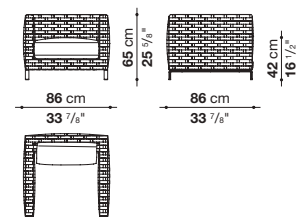

Armchair with wooden base
Poltrona con base in legno

RN86_B

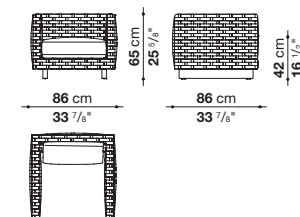

* Elements available in right and left version. / Elementi disponibili nella versione destra e sinistra.

* Elements available in right and left version. / Elementi disponibili nella versione destra e sinistra.

Ray Outdoor Natural

Antonio Citterio • 2017

Inspiration • 146

Internal frame	tubular aluminium and aluminium profiles with polyester powder painting
Upholstery	shaped polyurethane, Solotex fibre and visco-elastic polyurethane combination, cover in water repellent polyester fibre
Back cushion	polyester fibre, cover in water repellent polyester fibre
Interlacing	textilene braid
Feet	die-cast aluminium and extrusions with polyester powder painting
Base	solid wood
Ferrules	thermoplastic material
Waterproof cover cloth	PES fabric coated on one side in PU
Cover	fabric in limited categories

Telaio interno	tubolari e profilati d'alluminio con verniciatura a polvere poliestere
Imbottitura	poliuretano sagomato, combinazione fibra Solotex e poliuretano viscoelastico, fodera in fibra di poliestere con trattamento idrorepellente
Cuscino schienale	fibra di poliestere, fodera in fibra di poliestere con trattamento idrorepellente
Intreccio	treccia in textilene
Piedini	fusione ed estrusi d'alluminio con verniciatura a polvere poliestere
Base	legno massello
Puntali	materiale termoplastico
Telo di copertura impermeabile	tessuto PES monospalmato su un lato PU
Rivestimento	tessuto in categorie limitate

Interlacing Intreccio



0528N
natural colour
textilene
textilene color naturale

Feet Piedini

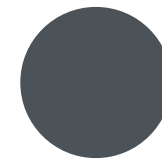

0236B
anthracite painted
verniciato antracite

Base Base

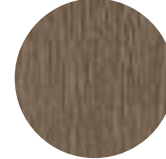

0492T
antique grey teakwood
teak antique grey

The colours and materials shown are an indication. Images not in scale.
La tonalità dei colori e dei materiali è indicativa. Immagini non in scala.

Product items/Prodotti

Recommended combinations/Abbinamenti suggeriti



2481280
Lesia



2481207
Lesia



2563257
Agate



0236B
anthracite
painted
verniciato
antracite



0528N
natural colour
textilene
textilene color
naturale



2481305
Lesia



2563257
Agate



0236B
anthracite
painted
verniciato
antracite



0528N
natural colour
textilene
textilene color
naturale



2481280
Lesia



2481207
Lesia



2563257
Agate



0492T
antique grey
teakwood
teak antique
grey



0528N
natural colour
textilene
textilene color
naturale



2481305
Lesia



2563257
Agate



0492T
antique grey
teakwood
teak antique
grey



0528N
natural colour
textilene
textilene color
naturale



2481830
Lesia



0236B
anthracite
painted
verniciato
antracite



0528N
natural colour
textilene
textilene color
naturale



2481280
Lesia



2481207
Lesia



2563257
Agate



0236B
anthracite
painted
verniciato
antracite



0528N
natural colour
textilene
textilene color
naturale

The colours and materials shown are an indication. Images not in scale.
La tonalità dei colori e dei materiali è indicativa. Immagini non in scala.

Ribes

Antonio Citterio • 2019

Inspiration • 86



Ribes is a modular seating system designed by Antonio Citterio with a focus on versatility, customisation, colour and research on materials. Sofas, central and end elements, chaises longues and ottomans all come in a huge variety of shapes and sizes that lend themselves to being arranged in an outdoor space according to personal taste thanks to the exceptional versatility of the modular components and the availability of a vast range of covers and finishes.

Ribes è un sistema di sedute componibili disegnato da Antonio Citterio, che mette al centro del progetto i temi della flessibilità, della personalizzazione, del colore e della ricerca sui materiali. Divani, elementi centrali e terminali, chaise longue e pouf, proposti in numerose tipologie e dimensioni, consentono di interpretare lo spazio outdoor in maniera molto personale grazie all'estrema flessibilità compositiva e alla possibilità di scegliere tra numerosissimi rivestimenti e finiture.

The starting point is a futon base with flexible glass-fibre slats resting on an aluminium frame to which two types of arm or back rest can be attached as desired: one with a polypropylene fibre interlacing, the other with a roller cushion.

Il punto di partenza è una base "futon" con doghe flessibili in fibra di vetro, appoggiate su una struttura in alluminio, sulla quale fissare liberamente braccioli e schienali previsti in due tipologie: a telaio con intreccio in fibra di polipropilene oppure a rullo.

Ribes

Antonio Citterio • 2019

Inspiration • 86



The seating system is enriched with seat cushions intended as comfortable mattresses to stretch out on and several shapes of back- and armrest cushion, all containing a new filling giving Ribes a particularly lived-in and soft look.

Colour comes into play in the painted frames in shades of anthracite, sage and clay. These same tones are then picked up in the back and arm supports combining the colours sage and clay with a natural-coloured interlacing and anthracite to one in a matching shade, and the same for the brackets of the roller sections.

Il sistema di sedute si arricchisce di cuscini sedile pensati come comodi materassi dove rilassarsi e varie tipologie di cuscini schienale e bracciolo, tutti realizzati con una nuova imbottitura che dona a Ribes un aspetto vissuto particolarmente morbido.

Il tema del colore viene introdotto dalle strutture verniciate nelle tonalità antracite, salvia e argilla.

Queste nuance sono riprese dagli schienali e braccioli a telaio, che abbinano il salvia e l'argilla ad un intreccio naturale e l'antracite ad un intreccio tono su tono ed ai supporti delle versioni a rullo.

Because it is so versatile, Ribes can also be reconfigured over time by adding new elements as well as altering the functional use of existing ones. By substituting, adding or varying the position of the back and armrests, a sommier can turn into a vis-à-vis sofa, a sofa become an island and a corner seating plan transform into a comfortable bed. Ribes means transformation and is especially suited to those areas that are neither in-nor outside: verandas, shady patios, under a loggia or on a covered terrace allowing a fluid approach to the open spaces in the home.

Grazie alla flessibilità del sistema, Ribes può essere modificato nel tempo aggiungendo nuovi elementi, ma anche cambiando la funzione d'uso di quello esistenti. Sostituendo, aggiungendo o modificando la posizione di schienali e braccioli, un sommier può diventare un vis-à-vis, un divano può diventare un'isola, un angolare può diventare un comodo letto. Una natura trasformabile quella di Ribes, che si trova particolarmente a suo agio negli spazi di passaggio tra interno ed esterno, nelle verande o all'ombra di un patio, sotto un loggiato o un terrazzo coperto, per vivere con fluidità la casa e gli spazi aperti.

Ribes
Antonio Citterio • 2019
Inspiration • 86

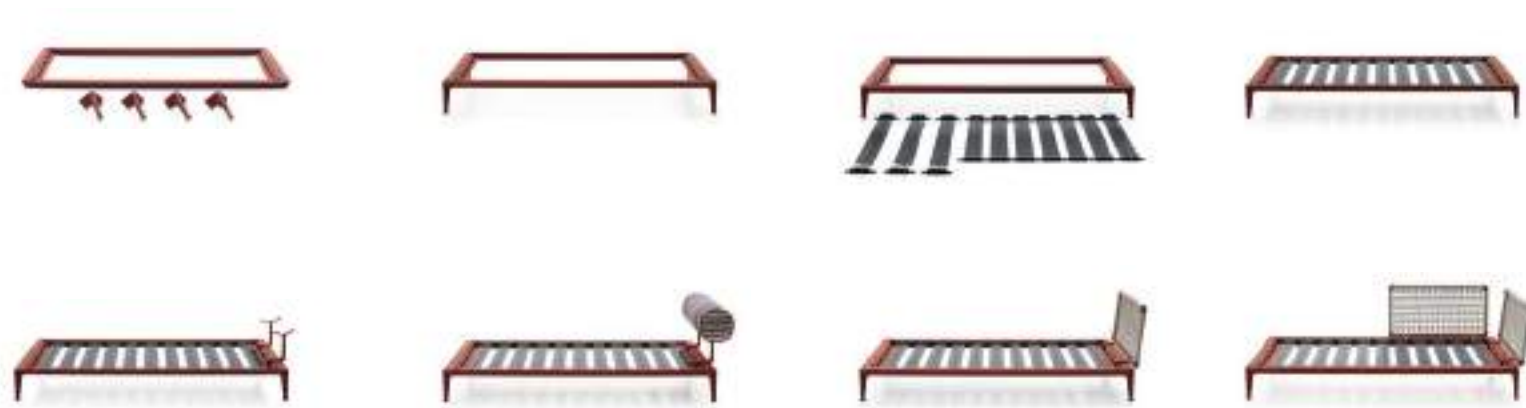

The Ribes sofa has several strengths including total disassembly, the possibility of storing the product for winter time, modularity and multiple configurations.

Il divano Ribes ha diversi punti di forza tra cui il totale disassemblaggio, la possibilità di essere stoccato per l'inverno, la componibilità e le molteplici configurazioni.

Sofas
Divani

RB212

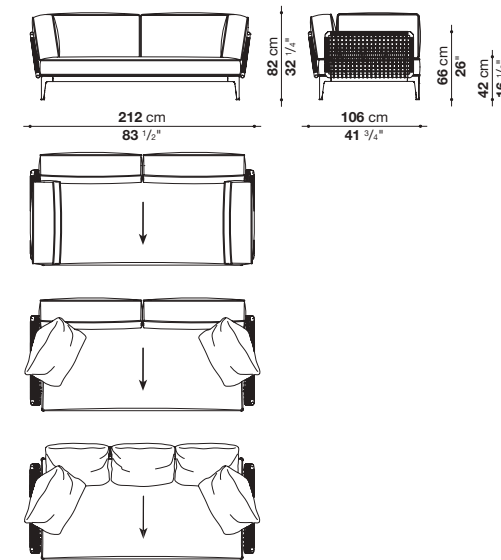

RBR220

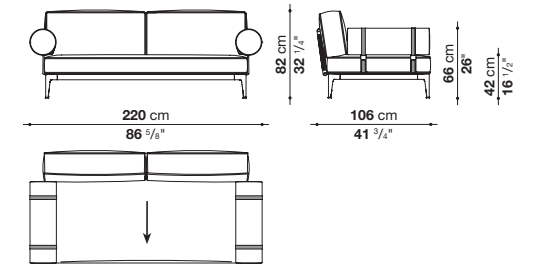

RB248

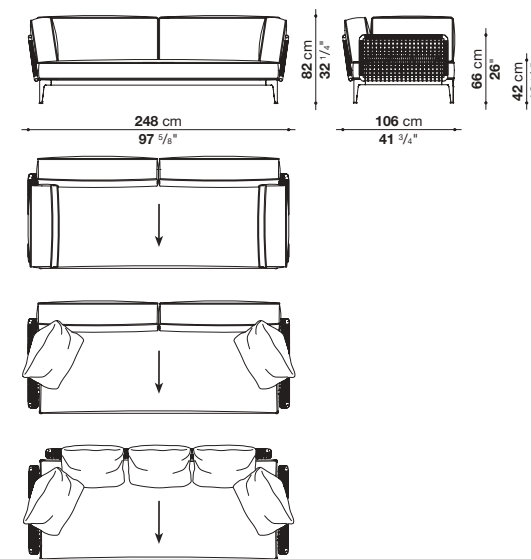

RBR256

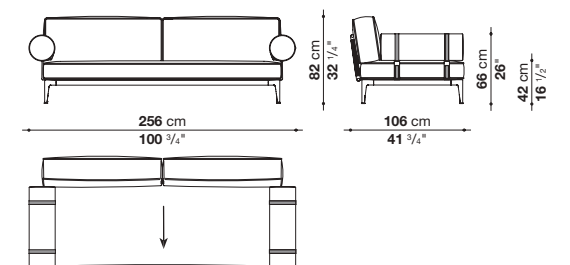

In the drawing the arrow shows the direction of the lines in case of cover with striped fabrics. Nel disegno la freccia indica la direzione delle righe in caso di rivestimento con tessuti rigati.

Ribes

Antonio Citterio • 2019

Inspiration • 86

Central elements

Elementi centrali

RB190C

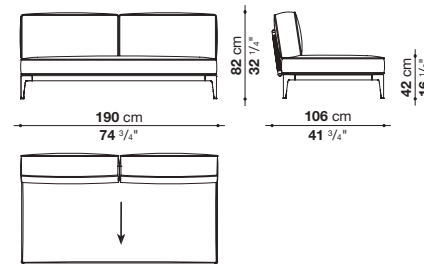

RBR190C

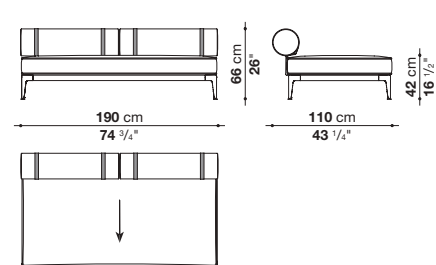

Terminal elements

Elementi terminali

RB201T_1

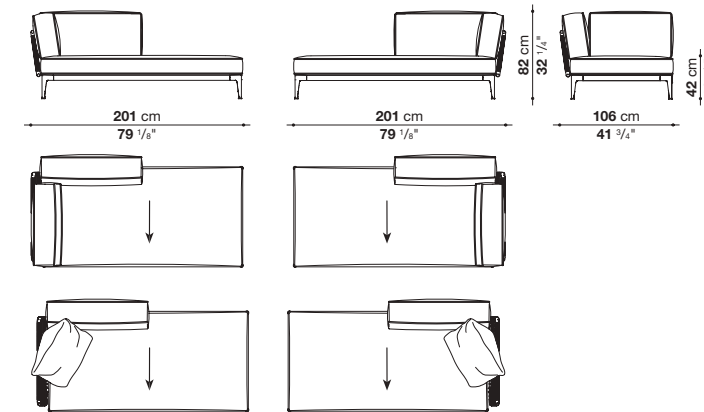

RBR205T_1

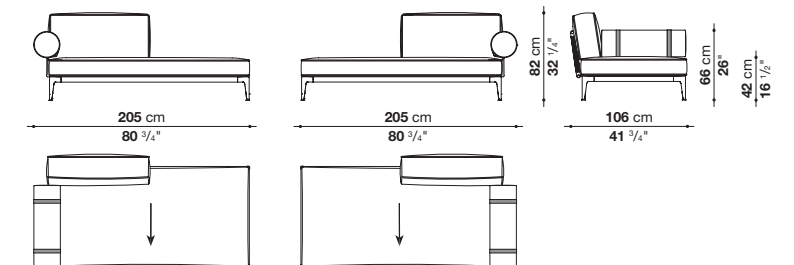

Benches

Panche

RB190PA_1

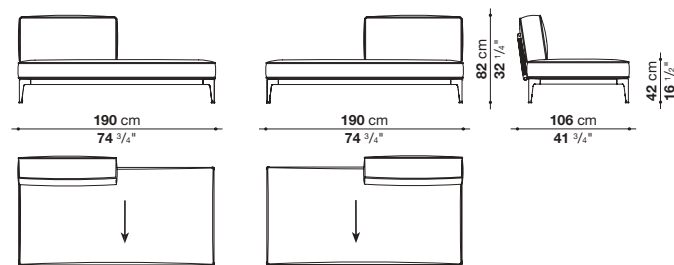

RB190PA

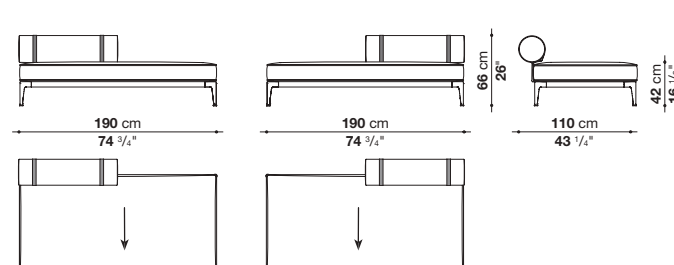

RB201T_2

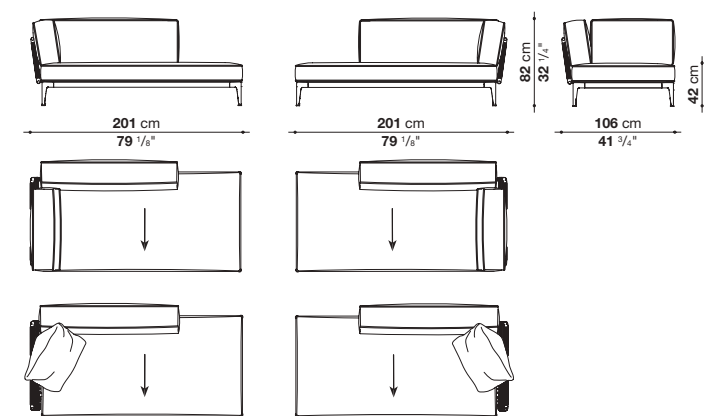

RBR205T_2

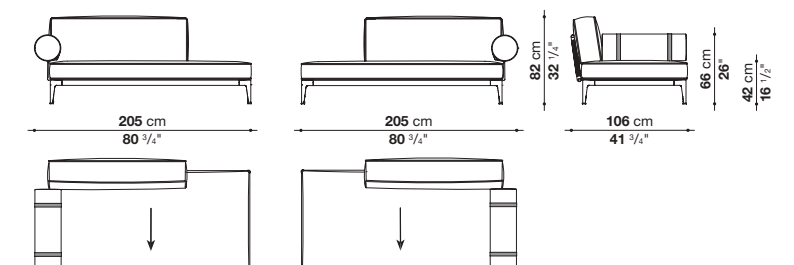

RB190PA_2

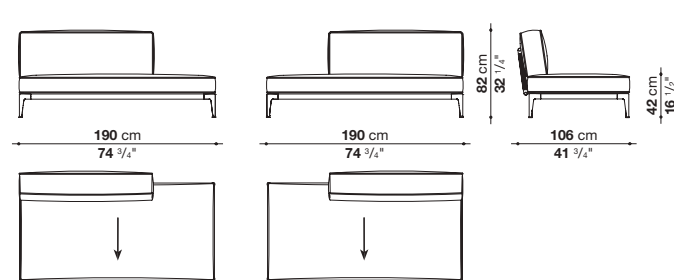

RB190PA_3

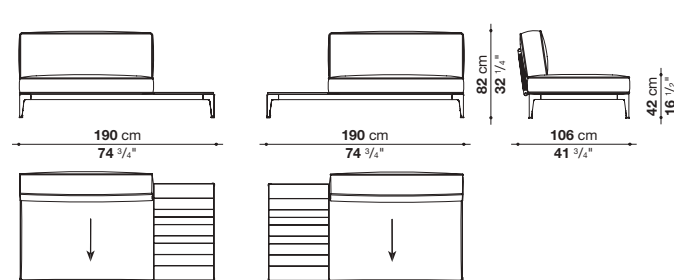

RB201T_3

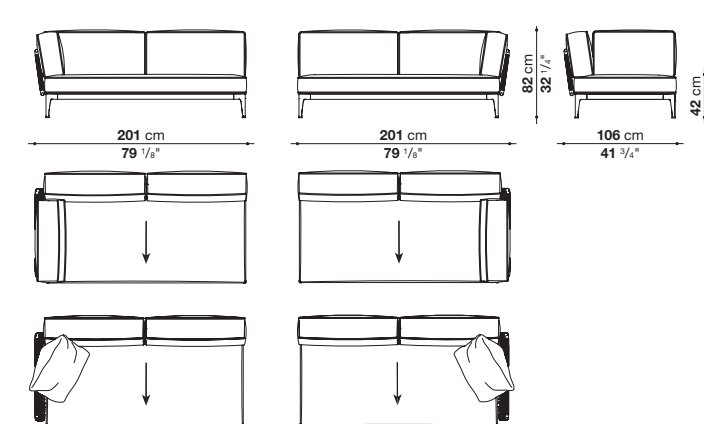

RBR205T_3

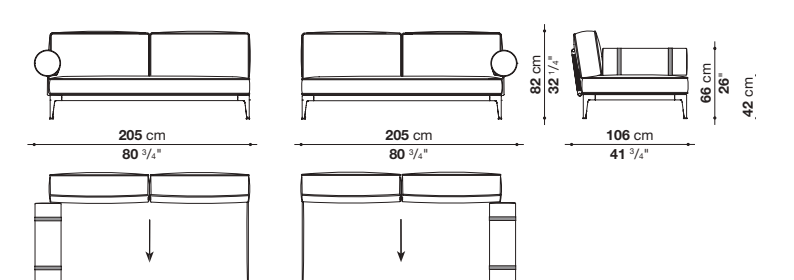

In the drawing the arrow shows the direction of the lines in case of cover with striped fabrics.
 Nel disegno la freccia indica la direzione delle righe in caso di rivestimento con tessuti rigati.

In the drawing the arrow shows the direction of the lines in case of cover with striped fabrics.
 Nel disegno la freccia indica la direzione delle righe in caso di rivestimento con tessuti rigati.

Ribes

Antonio Citterio • 2019

Inspiration • 86

Terminal elements
Elementi terminali

RBR205T_4

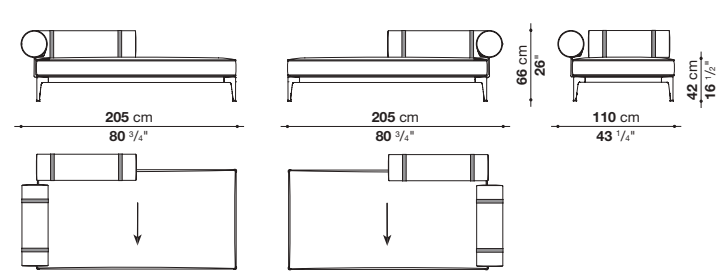

RBR205T_5

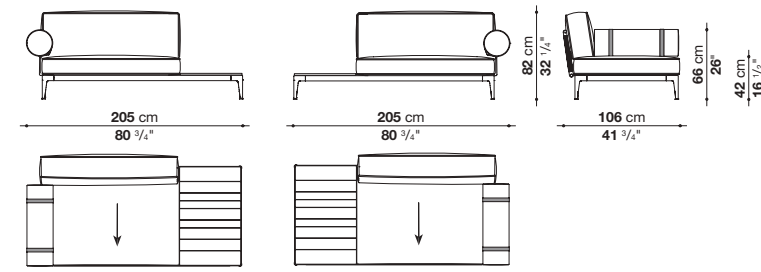

RB201T_4

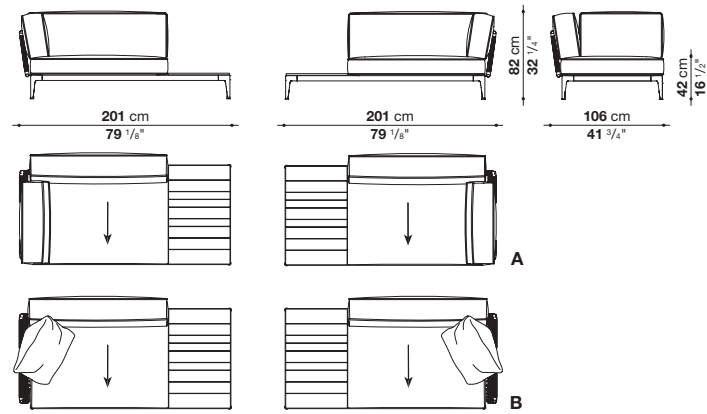

Chaise longue
Chaise longue

RB141L_1

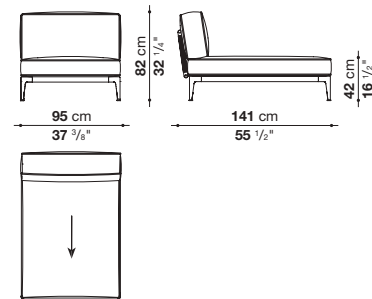

RBR145L

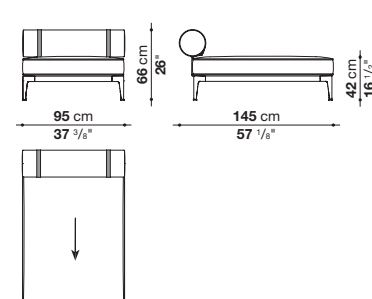

RB141L_2

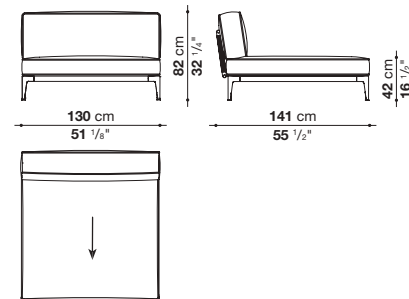

In the drawing the arrow shows the direction of the lines in case of cover with striped fabrics.
Nel disegno la freccia indica la direzione delle righe in caso di rivestimento con tessuti rigati.

Chaise longue
Chaise longue

RB201L

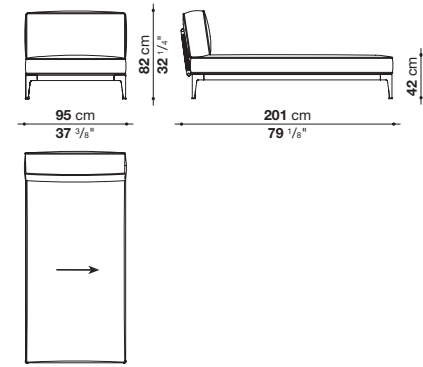

RBR205L

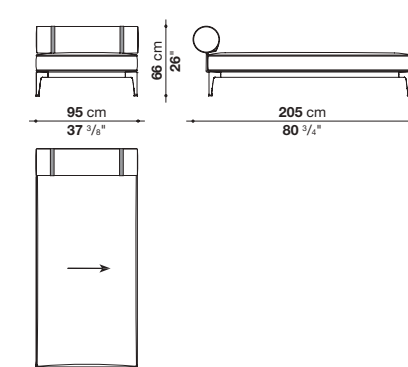

RBR145LB_1

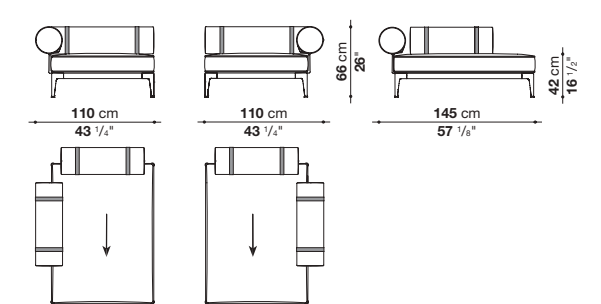

RB141LB_1

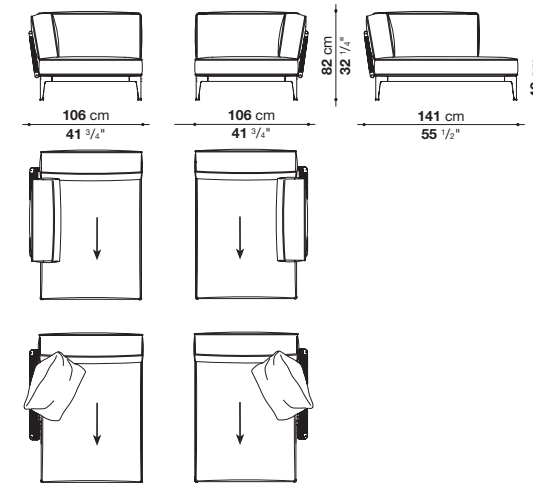

RBR141LB_1

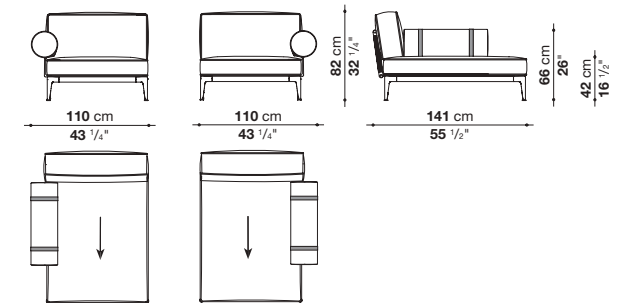

RBR141LB_2

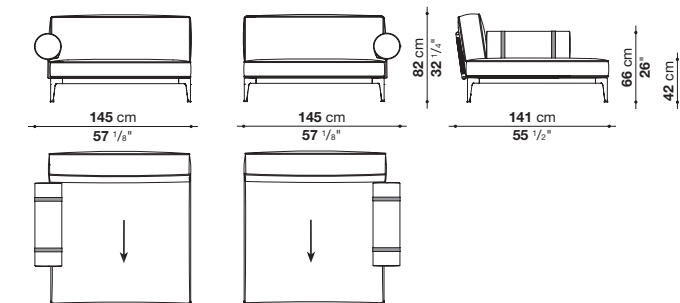

RBR145LB_2

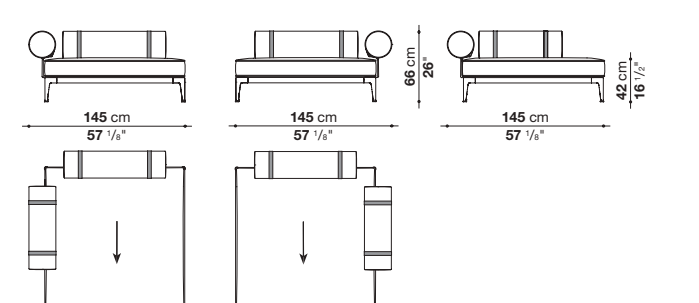

In the drawing the arrow shows the direction of the lines in case of cover with striped fabrics.
Nel disegno la freccia indica la direzione delle righe in caso di rivestimento con tessuti rigati.

Ribes

Antonio Citterio • 2019

Inspiration • 86

Chaise longue
Chaise longue

RB141LB_3

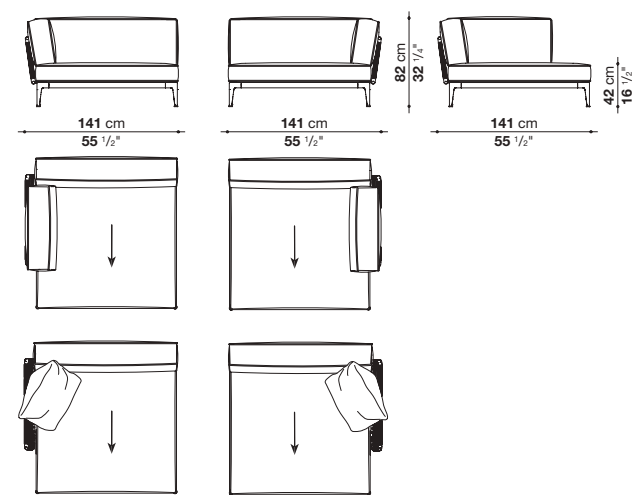

RB201LB_1

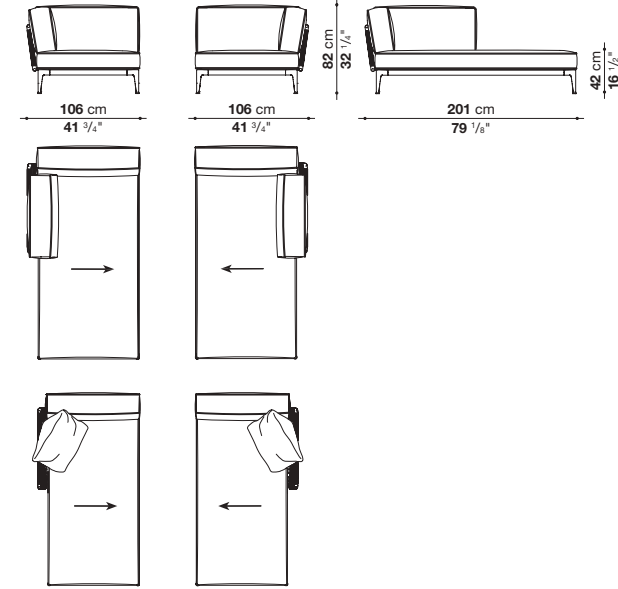

Chaise longue
Chaise longue

RB201LB_2

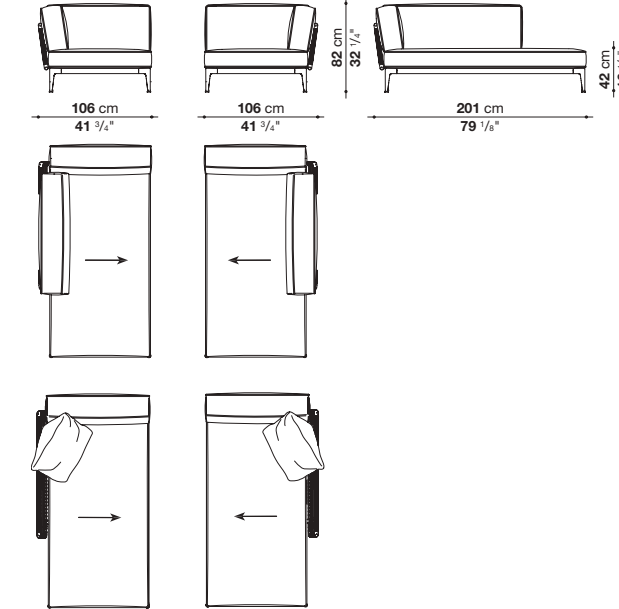

RB141LB_4

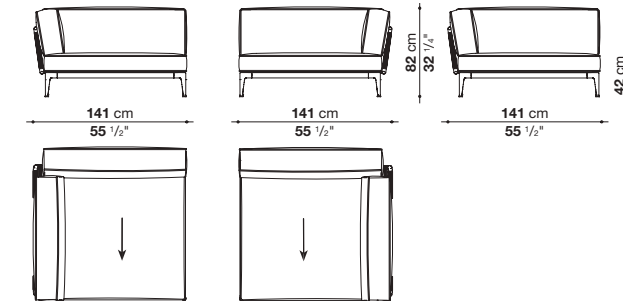

RBR201LB

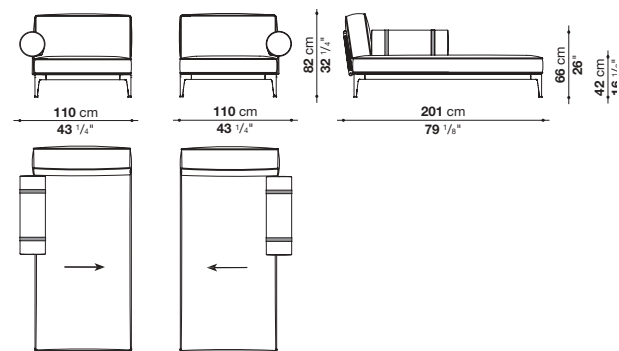

RB141LB_2

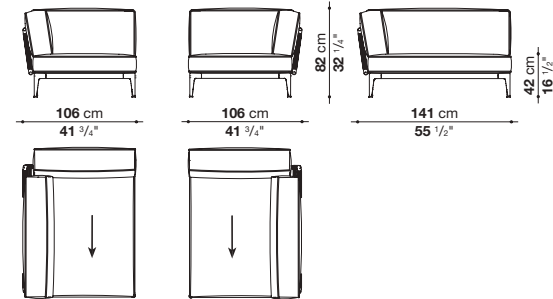

RB141LB_6

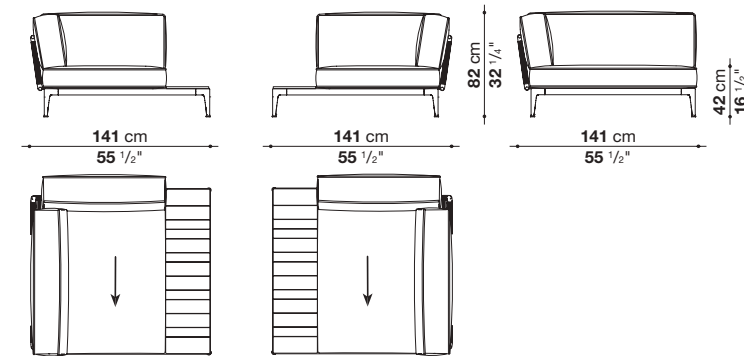

RB141L_3

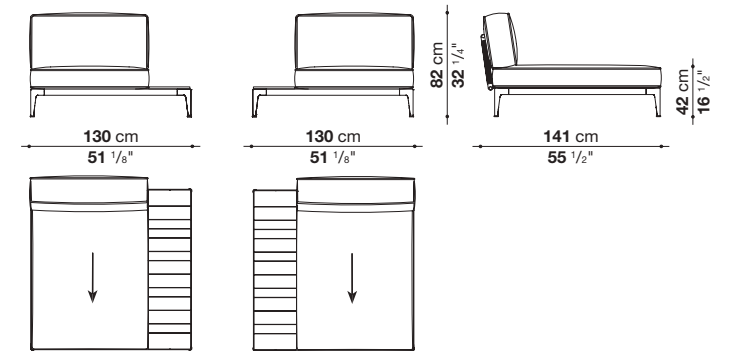

RBR141LB_3

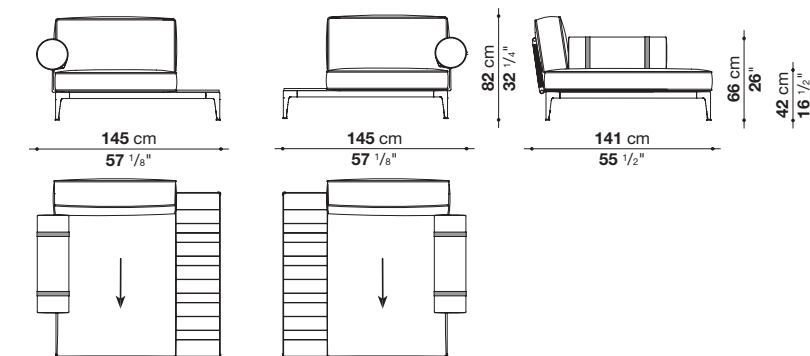

In the drawing the arrow shows the direction of the lines in case of cover with striped fabrics.
Nel disegno la freccia indica la direzione delle righe in caso di rivestimento con tessuti rigati.

In the drawing the arrow shows the direction of the lines in case of cover with striped fabrics.
Nel disegno la freccia indica la direzione delle righe in caso di rivestimento con tessuti rigati.

Ribes

Antonio Citterio • 2019

Inspiration • 86

Chaise longue

Chaise longue

RB141LB_5

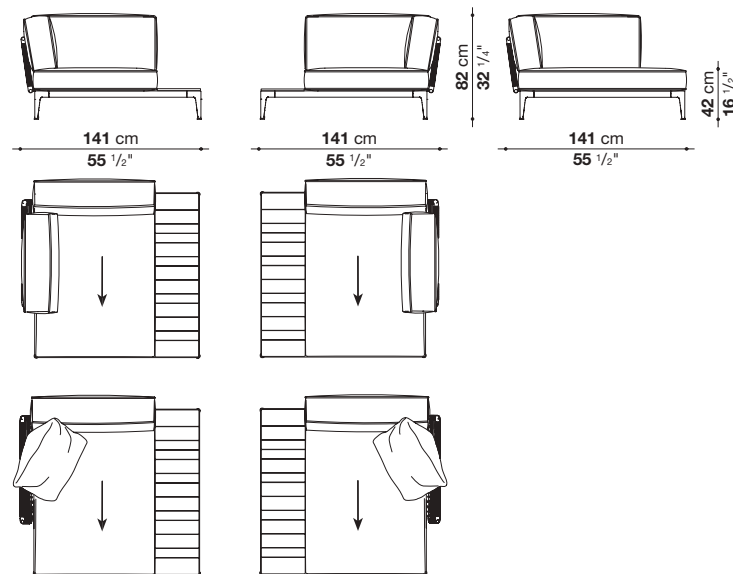

RB201LB_3

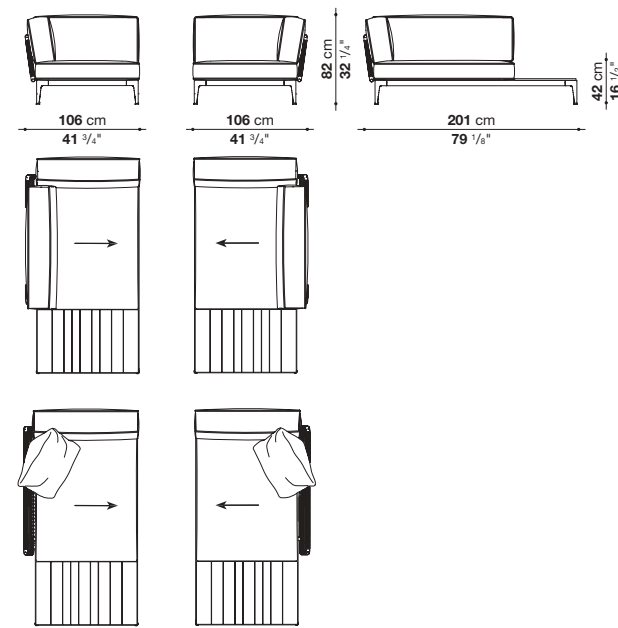

Ottomans

Pouf

RB130P_1

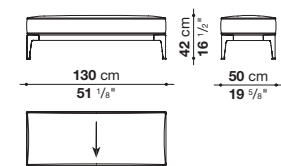

RB130P_2

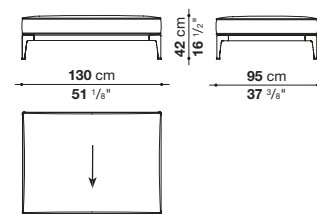

RB130PQ

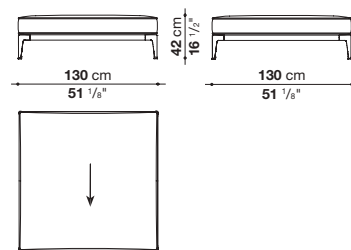

RB190P

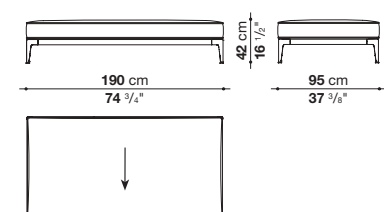

RB130PQ_1

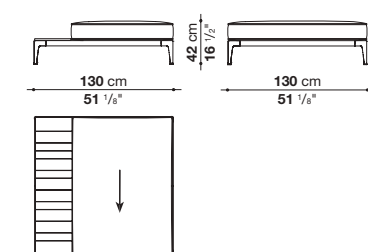

RB190P_1

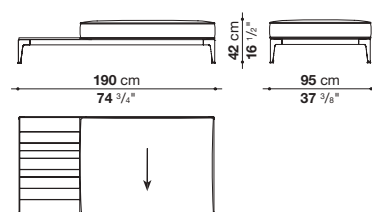

In the drawing the arrow shows the direction of the lines in case of cover with striped fabrics.
Nel disegno la freccia indica la direzione delle righe in caso di rivestimento con tessuti rigati.

Frame	die-cast aluminium and extrusions with polyester powder painting
Back and roller upholstery	recycled polyester fibre from PET, cover in water repellent polyester fibre
Seat upholstery	shaped polyurethane, recycled polyester fibre from PET, cover in water repellent polyester fibre
Interlacing	polypropylene fibre braid
Seat slats	glass fibre
Seat top section	solid wood
Ferrules	thermoplastic material
Waterproof cover cloth	PES fabric coated on one side in PU
Cover	fabric in limited categories (with profile)

Struttura	pressofusione ed estrusi d'alluminio con verniciatura a polvere poliestere
Imbottitura schienale e rullo	fibra di poliestere riciclata da PET, fodera in fibra di poliestere con trattamento idrorepellente
Imbottitura sedile	poliuretano sagomato, fibra di poliestere riciclata da PET, fodera in fibra di poliestere con trattamento idrorepellente
Intreccio	treccia in fibra di polipropilene
Doghe seduta	fibra di vetro
inserto piano seduta	legno massello
Puntali	materiale termoplastico
Telo di copertura impermeabile	tessuto PES monospalmato su un lato PU
Rivestimento	tessuto in categorie limitate (con profilo)

Frame and interlacing matching

Abbinamento struttura e intreccio

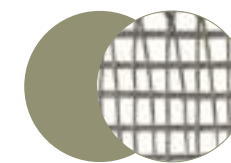

0431S

sage frame / natural polypropylene
struttura salvia / polipropilene naturale

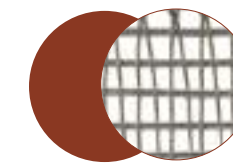

0721A

clay frame / natural polypropylene
struttura argilla / polipropilene naturale

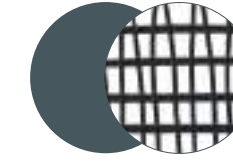

0132N

anthracite frame / anthracite polypropylene
struttura antracite / polipropilene antracite

Frame

Struttura

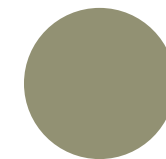

0427S

sage painted
verniciato salvia

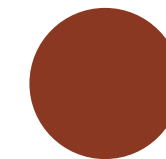

0750A

clay painted
verniciato argilla

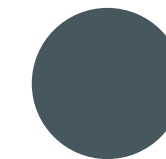

0236B

anthracite painted
verniciato antracite

Seat, back cushion profile and roller webbing

Profilo cuscino sedile, schienale e cinghe rullo

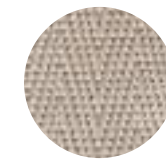

0041E

cream white
bianco panna

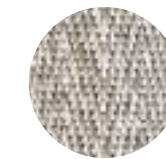

0082N

natural
naturale

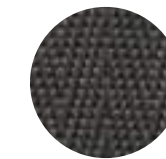

0054G

dark grey
grigio scuro

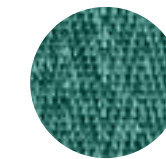

00585A

aquamarine
acquamarina

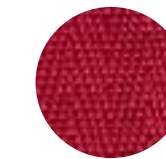

0075R

red
rosso

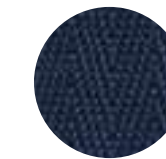

0095B

blue
blu

The colours and materials shown are an indication. Images not in scale.
La tonalità dei colori e dei materiali è indicativa. Immagini non in scala.

Ribes

Antonio Citterio • 2019

Inspiration • 86

The textile choice is also extensive and colourful with designs that have been inspired by traditional fabrics collected during numerous trips to South America, reinterpreted and redesigned using very clear colour schemes that still leave a wide choice of different combinations allowing maximum customisation. The seat, back and arm cushions can be covered as desired in wide or narrow-striped, dotted or singlecolour material, all in various shades that coordinate with each other. Colored profiles, are available in cream white, natural, dark grey, aquamarine, red and blue, giving definition to the upholstery and allowing for a further degree of customization.

Anche la proposta tessile è ricca e colorata, con fantasie che si ispirano a tessuti tradizionali raccolti nel corso di numerosi viaggi in Sudamerica, reinterpretati e ridisegnati secondo schemi cromatici ben precisi, che lasciano tuttavia grande libertà di scelta negli abbinamenti così da offrire innumerevoli possibilità di personalizzazione. I cuscini sedile, schienale e bracciolo possono essere vestiti a piacere con tessuti a righe larghe, righe strette, puntinati e uniti, tutti in varie tonalità tra loro coordinabili. Profili colorati, da scegliere tra il bianco panna, naturale, grigio scuro, acquamarina, rosso e blu sottolineano i rivestimenti e consentono un ulteriore grado di personalizzazione.

2570810
Elisir

2563800
Agate

2570820
Elisir

2570815
Elisir

0095B
blue webbing
and profile
cinghie e
profilo blu

0721A
clay frame
struttura
argilla



2570110
Elisir

2570207
Elisir

2570115
Elisir

2570120
Elisir

0075R
red webbing
and profile
cinghie e
profilo rosso

0431S
sage frame
struttura
salvia



2569840
Ermitage

2570715
Elisir

2563700
Agate

2570720
Elisir

0082N
natural webbing
and profile
cinghie e
profilo naturale

0132N
anthracite frame
struttura
antracite



Ribes

Antonio Citterio • 2019

Inspiration • 86

Product compositions/Esempi di composizioni
Recommended combinations/Abbinamenti suggeriti



2570810	2570815	2570820	0721A
Elisir	Elisir	Elisir	clay frame natural polypropylene struttura argilla polipropilene naturale
2570207	0075R		
Elisir	red profile/profilo rosso		



2570810	2570815	2570820	0721A
Elisir	Elisir	Elisir	clay frame natural polypropylene struttura argilla polipropilene naturale
0075R			
red profile/profilo rosso			



2570810	2570815	2570820	0721A
Elisir	Elisir	Elisir	clay frame natural polypropylene struttura argilla polipropilene naturale
2570207	0075R		
Elisir	red profile/profilo rosso		



2570715	2570315	2570310	0750A
Elisir	Elisir	Elisir	clay painted verniciato argilla
0075R			
red profile/profilo rosso			



2570410	2570415	2570420	0431S
Elisir	Elisir	Elisir	sage frame natural polypropylene struttura salvia polipropilene naturale
0082N			
natural profile/profilo naturale			



2570810	2570815	2570820	0456T	0721A
Elisir	Elisir	Elisir	natural teakwood teak naturale	clay frame natural polypropylene struttura argilla polipropilene naturale
2570207	0082N			
Elisir	natural profile/profilo naturale			



2570810	2570815	2570820	0750A	0456T
Elisir	Elisir	Elisir	clay painted verniciato argilla	natural teakwood teak naturale
0075R				
red profile/profilo rosso				



2570815	2570120	2530795	0750A	0456T
Elisir	Elisir	Loreo	clay painted verniciato argilla	natural teakwood teak naturale
2570207	0075R			
Elisir	red profile/profilo rosso			



2570207	2570810	2570820	0721A
Elisir	Elisir	Elisir	clay frame natural polypropylene struttura argilla polipropilene naturale
0082N			
natural profile/profilo naturale			



2570410	2570415	2570420	0431S
Elisir	Elisir	Elisir	sage frame natural polypropylene struttura salvia polipropilene naturale
0082N			
natural profile/profilo naturale			



2570110	2570115	2570120	0236B
Elisir	Elisir	Elisir	anthracite painted verniciato antracite
2570207	0075R		
Elisir	red profile/profilo rosso		



2570810	2570815	2570820	0750A
Elisir	Elisir	Elisir	clay painted verniciato argilla
2570207	0075R		
Elisir	red profile/profilo rosso		

The colours and materials shown are an indication. Images not in scale.
La tonalità dei colori e dei materiali è indicativa. Immagini non in scala.

The colours and materials shown are an indication. Images not in scale.
La tonalità dei colori e dei materiali è indicativa. Immagini non in scala.

Spool Outdoor

Piero Lissoni • 2020
Inspiration • 234



Spool, born as indoor product, maintains its recognizable shape and it is now proposed in the stoneware outdoor version, available in six different vivid colours: white, anthracite, dove grey, sage, clay or ocean blue and it represents a lively punctuation.

Spool, nato nella versione indoor, mantiene la sua forma riconoscibile e viene ora proposto nella versione Outdoor, in gres, declinato in sei varianti di colore dalle vivaci tonalità: bianco, antracite, tortora, salvia, argilla o blu oceano, rappresenta una punteggiatura vivace.

Frame and top	stoneware	Struttura e piano	gres
Fixing bracket	stainless steel	Barra di fissaggio	acciaio inox
Ferrules	thermoplastic material	Puntali	materiale termoplastico

Small table Tavolino

OS40T

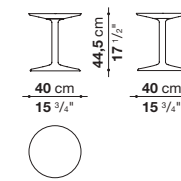

Top and base-frame Piano e basamento

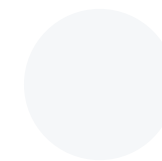

0245B
glossy white stoneware
gres bianco lucido

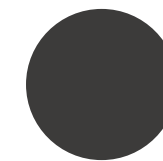

0309A
glossy anthracite stoneware
gres antracite lucido

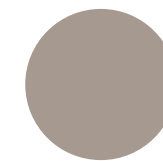

0613T
glossy dove grey stoneware
gres tortora lucido



0841S
glossy sage stoneware
gres salvia lucido

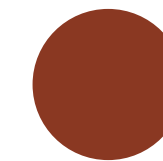

0784A
glossy clay stoneware
gres argilla lucido

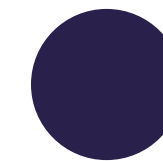

0829B
glossy ocean blue stoneware
gres blu oceano lucido

The colour shown are an indication. Image not in scale.
La tonalità del colore è indicativa. Immagine non in scala.

Springtime

Jean-Marie Massaud • 2008

Inspiration • 256



The Springtime complements are available in three different sizes all with a rounded shape and are made of water-repellent material. The products are designed by Jean-Marie Massaud as furnishing elements of an outdoor area that conceptually dialogues between nature and interior spaces.

Realizzati in materiale idrorepellente, i complementi Springtime sono disponibili in tre diverse dimensioni e forme, seppur tutte arrotondate. Sono pensati da Jean-Marie Massaud come elementi di arredo di un'area esterna che dialoga concettualmente tra natura e spazi interni della casa.

Frame and top	Cristalplant Outdoor® (natural mineral filler of phosphate of aluminium with polyester acrylate resin)	Struttura e piano	Cristalplant Outdoor® (carica minerale naturale di idrato d'alluminio con resina poliestere acrilata)
Feet	stainless steel	Piedini	acciaio inossidabile

Small tables Tavolini

TST4

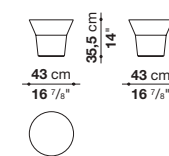

TST7

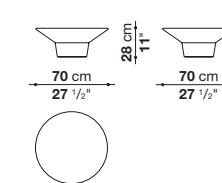

Vase Vaso

TST11

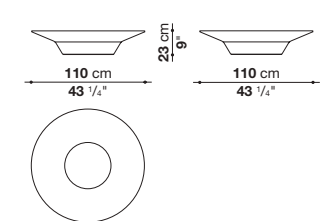

Top and frame Piano e struttura

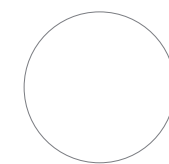

0101G
white Cristalplant Outdoor®
Cristalplant Outdoor® bianco

The colour and material shown are an indication. Image not in scale.
La tonalità del colore e del materiale è indicativa. Immagine non in scala.

Titikaka

Naoto Fukasawa • 2009

Inspiration • 250



The waters of Lake Titikaka dictate the shape (and name) of the bench by Fukasawa. This stretch of water lies between Bolivia and Perù, a lake 204 km long and 65 km wide that occupies around 8562 km². This very beautiful place caught the designer's attention, and he tried to capture the movement of the waves to "move" the bench into a new, wavy shape. Titikaka revolutionises the concept of a bench. The traditional typology of the outdoor bench is revamped with contemporary language. It's an impressive piece that resembles a sculpture. Made of teakwood slats that cover the structure to the ground on both front and back, positioned horizontally on the aluminium structure in an original wave-like arrangement to create curves that are both pleasant and ergonomically functional.

Le acque del lago Titikaka dettano la forma (e il nome) della panca firmata Fukasawa. Tra Bolivia e Perù, il bacino di 204 km di lunghezza per 65 di larghezza occupa un'area di 8.562 km². Il luogo di grande suggestione ha colpito la fantasia del designer, che ha cercato di catturare il movimento delle onde per "muovere" la panca dall'inedito andamento ondulatorio. Titikaka rivoluziona il concetto di panchina. Ripropone la tradizionale tipologia della panca per esterni con linguaggio contemporaneo e si impone per la sua presenza scultorea. È realizzata in listelli di teak che scendono a terra su entrambi i fronti e si distribuiscono intorno alla struttura in alluminio con un originale andamento ondulatorio creando curve insieme plastiche e funzionali all'ergonomia della seduta.

Frame	aluminium and solid wood
-------	--------------------------

Ferrules	plastic material
----------	------------------

Struttura	alluminio e legno massello
-----------	----------------------------

Puntali	materiale plastico
---------	--------------------

Bench Panca

TK

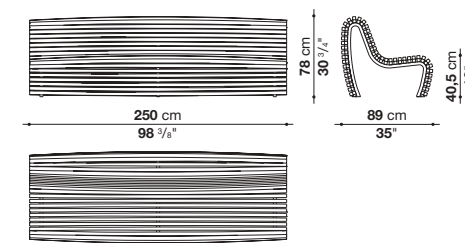

Frame Struttura

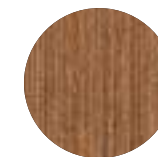

0440T
natural teakwood
teak naturale

The colour and material shown are an indication. Image not in scale.
La tonalità del colore e del materiale è indicativa. Immagine non in scala.

Tobi-Ishi Outdoor

Edward Barber and Jay Osgerby • 2017
Inspiration • 218



After the debut in the home collection, Edward Barber and Jay Osgerby design Tobi-Ishi Outdoor, the outdoor version of the iconic round dining table and of the low table clearly inspired by Zen. The design duo are great enthusiasts of Japanese art and culture, and the name and inspiration come from the smooth stones “tobi-ishi” used as ornaments in traditional Zen gardens. The overhang of the table and the vertical trapezoidal bases set at right angles generate an essential sculptural figure that appears to change shape depending on the point of observation. Exclusively made of cement, Tobi-Ishi Outdoor comes in two colour variants, grey and anthracite.

Dopo il debutto nella collezione casa, Edward Barber e Jay Osgerby propongono Tobi-Ishi Outdoor, la versione da esterno dell'iconico tavolo da pranzo rotondo e del tavolo basso con esplicite ispirazioni zen. I due designer sono grandi estimatori dell'arte e della cultura giapponese ed il nome e l'ispirazione è un riferimento alle pietre levigate “tobi-ishi” usate con funzione ornamentale nei tradizionali giardini zen. Lo sbalzo del piano e le basi trapezoidali verticali poste ortogonalmente tra loro generano una figura scultorea ed essenziale, che varia costantemente la propria immagine secondo il punto di osservazione. Unica la finitura del tavolo e del tavolo basso realizzati in cemento in due diverse varianti di colore, grigio ed antracite.

Top and legs	cement (Ultra High Performance Concrete)
Coupling plate	galvanized sheet
Feet	stainless steel
Ferrules	thermoplastic material

Piano e gambe	cemento (Ultra High Performance Concrete)
Piastra di aggancio	lamiera zincata
Piedini	acciaio inox
Puntali	materiale termoplastico

Tavolo Table

OT162

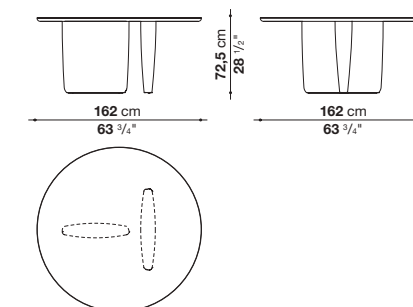

Low table Tavolo basso

OT146

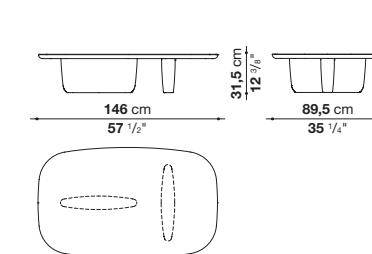

Top and legs Piano e gambe



0237G
grey cement
cemento grigio

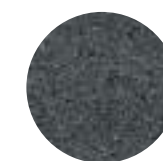

0149A
anthracite cement
cemento antracite

The colours and materials shown are an indication. Images not in scale.
La tonalità dei colori e dei materiali è indicativa. Immagini non in scala.

Tramae

unPIZZO • 2020

Inspiration • 236



unPIZZO, a design studio and textile handicrafts laboratory specialized in interlacing for furnishing, continues its research on the revival of ancient craft techniques with Tramae, a brand new ottoman for B&B Italia. Available in three dimensions, this small object full of character stands out for its hexagonal shape, which is rounded until the edges are no longer visible. The surface shows a singular dynamic mix of materials and colors that come to life through an exclusive weave that reinterprets the tradition of wicker basket making in a contemporary key. At the end of its lifespan, Tramae can be dismantled completely so that each component can be separated and disposed of in the best way for each material.

unPIZZO, studio di progettazione e artigianato tessile specializzato nell'intreccio per l'arredamento, prosegue la sua ricerca sul recupero di antiche tecniche artigianali con Tramae, un nuovissimo pouf per B&B Italia. Realizzato in tre dimensioni, questo piccolo oggetto pieno di carattere si contraddistingue per la forma esagonale che si arrotonda fino a perdere gli spigoli. La superficie presenta un singolare dinamismo di materiali e colori che prendono vita grazie ad un intreccio esclusivo che rilegge in chiave contemporanea la tradizione della lavorazione dei cesti in vimini. Tramae è completamente disassemblabile. Alla fine del suo ciclo di vita ogni singolo elemento che lo compone si potrà separare e smaltire seguendo il percorso più adatto a ogni materiale.

Frame	polyethylene
Upholstery	shaped polyurethane, cover in water repellent polyester fibre
Interlacing	polypropylene fibre braid
Cover	fabric in limited categories
Waterproof cover cloth	PES fabric coated on one side in PU

Struttura	polietilene
Imbottitura	poliuretano sagomato, fodera in fibra di poliestere con trattamento idrorepellente
Intreccio	treccia in fibra di polipropilene
Rivestimento	tessuto in categorie limitate
Telo di copertura impermeabile	tessuto PES monospalmato su un lato PU

Ottomans

Pouf

TRM47P

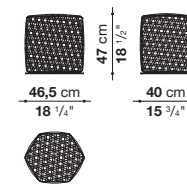

TRM60P

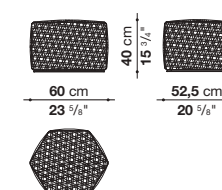

TRM90P

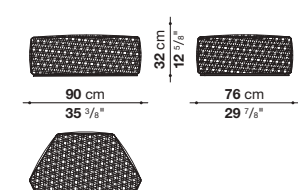

Interlacing

Intreccio

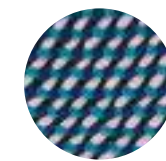

0843B
night blue polypropylene
polipropilene blu notte

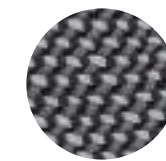

0296G
dark grey polypropylene
polipropilene grigio scuro

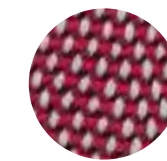

0729B
bordeaux polypropylene
polipropilene bordeaux

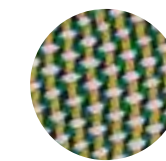

0417V
green polypropylene
polipropilene verde

The colours and materials shown are an indication. Images not in scale.
La tonalità dei colori e dei materiali è indicativa. Immagini non in scala.

Twist
B&B Italia CR&S · 2018
Inspiration • 266



Carpets	braided ropes with dyed Olyna FLYER® fibre
Composition	100% polyolefin

Tappeto	corde intrecciate con fibra tinta Olyna FLYER®
Composizione	100% poliolefine

Carpets
Tappeti

TW201

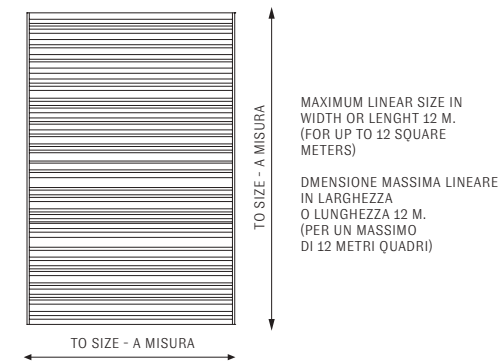

TW200

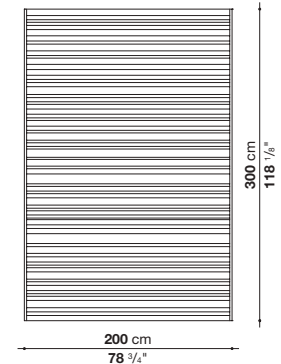

TW250

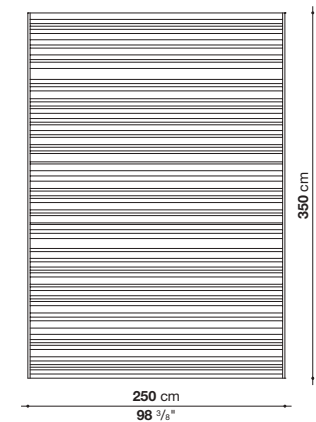

TW300

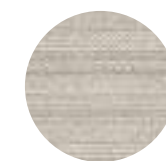
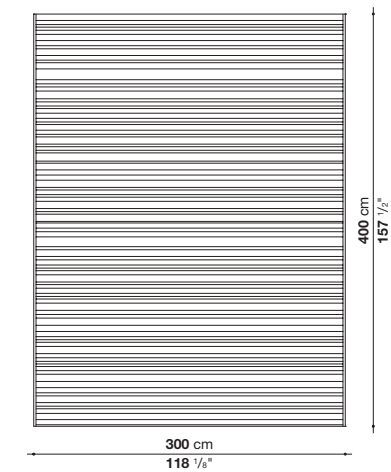

0239C
rope polyolefin
poliolefine corda

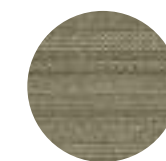

0402V
green polyolefin
poliolefine verde

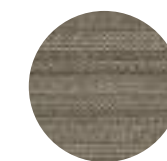

0292T
tortora polyolefin
poliolefine tortora

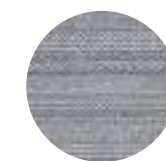

0358G
grey polyolefin
poliolefine grigio

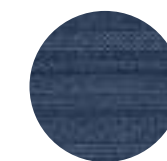

0832B
blue polyolefin
poliolefine blu



0318A
anthracite polyolefin
poliolefine antracite

The colours and materials shown are an indication. Images not in scale.
La tonalità dei colori e dei materiali è indicativa. Immagini non in scala.

White Collection
Marcel Wanders • 2008
Inspiration • 254



Frame enamelled ceramic

Struttura ceramica smaltata

Vases

Vasi

AB20046B

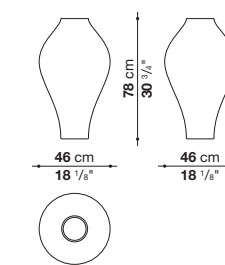

AB20047B

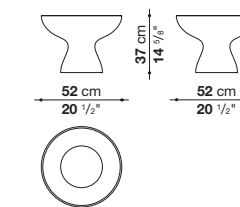

Stool
Sgabello

AB20048B

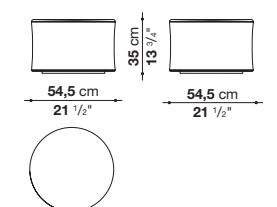

Frame
Struttura

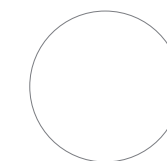

white
bianco

Fabrics Tessuti



Agate 100

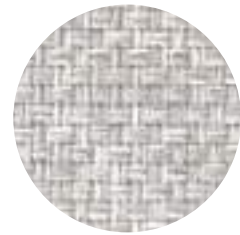

Agate 251

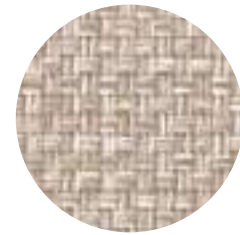

Agate 207

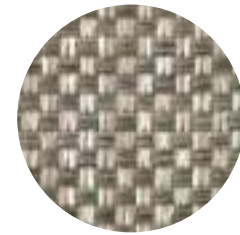

Agate 287

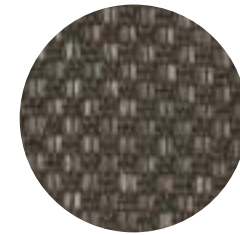

Agate 153

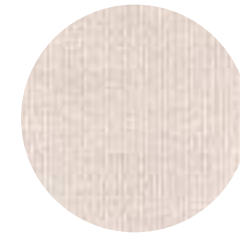

Aliseo 102

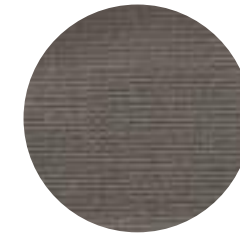

Aliseo 255

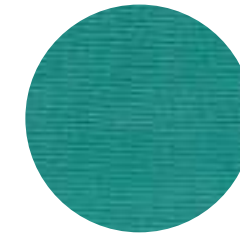

Aliseo 403

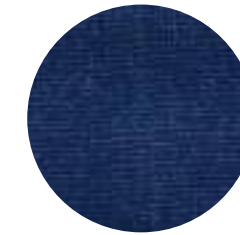

Aliseo 800

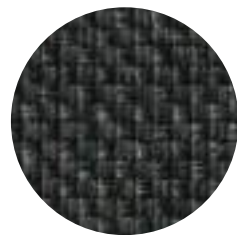

Agate 350

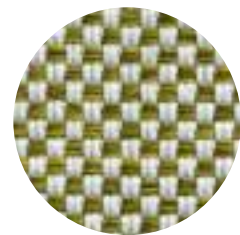

Agate 410

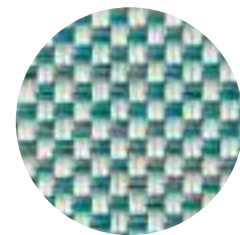

Agate 810

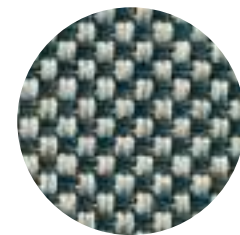

Agate 851

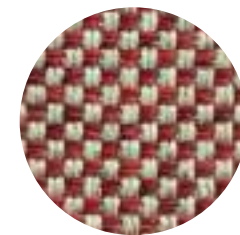

Agate 751



Bali 100

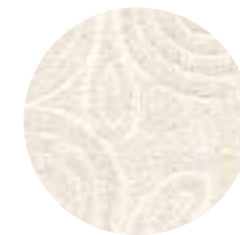

Bali fiorato 100

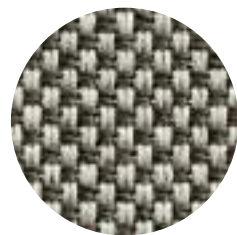

Agate 257

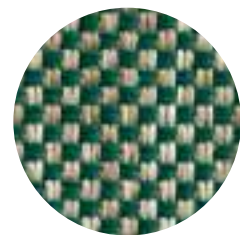

Agate 400

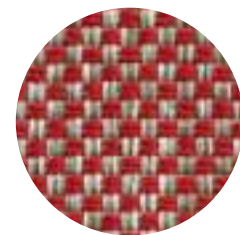

Agate 700

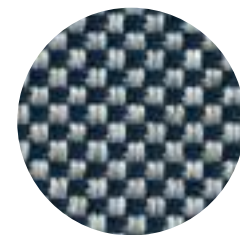

Agate 800



Elide 100

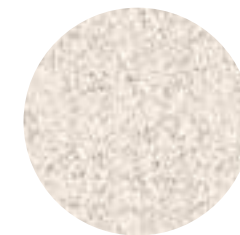

Elide 102

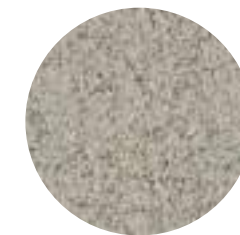

Elide 280

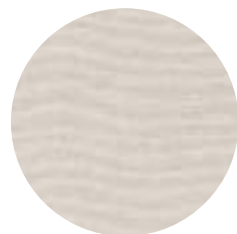

Alceo 100

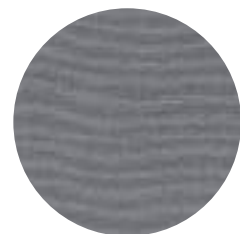

Alceo 255

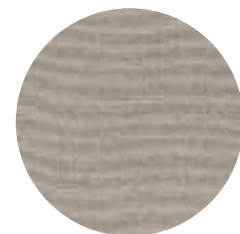

Alceo 258

Fabrics Tessuti



Elisir 207



Elisir 110



Elisir 115

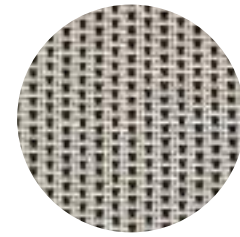

Elisir 120

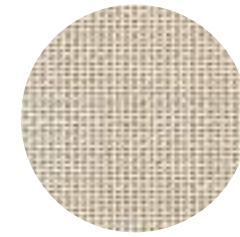

Elisir 207

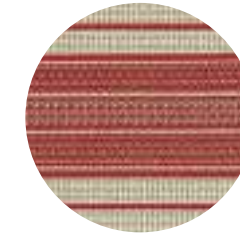

Elisir 710

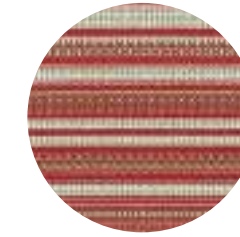

Elisir 715

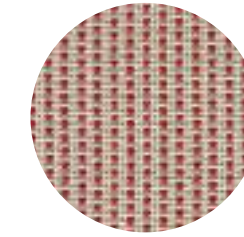

Elisir 720

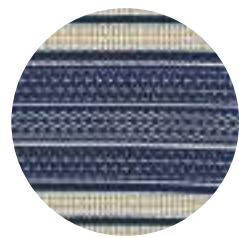

Elisir 810

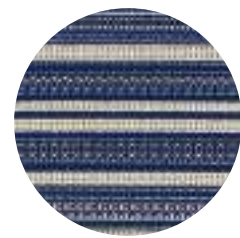

Elisir 815

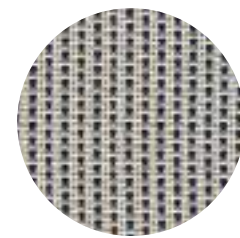

Elisir 820

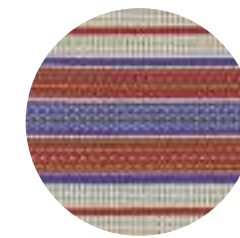

Elisir 310

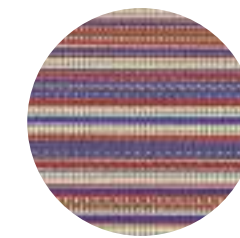

Elisir 315

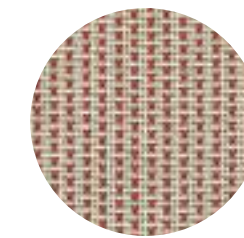

Elisir 320

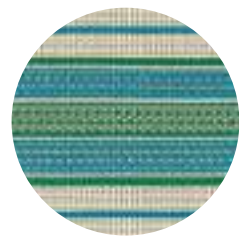

Elisir 410

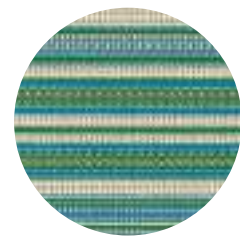

Elisir 415

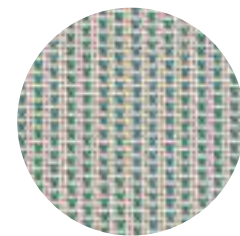

Elisir 420

Fabrics Tessuti



Ermitage 101

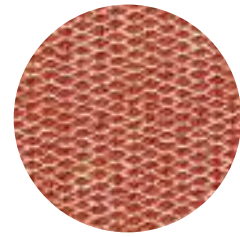

Ermitage 775

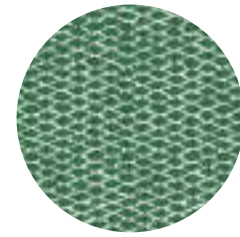

Ermitage 400

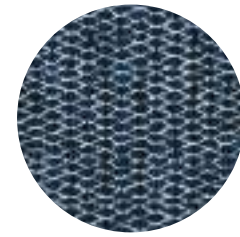

Ermitage 840

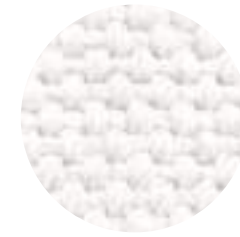

Lesia 101

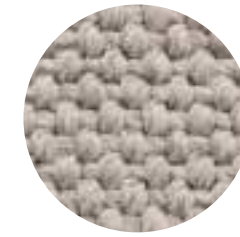

Lesia 207



Lesia 280

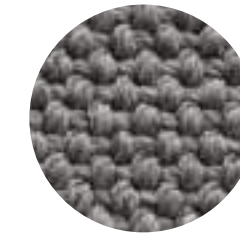

Lesia 251



Lesia 255



Leila 102



Leila 203

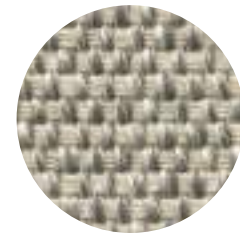

Leila 207

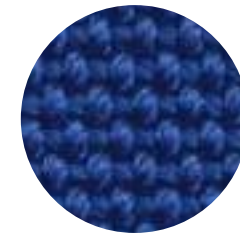

Lesia 877



Lesia 830

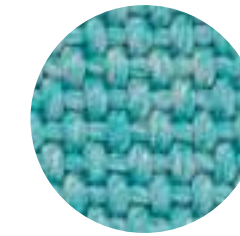

Lesia 820



Leila 280

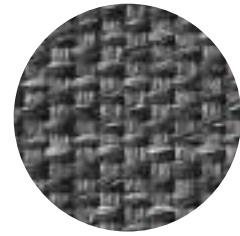

Leila 251



Leila 800

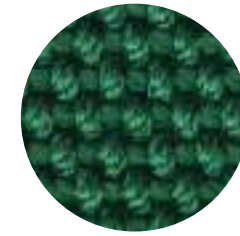

Lesia 400

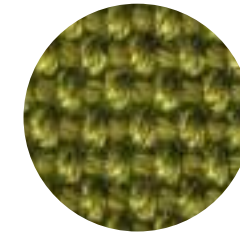

Lesia 407



Lesia 305

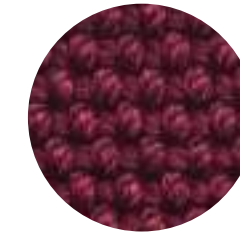

Lesia 750

Fabrics Tessuti

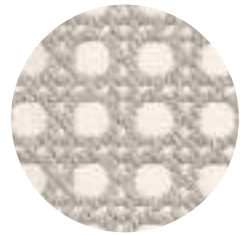

Linaria 207

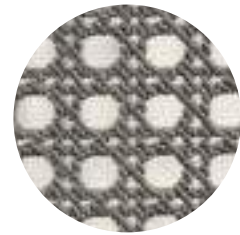

Linaria 251

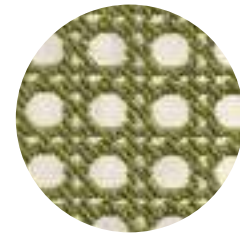

Linaria 407

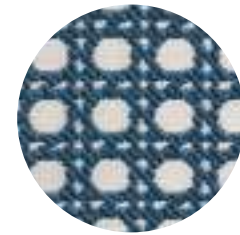

Linaria 830

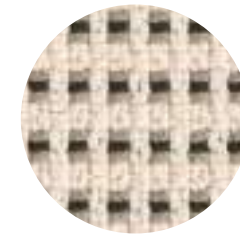

Lamone 275

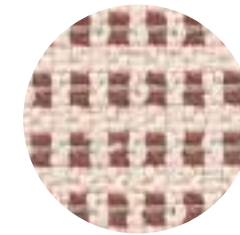

Lamone 385

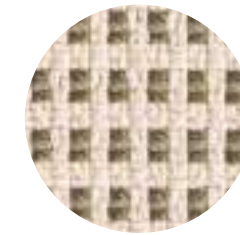

Lamone 425

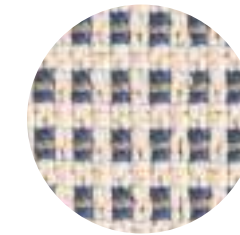

Lamone 895



Lipari 100



Lipari 207



Lipari 911



Lipari 280



Lipari 255



Lilia 100

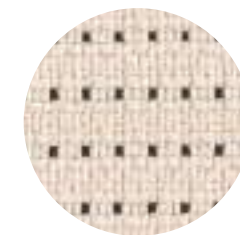

Lilia 111

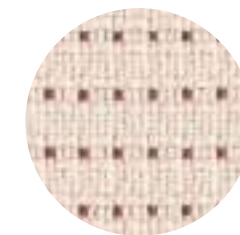

Lilia 311

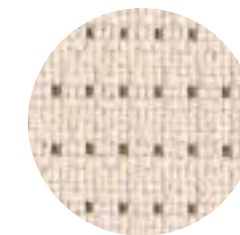

Lilia 411



Lilia 811



Lipari 407



Lipari 830

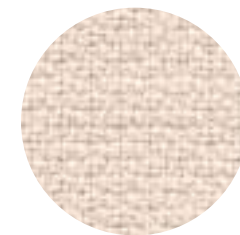

Lola 100



Liri 207



Liri 251



Liri 407



Liri 830

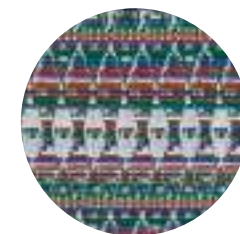

Salinas 715

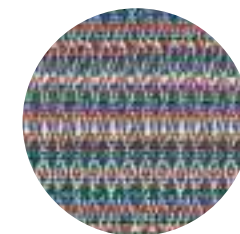

Salinas 735



Samos 877



Samos 450



Samos 750

Fabrics Tessuti

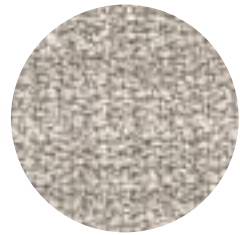

Saturno 151

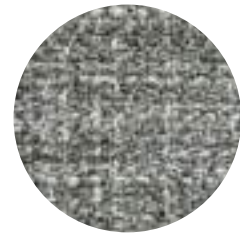

Saturno 258

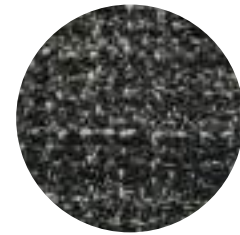

Saturno 377

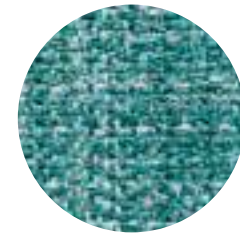

Saturno 403



Saturno 800



Solano 210



Solano 215



Solano 410



Solano 415



Solano 810



Solano 815

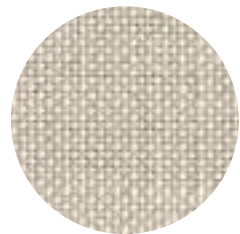

Scirocco 207

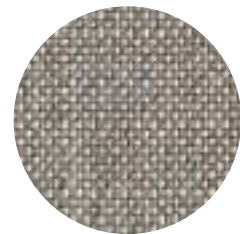

Scirocco 280

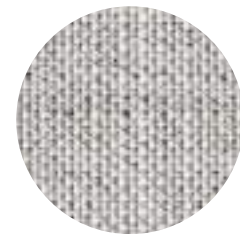

Scirocco 253

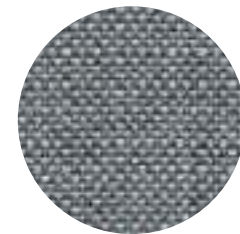

Scirocco 258

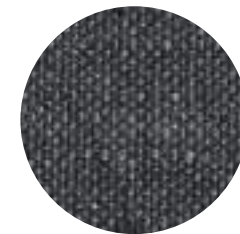

Scirocco 153

Dedicated fabrics Tessuti dedicati

Only for Husk Outdoor
Solo per Husk Outdoor



Eleo 100



Eleo 200

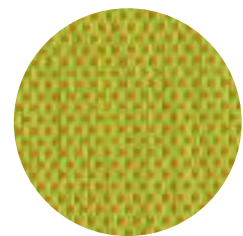

Eleo 450

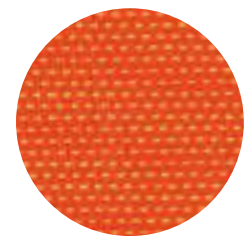

Eleo 570

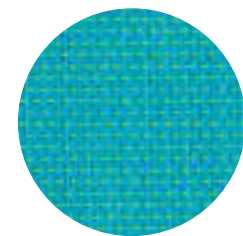

Eleo 810

Only for Mirto Outdoor
Solo per Mirto Outdoor

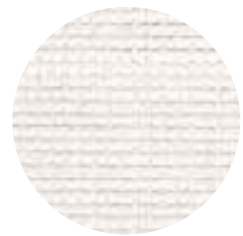

Stige 102

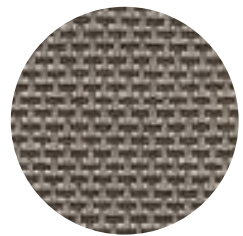

Stige 280

Only for Mirto Outdoor (MI59N)
Solo per Mirto Outdoor (MI59N)

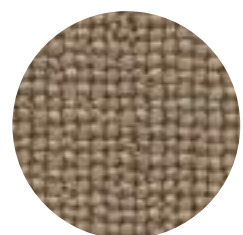

Laguna 102

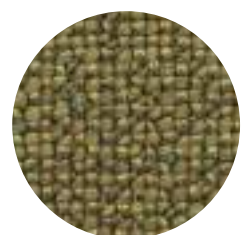

Lamar 401



Lamar 760

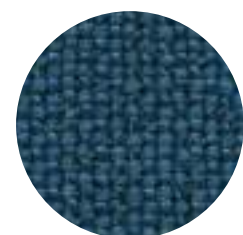

Lamar 890

Dedicated fabrics Tessuti dedicati

Only for Pablo Outdoor
Solo per Pablo Outdoor

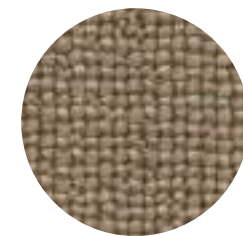

Laguna 102

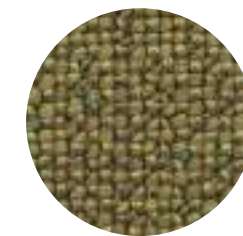

Lamar 401

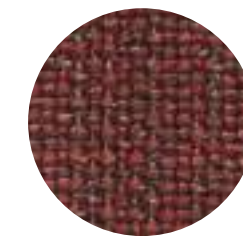

Lamar 760

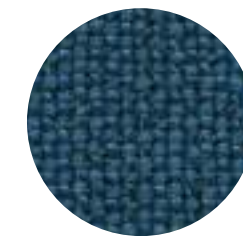

Lamar 890

Only for Oh, it rains!
Solo per Oh, it rains!



Silvi 102

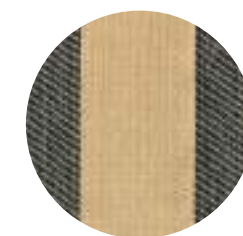

Skiathos 153



Spargi 153

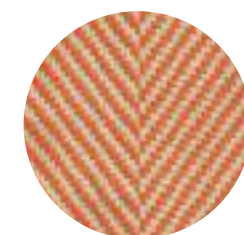

Spargi 570

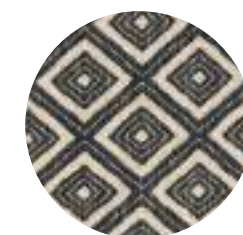

Symi 153



Symi 570

Contacts

Contatti

B&B ITALIA SPA
22060 Novedrate (CO) Italy
Strada Provinciale 32
T. + 39 031 795 111
F. + 39 031 791 592

info.bebitalia.com
www.bebitalia.com
www.maxalto.com

INFO
Italia
numero verde 800 018 370
USA
toll free number 800 872 1697

All other countries
T. + 39 031 795 213

B&B ITALIA STORES

Europe

D-Studio Milano
Via Durini 14
20122 Milano, Italy
T. + 39 02 764441
store.milano@d-studio.com

D-Studio Copenhagen
Kuglegårdsvej 13-17
1434 Copenhagen, Denmark
T. + 45 7872 8200
info.cph@d-studio.com

B&B Italia London
250 Brompton Road
South Kensington
SW3 2AS London, U.K.
T. + 44 20 7591 8111
info.bromptonroad@bebitalia.com

B&B Italia Paris
35 Rue du Bac
75007 Paris, France
T. + 33 1 55 35 14 35
info@bebitalia.fr

B&B Italia Saint-Tropez
Avenue Maréchal Foch
Quartier Saint Roch
83990 Saint-Tropez, France
T. + 33 4 94 45 77 20
contact@bebsttropez.fr

B&B Italia Lyon
22 Rue Auguste Comte
69002 Lyon, France
T. + 33 9 86 56 21 53
bebitalia@maisonhomedesign.fr

B&B Italia München
Maximiliansplatz 21
80333 München, Germany
T. + 49 89 4613680
store.muenchen@bebitalia.com

B&B Italia St. Petersburg
Sredniy Prospekt V.o. 83/2
199106 St. Petersburg,
Russian Federation
T. + 7 812 617 43 80
rossi.info@gmail.com

B&B Italia Athens
358 Kifisias Ave 15233
152 33 Chalandri - Athens, Greece
T. + 30 21 0684 7720
info@deloudis.gr

B&B Italia Cyprus
41-49 Ag. Nicolaou Street
2408 Engomi - Nicosia, Cyprus
T. + 357 7777 15 11
info@ergohomegroup.com

Americas

B&B Italia New York
150 East 58th Street
NY 10155 New York, U.S.A.
T. + 1 212 758 4046
info.usa@bebitalia.com

B&B Italia Madison Avenue
135 Madison Avenue
NY 10016 New York, U.S.A.
T. + 1 212 889 9606
info.usa@bebitalia.com

B&B Italia Washington DC
3320 M Street North West
DC 20007 Washington, U.S.A.
T. + 1 202 337 7700
info.usa@bebitalia.com

B&B Italia Los Angeles
8801 Beverly Boulevard
CA 90048 Los Angeles, U.S.A.
T. + 1 310 278 3191
info@divafurniture.com

B&B Italia Chicago
314 West Superior Street
IL 60654 Chicago, U.S.A.
T. + 1 312 335 3855
info@wpachicago.com

B&B Italia Miami
4141 NE 2nd Avenue Suite 115/114
FL 33137 Miami, U.S.A.
T. + 1 786 310 7255
info.usa@bebitalia.com

B&B Italia Dallas
1707 Oak Lawn Avenue
TX 75207 Dallas, U.S.A.
T. + 1 214 389 9513
info.usa@bebitalia.com

B&B Italia San Francisco
2211 Alameda Street
CA 94103 San Francisco, U.S.A.
T. + 1 415 565 7200
sales@bb-sf.com

B&B Italia Seattle
1300 Western Avenue
WA 98101 Seattle, U.S.A.
T. + 1 206 287 9992
seattle@divafurniture.com

B&B Italia Sun Valley
110 Lindsay Circle
ID 83340 Ketchum, U.S.A.
T. + 1 208 928 6379
info@arsunvalley.com

B&B Italia São Paulo
Avenida Brasil 1653 Jardim America
01431-001 São Paulo SP, Brazil
T. + 55 11 3368 6033
contato@casualmoveis.com.br

B&B Italia Belo Horizonte
Rua Andaluzita 125 Carmo Sion
30310-030 Belo Horizonte MG, Brazil
T. + 55 31 3281 4882
contato@casualmoveis.com.br

Asia

B&B Italia Tokyo
1, 3F Aoyama Om- Square 2-5-8
Kita Aoyama,
107-0061 Minato-ku - Tokyo, Japan
T. + 81 03 3478 3837
info@bebitalia.co.jp

B&B Italia Hong Kong
31/F 1st floor China Online Center
333 Lockhart Road Wan Chai
Hong Kong, China
T. + 852 2295 6263
bebitalia@colourliving.com

B&B Italia Beijing
No. 5-1-03 1st floor International Hall
Easyhome at North 4th Ring Road
Chaoyang District
100101 Beijing, China
T. + 86 010 8464 8161
beb@designspace.com.cn

B&B Italia Dalian
Liju Household 1st floor
72 Renmin East Road
Zhongshan District
116000 Dalian City, China
T. + 86 411 3998 5686
glory@dalian-glory.com

B&B Italia Shanghai
Unit L1 W10 No. 168 Hubin Road
Huangpu District
200021 Shanghai, China
T. + 86 021 6330 0606
info@arealiving.cn

B&B Italia Nanjing
No. 168 Jiangdongzhong Road
Jianye District
210019 Nanjing, China
T. + 86 25 6819 7311
info@yonglong-furniture.com

B&B Italia Chengdu
Unit 1071-1072 1st floor
No. 3 Fusen Mall
No. 18 Shenghe 2nd Road
Gaoxin District
610014 Chengdu, China
T. + 86 177 8069 8361
info@tinyhome.cn

B&B Italia Foshan
Louvre Mall 5th-6th floor
Lecong Section of National
Highway No. 325
Shunde District
528315 Foshan, China
T. + 86 400 1881 222
louvre@louvre-casa.com

B&B Italia Wenzhou
1st floor Building 1 Wancui Plaza
121 Sanyou Road
Lucheng District
325000 Wenzhou, China
T. + 86 577 8988 2225
marketing@womehome.com

B&B Italia Guangzhou
Poly Finance Tal To Wun 4rd floor
Huangpu Avenue No. 666
Tianhe District
510620 Guangzhou, China
T. + 86 400 188 1222
louvre@louvre-casa.com

B&B Italia Hangzhou
D01-A-F1-11/12 1st floor DerLook
No.18 West Lake Avenue
Binjiang District
310000 Hangzhou, China
T. + 86 571 8698 5388
marketing@fordcasa.com

B&B Italia Ningbo
A-28 1st floor DerLook
No. 315 Ningchuan Road
Yinzhou District
315000 Ningbo, China
T. + 86 574 8773 1580
13605740532@qq.com

B&B Italia Shenzhen
S218-S220 Block 10
Upperhills Shopping Mall
No. 5001 Huanggang Road
Wah Fu Street Lotus Merlin Community
Futian District
518000 Shenzhen, China
T. + 86 755 8899 9995
michellezhang@domustiandi.com

B&B Italia Wuhan
Shop L528 5th floor Heartland 66
No. 668 Jinghan Street
Qiaokou District
430000 Wuhan, China
T. + 86 131 7968 0909
344395659@qq.com

B&B Italia Zhengzhou
L1-119-120 LG1-B112 Yongwei
Muse Park Shopping Mall
No. 6 Shangwu Dongwu Street
Jinshui District
450018 Zhengzhou, China
T. + 86 371 586 66655
jessica@uandmilfe.com

B&B Italia Kaohsiung
65-67 Minquan 1st Road
Lingya District
80251 Kaohsiung City, Taiwan
T. + 886 7 332 7676
service@bonmaison.co

B&B Italia Taipei
2F No. 95 Sec. 2
Dunhua South Road
Da'an District
10682 Taipei City, Taiwan
T. + 886 2 2755 5855
service@bonmaison.co

B&B Italia Taichung
No. 211 Chaofu Road
Xitun District
40757 Taichung City, Taiwan
T. + 886 4 2258 5632
service@bonmaison.co

B&B Italia Seoul
777 Samseong-ro
Cheongdam-dong
Gangnam-gu - Seoul, South Korea
T. + 82 2 3447 6000
infini@infini.co.kr

B&B Italia Busan
454 Jwadongsunhwan-ro
Haeundae-gu
Busan, South Korea
T. + 82 5 1731 3470
infini@infini.co.kr

B&B Italia Bangkok
523 Maha Phruttharam Road
10500 Bangkok, Thailand
T. + 66 2 237 6999
badipol.ch@yipjacks.com

B&B Italia Ho Chi Minh City
22-36 Nguyen Hue Boulevard
& 57-69F Dong Khoi Street
Ben Nghe Ward District 1
Ho Chi Minh City, Vietnam
T. + 84 286 684 0333
bebitalia@eurasia-concept.com

B&B Italia Manila
Twenty-Four Seven McKinley Building
24th Street Corner 7th Avenue
at McKinley Parkway
1634 Bonifacio Global City, Philippines
T. + 63 2 8705 9999
bebitaliamanila@focusglobalinc.com

B&B Italia Ahmedabad
FF-1 Circle Opp. Panchvati Auto
100 feet Road Satellite
Sarkhej Gandhinagar Road
380015 Ahmedabad, India
T. + 91 71 6743 2900
trentteso@gmail.com

B&B Italia New Delhi
349 1st floor Mehrauli-Gurgaon Road
next to Sultanpur Metro Station,
110030 New Delhi, India
T. + 91 99 9969 3093
beb@scalahome.in

Middle East / Africa

B&B Italia Dubai
Jumeirah 3 beside Offshore
Sailing Club - Jumeirah St
1038 Dubai, U.A.E.
T. + 971 4 346 6932
baituti@baituti.com

B&B Italia Beirut
Martyr Square, An Nahar Building
Downtown Beirut, Lebanon
T. + 961 1 971 444
bebitalia@leccercle.me

B&B Italia Tel Aviv
HaTa'arucha Street 3
6350903 Tel Aviv-Yafo, Israel
T. + 972 3 744 9935
oshrat@theboxfurniture.co.il

Credits Crediti

Photography

Tommaso Sartori
Fabrizio Bergamo
Salva Lopez

Styling

Studio Salaris
Patrizia Cantarella
pc studio
Monica Montemartini
Simona Silenzi Studio
Francesca Santambrogio

Printing

Nava Press

Copyright

CR&S B&B Italia
March 2022

Thanks to

Atmosphere d'Ailleurs, As'art, Ay Illuminate,
Barbera/Madelli, Charlotte Kidger, Claudio
Pulicati, Compasso Gallery, concrete sculpture
by Marco Olgio, Danese, Francesco Perego,
Gaetano di Gregorio, Galleria Rossana Orlandi,
Giacomelli giardini, Ilaria Bianchi, Industreal,
Kommod Luca Leandri- Galleria Amuralab,
Lola Montes Schnabel, Officine Saffi, Oluce,
Pallodi, Pinetti, Pulpo, Scandola Marmi, Serax,
Sfera, Sergio Maria Calatroni, Terrecotte Poggi
Ugo, Vetrofuso Vicara, Viv Lee, 101 Copenhagen

All lighting courtesy

Flos Outdoor

Descriptions and pictures of products included in this catalogue have an indicative value only and are not binding for products' use. B&B Italia reserves the right to modify their products without prior notification. For further technical information of the products, please contact the authorised dealer closest to you (see www.bebitalia.com).

La descrizione e le immagini dei prodotti del presente catalogo sono puramente indicative e non possono essere considerate vincolati ai fini del loro utilizzo. B&B Italia si riserva di apportare ai prodotti le modifiche che ritiene più opportune, in qualsiasi momento e senza preavviso. Per ulteriori informazioni sulle caratteristiche tecniche dei prodotti, invitiamo a consultare il sito www.bebitalia.com dove troverete l'elenco dei rivenditori autorizzati a cui rivolgerci.